

FYBROC®
SERIES 5500

FIBERGLASS CONSTRUCTION
FOR CORROSIVE APPLICATIONS

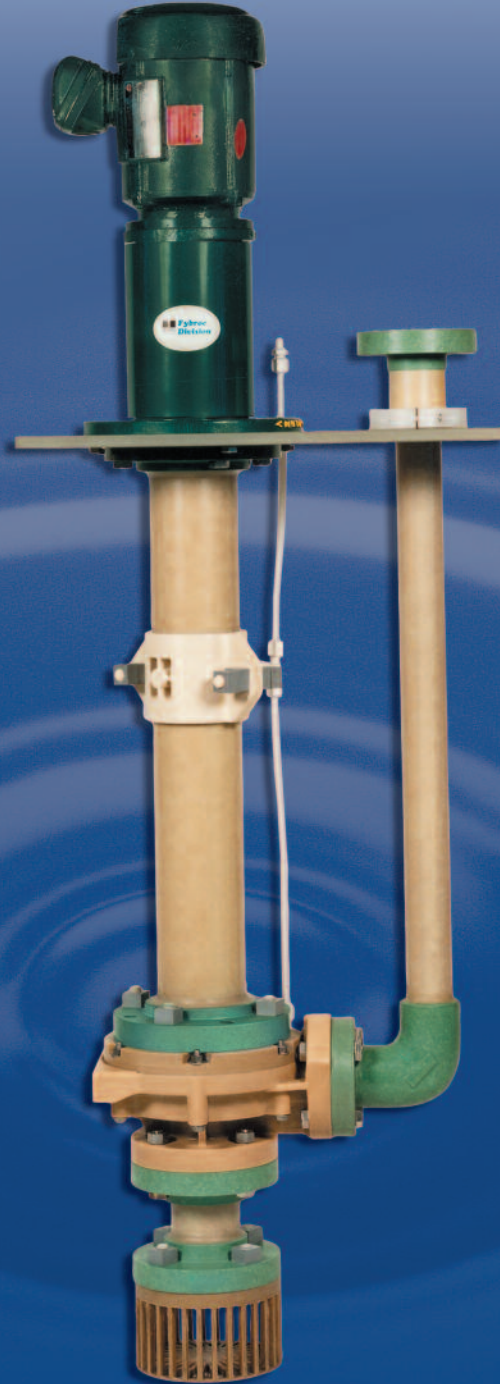

Fybroc® Vertical Fiberglass Sump Pumps

BULLETIN 55B1

FYBROC – THE LEADER IN CORROSION-RESISTANT FIBERGLASS PUMPING EQUIPMENT

Fybroc, the world's first and largest manufacturer of fiberglass reinforced centrifugal pumps, has led the way in the design and engineering of the industry's most technically advanced pumps for handling corrosives and other difficult liquids.

Fybroc continues to lead the pump industry through innovation, product improvement, and advanced technology. Each Fybroc product line is the culmination of years of experience in producing the highest quality corrosion-resistant pumps available.

FYBROC SERIES 5500

- Capacities to 5,000 GPM (1,140 m³/hr)
- Heads to 275 feet (85 m)
- Pump lengths to 30 ft (9.1 m)
- Nineteen sizes
- Custom built to match customer pit/sump requirements

The Series 5500 Vertical pump is the product of Fybroc's extensive engineering experience and knowledge of specialized production techniques. The result is a corrosion-resistant, structurally superior, highly dependable pump suitable for the most difficult sump applications.

Fybroc has given special attention to critical design details that ensure the ultimate in operating life, ease of maintenance, and dependability in a vertical sump pump. The innovative design of the Series 5500 pump makes it a perfect choice for handling tough applications such as chemical wastes of varying pH, plating wastes, circulation of spent pickling solutions, electrolytes or nickel plating baths, salt water or brine, scrubber/odor control, utility/coal pile runoff, demineralized/deionized water, marine applications (ie. dewatering and barges/cargo unloading), and hundreds of other difficult sump pump services.



Fybroc Series 5500 Vertical pump installation

MATERIALS OF CONSTRUCTION ARE AVAILABLE FOR A WIDE RANGE OF CORROSIVE LIQUIDS

Only Fybroc has the flexibility in materials selection to solve your difficult corrosive or abrasive pump problems.

- **VR-1**, vinyl ester resin: used for the vast majority of corrosive applications including most acids, caustics, brines, sea water, and wastewater.
- **VR-1 BPO-DMA**, vinyl ester resin with BPO-DMA cure system: used to accommodate applications for specific corrosion resistance to bleaches such as sodium hypochlorite (NaOCl) and hydrogen peroxide (H₂O₂).
- **VR-1A**, vinyl ester resin with abrasive resistant material: used for pumping liquids with low concentration highly abrasive fines such as fly ash, diatomaceous earth or titanium dioxide.
- **EY-2**, epoxy resin: offers outstanding chemical resistance for aggressive chemical/compounds, acids, and solvents. Ideal for high concentrations of sulfuric acid (up to 98%).

The pump shaft and exposed bolts and nuts are furnished in materials selected for the specific application; typical materials are 316SS, Alloy-20, Titanium, or Hastelloy-C. For further information on corrosion resistance to specific chemicals, please refer to the Fybroc website at www.mp-gps.com. Additional special materials are available upon request.

FDA COMPLIANCE

The Dow DERAKANE series epoxy vinyl ester resin utilized by Fybroc, when properly formulated and cured, will comply with the U.S. Food, Drug, and Cosmetic Act, as amended, and applicable FDA regulations (21 CFR 177.2420). These resins may be used as articles or components of articles intended for repeated use in contact with food, subject to certain limitations described in that regulation.

DESIGNED FOR OPTIMUM BEARING LIFE

Bearings are a critical component in any sump pump. Fybroc has focused on the design of bearings in the Series 5500 Vertical pump in order to optimize their performance, while

ensuring long life and trouble-free operation. Fybroc's unique design approach also incorporates a number of key features which greatly simplify maintenance.

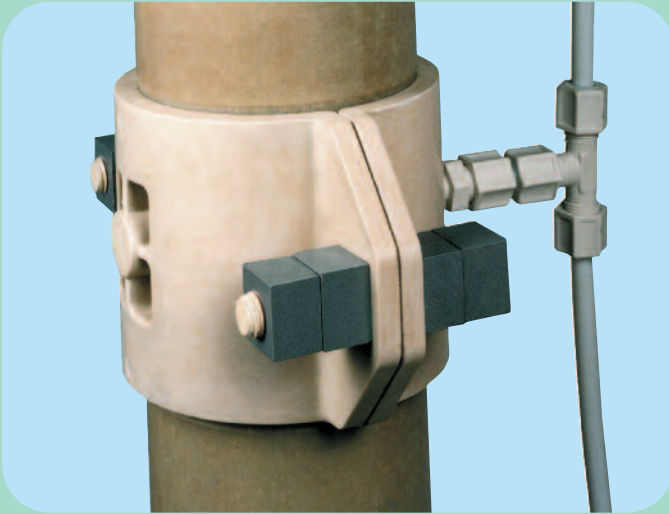

Fybroc's unique sleeve bearing is clamped to the column with fiberglass bolting

THRUST BEARING

Fybroc Series 5500 Vertical pumps utilize a grease-lubricated ball bearing designed to handle the axial thrust load generated by the pump impeller. This bearing, which is easily replaceable without removing the installed pump, permits the use of standard, "off-the-shelf" C-face motors.

SPLIT SLEEVE BEARINGS

One of the Series 5500 pump's most innovative features is its axially split sleeve bearings. These Teflon® and carbon-filled polyphenylene sulfide (PPS) bearings, which are held in place by an externally mounted split fiberglass bearing holder as shown in the photographs at left, can be replaced conveniently without dismantling the entire pump (including the shaft). The bearing holders are drilled to provide necessary flush liquid to the grooved bearings. Sleeve bearings are mounted at a maximum spacing of 30 inches (762 mm) to ensure that the pump operates well below its first critical speed.

LOWER SLEEVE BEARING

The pump sleeve bearing has received special attention since it carries the greatest amount of radial load in the pump. The Fybroc Series 5500 pump utilizes a Teflon® and carbon-filled PPS lower bearing that is grooved to ensure generous lubrication. This bearing, which is locked into position in the pump cover by a fiberglass key and a polypropylene snap ring, is longer than the upper bearings for increased surface area. The resulting lower unit loading substantially improves bearing life.

PUMP COLUMN

The Fybroc Series 5500 features a large diameter column which, because of its moment of inertia, stiffens the entire pump assembly and reduces deflection loads on the column bearings. Another aspect of the column's unique design is the location of the sleeve bearing holes in the column. They are positioned so that in the event of shaft wear, the column can be inverted end-for-end to allow the bearings to run on unworn surfaces of the existing shaft, thereby extending the useful life of the shaft and reducing costly downtime.

DUAL VOLUTE

Another important distinction of the Fybroc Series 5500 is the use of dual volute casings. Radial thrust from the pump impeller, which can highly load the lower bearing, is greatly reduced by this feature. Fybroc uses double volute casings in eleven of its larger pump sizes where, typically, radial thrust loads are higher. See chart on page 9, Casing Data Volute.

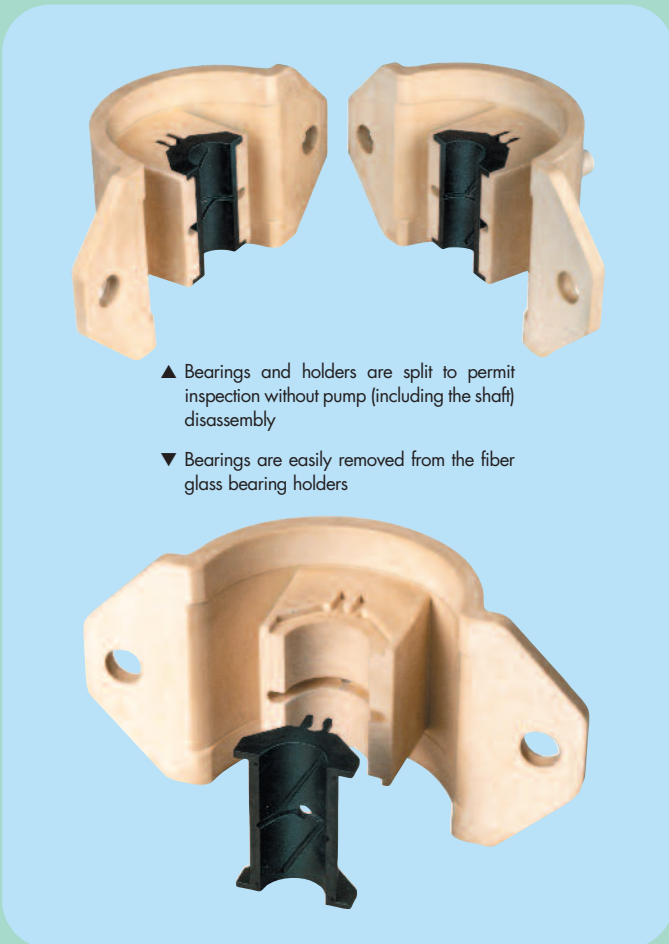

▲ Bearings and holders are split to permit inspection without pump (including the shaft) disassembly

▼ Bearings are easily removed from the fiberglass bearing holders

DESIGN FEATURES OF THE FYBROC SERIES 5500 VERTICAL PUMP

The Fybroc Series 5500 Vertical pump has been designed to provide exceptional structural integrity, excellent corrosion-resistance, and dependable service in the most

difficult chemical or waste sump environments. The unique features described on these pages provide the ultimate in operating life and ease of maintenance.

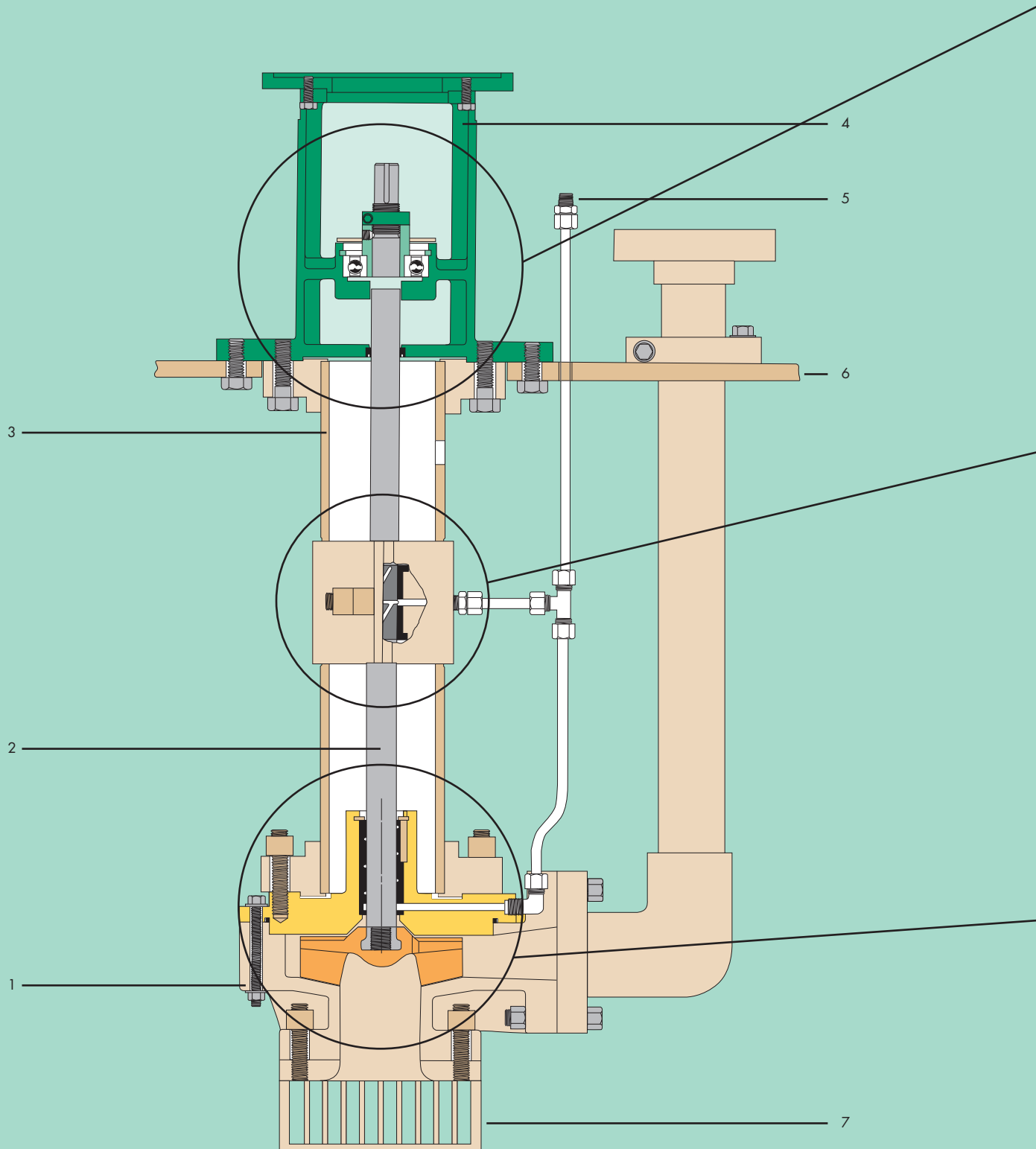

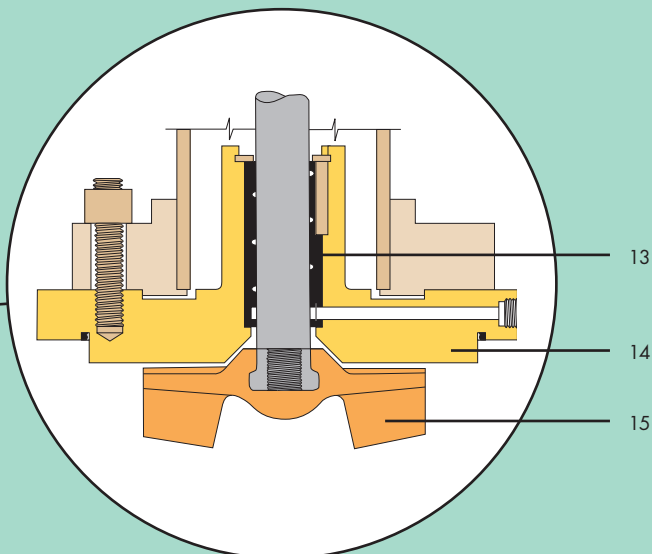
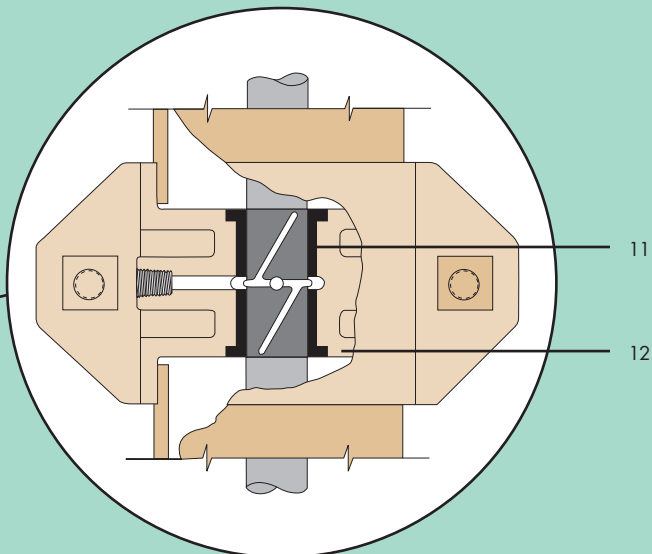
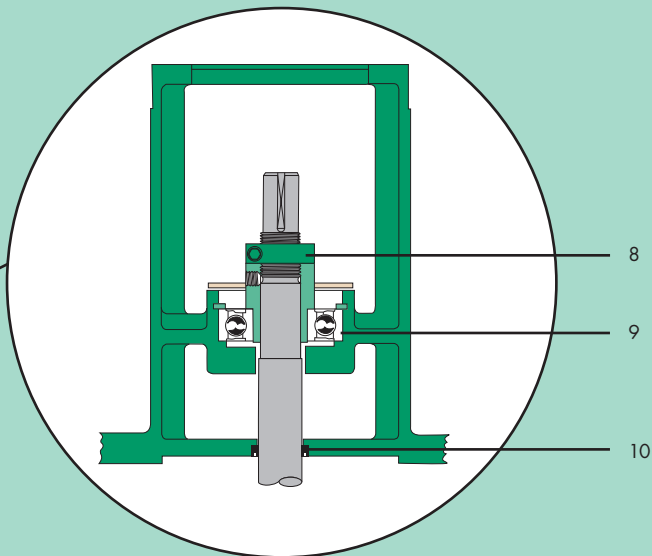

1. **FIBERGLASS CONSTRUCTION** for all wetted parts, except shaft and bolting, in either vinyl ester or epoxy resins provides tough corrosion resistance for a wide range of difficult liquids.
2. **PRECISION-GROUND SHAFT** and all wetted bolting are selected to suit specific applications and are typically 316SS, Alloy-20, Titanium or Hastelloy-C.
3. **LARGE DIAMETER COLUMN**, fitted with heavy duty Class 150 flanges on each end, stiffens the pump assembly to extend bearing life. The column can be inverted end-for-end thereby offsetting existing bearing ports and extending shaft life.
4. **HEAVY-DUTY BEARING PEDESTAL** is of cast iron construction to rigidly support the pump column, thrust bearing and motor, and is protected from external corrosion by a polyester thermosetting powder coating.
5. **SLEEVE BEARING FLUSH** lines are arranged to simplify field connection of external flush liquid. When the process liquid is free of solids, flush lines can be connected to the pump discharge for lubrication. In addition, short setting pumps can be configured with an internal cover flush to supply lubrication to the lower sleeve bearing.
6. **FIBERGLASS MOUNTING PLATE** is of heavy duty fiberglass and of appropriate thickness and size to support the pump and motor. Mounting plates are available in both standard and custom configurations.
7. **FIBERGLASS BASKET STRAINER**, attached to the casing by fiberglass studs and nuts, protects the pump casing and impeller against damage from trash or other debris.
8. **EXTERNAL IMPELLER ADJUSTMENT** allows field setting of impeller-to-casing operating clearance from above the mounting plate.
9. **THRUST BEARING** is easily replaceable and carries the entire axial thrust load from pump impeller, allowing use of flexible couplings and standard, "off-the-shelf" motors.
10. **VAPOR SEAL** protects thrust bearing from corrosive sump vapors.
11. **AXIALLY-SPLIT BEARINGS**, made of Teflon® and carbon-filled PPS, are grooved to ensure even lubricant dispersion and are easily replaceable while the pump (including the shaft) remains completely assembled.
12. **SPLIT BEARING HOLDERS** align the bearings with the pump column. Molded in fiberglass, the holders are drilled to supply flush to the bearings.
13. **REPLACEABLE LOWER PUMP SLEEVE BEARING**, extra-long to reduce unit surface loading, is grooved PPS like the upper sleeve bearings, and is secured in the cover by a key and snap ring.
14. **PUMP COVER** is drilled for flush liquid supply to the lower bearing. A fully-confined Viton O-ring (optional elastomers available) seals the cover to the casing.
15. **SEMI-OPEN IMPELLER** utilizes rear pump-out vanes and balance holes to reduce the load on the axial thrust bearing.

FYBROC SERIES 5500 – AVAILABLE OPTIONS

Many construction options are available with the Series 5500 in addition to the various materials combinations listed on page 2. The options shown here are those most frequently utilized; please contact the Fybroc factory or your local distributor for information on any desired special configurations.

REPLACEABLE SHAFT SLEEVES

Fybroc Series 5500 Vertical pumps can be furnished with replaceable shaft sleeves under the lower sleeve bearing. This feature allows replacement of the sleeve, rather than the entire shaft, in the event of wear due to loss of flush liquid.

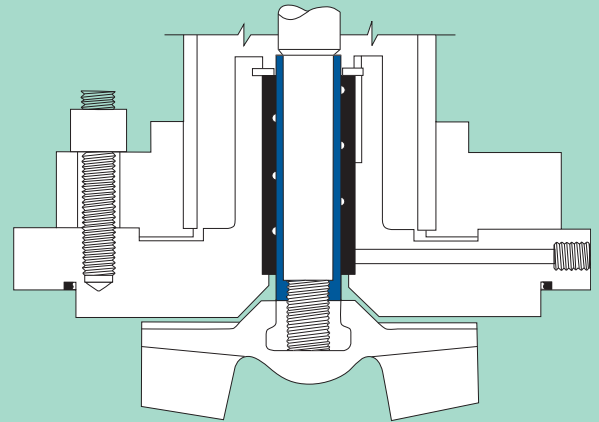

Optional replaceable metal shaft sleeve is shown in blue

MOUNTING PLATES

Standard mounting plate dimensions are listed on page 10. Mounting plates with special dimensions, such as to match an existing pump, are readily available. Fiberglass pit covers, designed to mount one or more pumps, plus provision for level controls, are also available.

TAILPIPES

Tailpipes are a frequently utilized option which serve to increase the effective length of the pump, with a minimum of additional cost. Typically used in a demand-type sump, level controls are arranged to start the pump when the liquid covers the top of the pump casing, and to stop the pump when the liquid nears the bottom of the tailpipe. Minimum submergence requirements are shown at bottom left.

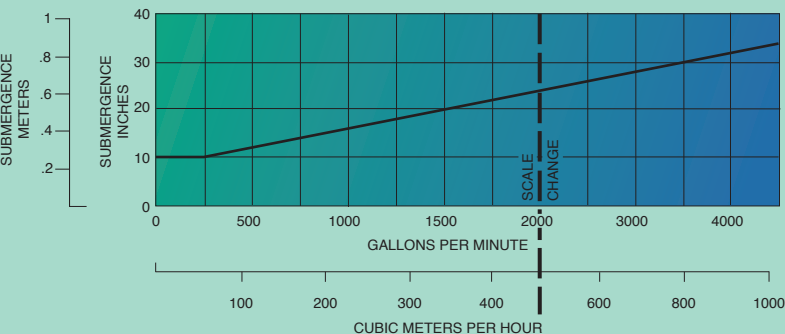

Pump or tailpipe submergence requirements

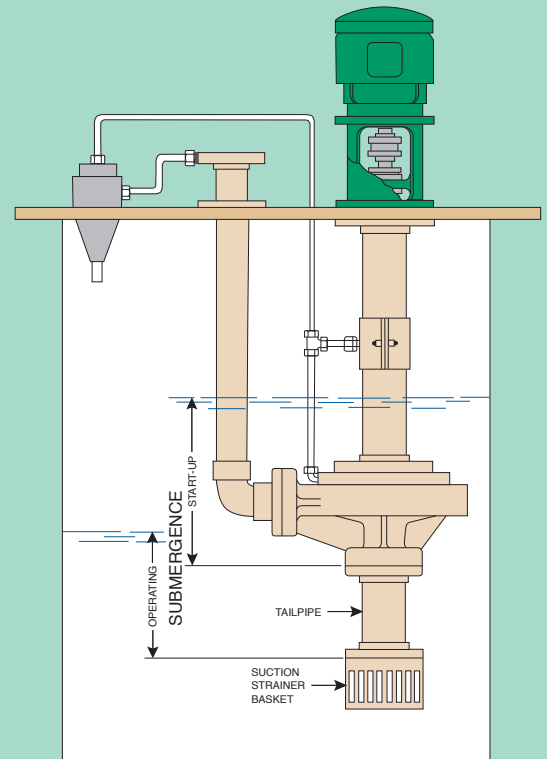

Cyclone separator for bearing flush and tailpipe options are shown mounted on a pump

BEARING LUBRICATION METHODS

External flush

Line shaft bearings/lower sleeve bearing should be lubricated with a continuous source of clean liquid at a rate of 1/4 to 1/2 GPM (0.95 to 1.9 l/min) per bearing at 10 - 20 PSI (69.0 to 137.9 KPa). A connection for external flush leading to the flush tubing to all bearings is provided above the mounting plate.

Internal cover flush

For the lower sleeve bearing, pump cover can be drilled for flush liquid supply. Process fluid must be clean and free of solids. This applies for short setting pumps only, maximum pump length of 36 inches (914.4 mm).

Bypass flush

For the line shaft bearings/lower sleeve bearings, flush liquid can be supplied from the pump discharge if the discharge pressure is sufficient. The flush tubing would be connected to the discharge pipe to provide the lubricating and cooling. Process fluid must be clean and free of solids.

Optional, additional bearing lubrication methods (for example, piping systems utilizing cyclone separators) are also available depending on the specific application. See cyclone separator arrangement at bottom right of page 6. Please consult the Fybroc factory or your local distributor for proper flush system selection.

LEVEL CONTROLS

Fybroc can provide a number of different systems to control pump operation as the liquid level varies. Three typical systems are described on this page. The number of components required by each is determined by the type of operation and number of pumps being controlled.

Float type (Fig. 1)

Float-type level control utilizes field-adjustable polypropylene floats which contain mercury switches that actuate when the float becomes horizontal. Each float is secured to a PVC support pipe mounted to either a pit cover or a pump mounting plate, and each is supplied with 20 feet (6.1 m) of PVC cable.

Displacer type (Fig. 2)

Displacer-type level control is furnished with porcelain displacers connected to a flange-mounted switch by alloy wire and cable clamps. The wire and clamps are selected to suit the specific application and are normally 316SS, Alloy 20, Hastelloy-C or Monel. To prevent swirling liquids in the sump from improperly activating the switch, the displacers are frequently mounted inside a fiberglass stilling tube.

Probe type (Fig. 3)

Probe-type level control uses either solid rod or adjustable wire suspension electrodes, one for each actuation level. The circuit from an electrode to an external relay is made or broken when the liquid level touches or loses contact with that electrode. Electrodes are attached to a flange-mounted holder which in turn is mounted on either a pit cover or pump mounting plate.

STARTERS/CONTROL PANELS

When desired, Fybroc can supply customized control panels in a variety of enclosures containing starters, alternators, relays, alarms or any other components needed to complete the pump control system. Please contact your Fybroc distributor for additional information.

Fig. 1

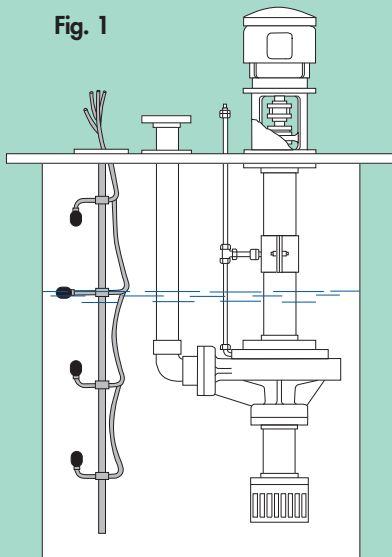

Float-type level controls

Fig. 2

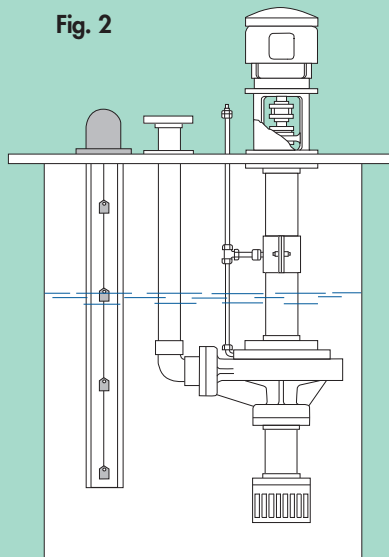

Displacer-type level controls

Fig. 3

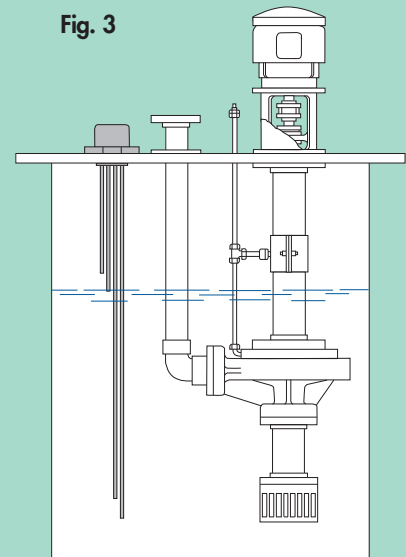

Probe-type level controls

FYBROC SERIES 5500 – HYDRAULIC COVERAGE CHARTS

1150 RPM

60 HERTZ

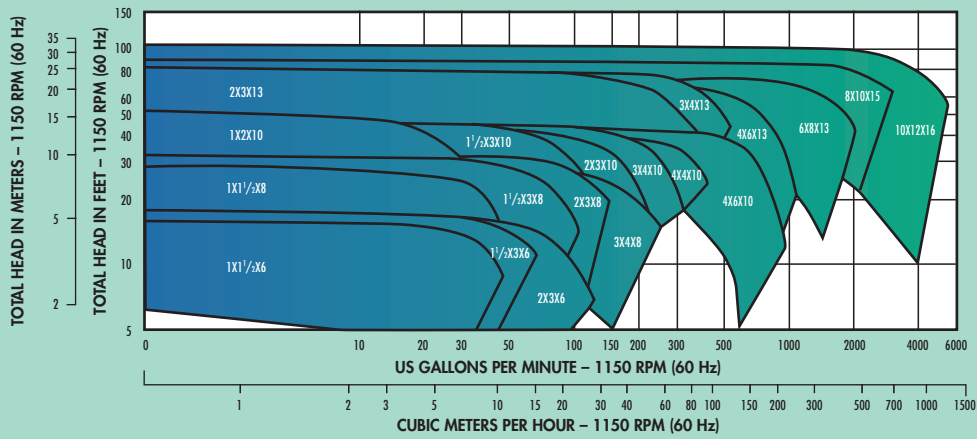

1750/1450 RPM

60/50 HERTZ

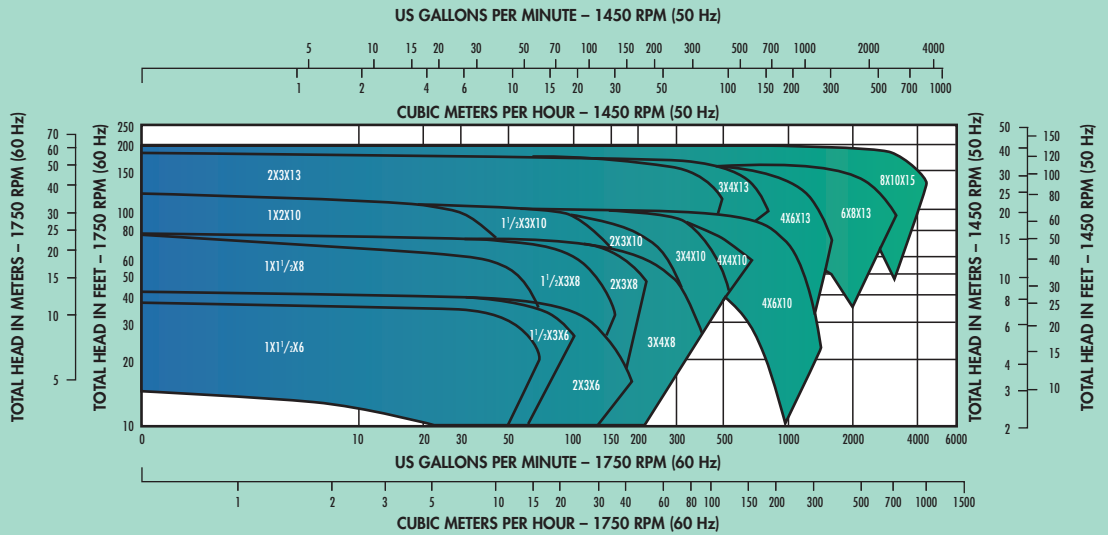

3500/2900 RPM

60/50 HERTZ

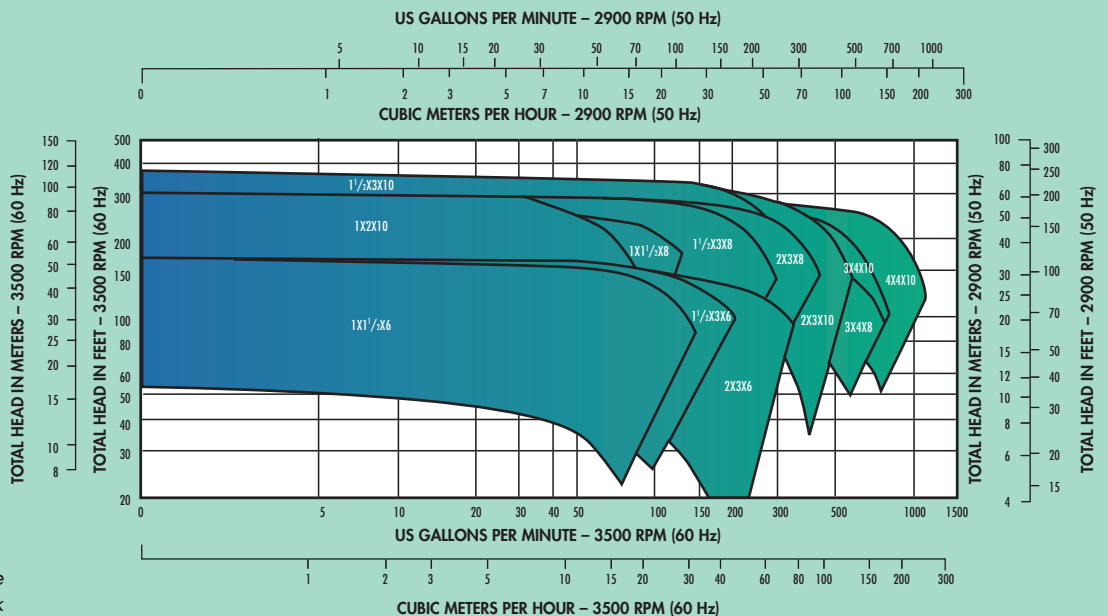

NOTE: For specific performance curves, refer to curve book or www.mp-gps.com.

ENGINEERING INFORMATION – SERIES 5500

PUMP IMPELLER DIAMETER X SUCTION X DISCHARGE		1 x 1.5 x 6	1.5 x 3 x 6	2 x 3 x 6	1 x 1.5 x 8	1.5 x 3 x 8	2 x 3 x 8	3 x 4 x 8	1 x 2 x 10	1.5 x 3 x 10	2 x 3 x 10	3 x 4 x 10	4 x 4 x 10	4 x 6 x 10	2 x 3 x 13	3 x 4 x 13	4 x 6 x 13	6 x 8 x 13	8 x 10 x 15	10 x 12 x 16
MAX. SPHERE SIZE/IMPELLER		.375 (9.53)	.500 (12.70)		.313 (7.95)	.625 (15.90)	1.000 (25.40)	.188 (4.78)		.375 (9.53)	.625 (15.90)	.750 (19.05)	1.000 (25.40)	.313 (7.95)	.500 (12.70)	1.000 (25.40)	1.125 (28.60)	1.750 (44.45)	1.37 (35.00)	
MAX. SPHERE SIZE/STRAINER		.375 (9.53)	.438 (11.11)		.375 (9.53)	.438 (11.11)	.500 (12.70)		.438 (11.11)		.500 (12.70)	.625 (15.90)	.438 (11.11)	.500 (12.70)	.625 (15.90)		1.000 (25.40)			
CASING DATA	IMPELLER CLEARANCE	FRONT		.015 (.38)		.020 (.51)		.025 (.64)												
	IMPELLER CLEARANCE	BACK		.045 (1.04)		.040 (1.02)		.035 (.89)												
CASING THICKNESS (MIN)		.500 (12.70)		.750 (19.05)		.625 (15.90)		.750 (19.05)		.625 (15.90)		1.125 (28.60)		.750 (19.05)		1.250 (31.75)		1.375 (35.00)		
VOLUTE		SINGLE				DOUBLE		SINGLE		DOUBLE				SINGLE		DOUBLE				
SHAFT AND BEARING DATA	DIA. AT IMPELLER		.750 (19.05)		1.250 (31.75)												1.500 (38.10)			
	DIA. AT SLEEVE BEARINGS		1.125 (28.60)		1.500 (38.10)						1.750 (44.45)				2.250 (57.15)					
	DIA. AT COUPLING		.875 (22.22)						1.125 (28.60)				1.375 (35.00)				2.375 (60.32)			
	MAX. BEARING SPAN		30.000 (762.00)																	
	THRUST BEARING NO.		307SZZ						309SZZ				5308MZ				5311MZ			
	THRUST BEARING LUBRICATION		Sealed, Greased-for-Life												Regreasable					
	1ST CRITICAL SPEED		5675 RPM				7560 RPM								8830 RPM				11350 RPM	
	MAX. SHAFT HP (KW) PER 100 RPM		.9 (.67 KW)				1.1 (.82 KW)				2.3 (1.72 KW)				4.0 (2.98 KW)				12.0 (8.95 KW)	

DIMENSIONS SHOWN ARE IN INCHES AND (MILLIMETERS)

FYBROC SERIES 5500 PUMP DIMENSIONS

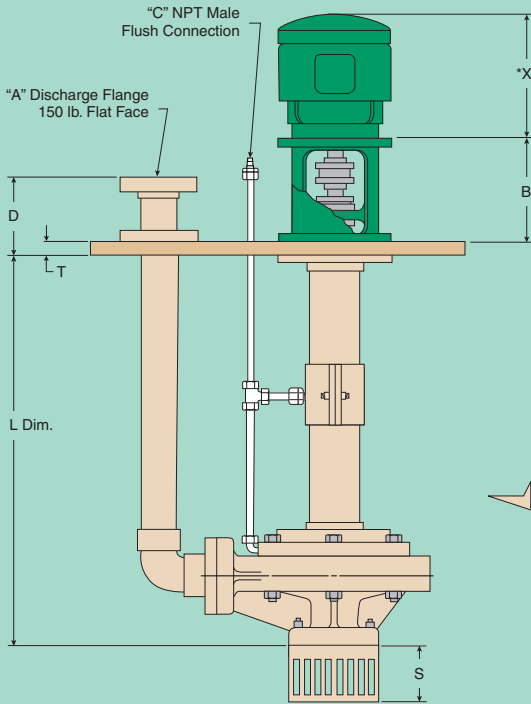

MOTOR FRAME	X*
143 - 145 TC	10 (254)
182 - 184 TC	15 (381)
213 - 215 TC	19 (483)
254 - 256 TC	24 (610)
284 - 286 TC	25 (635)
324 - 326 TC	28 (711)
364 - 365 TC	33 (838)
404 - 405 TC	37 (940)
444 - 445 TC	43 (1092)

* "X" dimension is approximate and may vary according to motor manufacturer.

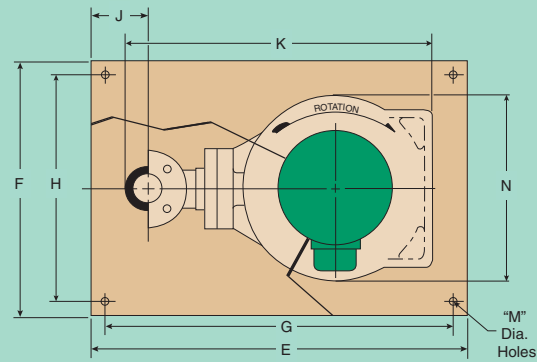
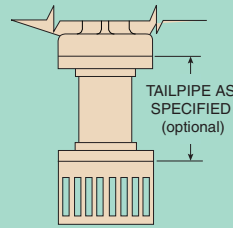

THE ABOVE DRAWING IS NOT TO BE USED FOR CONSTRUCTION PURPOSES.

PUMP IMPELLER X SUCTION X DISCHARGE	1 x 1.5 x 6	1.5 x 3 x 6	2 x 3 x 6	1 x 1.5 x 8	1.5 x 3 x 8	2 x 3 x 8	3 x 4 x 8	1 x 2 x 10	1.5 x 3 x 10	2 x 3 x 10	3 x 4 x 10	4 x 4 x 10	4 x 6 x 10	2 x 3 x 13	3 x 4 x 13	4 x 6 x 13	6 x 8 x 13	8 x 10 x 15	10 x 12 x 16													
A	2 (51)			3 (76)			2 (51)		3 (76)		4 (102)		2 (51)		3 (76)		4 (102)		6 (152)		8 (203)		10 (254)									
B	10 ¹ / ₈ (257)						12 (305)						12 ⁷ / ₁₆ (316)						15 ³ / ₄ (400)													
C	1/4												3/8																			
D	5 ⁵ / ₈ (143)			6 (152)						6 ¹ / ₂ (165)						8 (203)		8 ¹ / ₂ (216)		8 ¹ / ₄ (210)												
E	24 (610)			30 (762)			34 (864)			30 (762)			34 (864)		36 (914)		42 (1067)		36 (914)		40 (1016)		42 (1067)		52 (1321)		66 (1676)		82 (2083)			
F	15 (381)			20 (508)						24 (610)						32 (813)		30 (762)		32 (813)		36 (914)		42 (1067)		48 (1219)						
G	22 (559)			28 (711)			32 (813)			28 (711)			32 (813)		34 (864)		39 (991)		33 (838)		37 (940)		39 (991)		49 (1245)		62 (1575)		78 (1981)			
H	13 (330)			18 (457)						22 (559)						29 (737)		27 (686)		29 (737)		33 (838)		38 (965)		44 (1118)						
J	4 ¹ / ₈ (105)			5 (127)		4 ¹ / ₂ (114)		5 ¹ / ₂ (140)		5 (127)			4 ¹ / ₂ (114)		5 ¹ / ₂ (140)		6 (152)		7 ¹ / ₂ (191)		5 ¹ / ₂ (140)		7 (178)		7 ¹ / ₂ (191)		8 ¹ / ₂ (216)		11 (279)			
K	18 ³ / ₈ (467)			23 ³ / ₈ (594)		24 ³ / ₈ (619)		27 (686)		23 ³ / ₈ (594)			24 ³ / ₈ (619)		27 (686)		30 ¹ / ₄ (768)		33 (838)		28 ¹ / ₈ (714)		30 ¹ / ₄ (768)		33 (838)		42 ³ / ₄ (1086)		54 ¹ / ₂ (1384)		71 ³ / ₄ (1822)	
M	3/4 (19)												1 (25)																			
N	10 ¹ / ₈ (257)			14 ¹ / ₄ (362)						17 ¹ / ₄ (438)						22 ¹ / ₄ (565)		20 ¹ / ₂ (521)		22 ¹ / ₄ (565)		27 ³ / ₄ (705)		32 ¹ / ₂ (826)		39 ¹ / ₂ (1003)						
S	3 ¹ / ₈ (79)		4 ¹ / ₂ (114)		3 ¹ / ₈ (79)		4 ¹ / ₂ (114)		5 (127)		4 ¹ / ₂ (114)			5 (127)		6 ³ / ₄ (171)		7 (178)		4 ¹ / ₂ (114)		5 (127)		7 (178)		10 (254)		14 (356)				
T	5/8 (16)			1 (25)						1 ¹ / ₂ (38)						2 (51)																

DIMENSIONS SHOWN ARE IN INCHES AND (MILLIMETERS)

Standard pump lengths (L Dim.) are available in 6 inch (152.4 mm) increments. For specific pump outline drawings, refer to www.fybroc.com.

OPTIONAL FIBERGLASS – WRAPPED SHAFT

Fybroc's Series 5500 vertical sump pumps are generally offered with the following shaft materials of construction: 316SS, Alloy-20, Titanium, Hastelloy-C, and additional alloys upon special request from the factory. For highly corrosive applications/services typically requiring higher alloy metal shafting (for example, Titanium, Hastelloy-C, etc.), Fybroc offers an optional shaft material specifically designed to be a more cost effective and corrosion-resistant alternative. This option, a fiberglass-wrapped 303SS shaft,

is available on all Fybroc Series 5500 Group I, Group II, and Group III short setting pumps with a maximum pump length/L Dimension of 36 inches (914.4 mm). The wrapped shaft is designed to provide the same corrosion resistance as other FRP components (such as casing, cover, impeller, etc.) that constitute the Series 5500 pump. See Figures 1, 2, and 3.

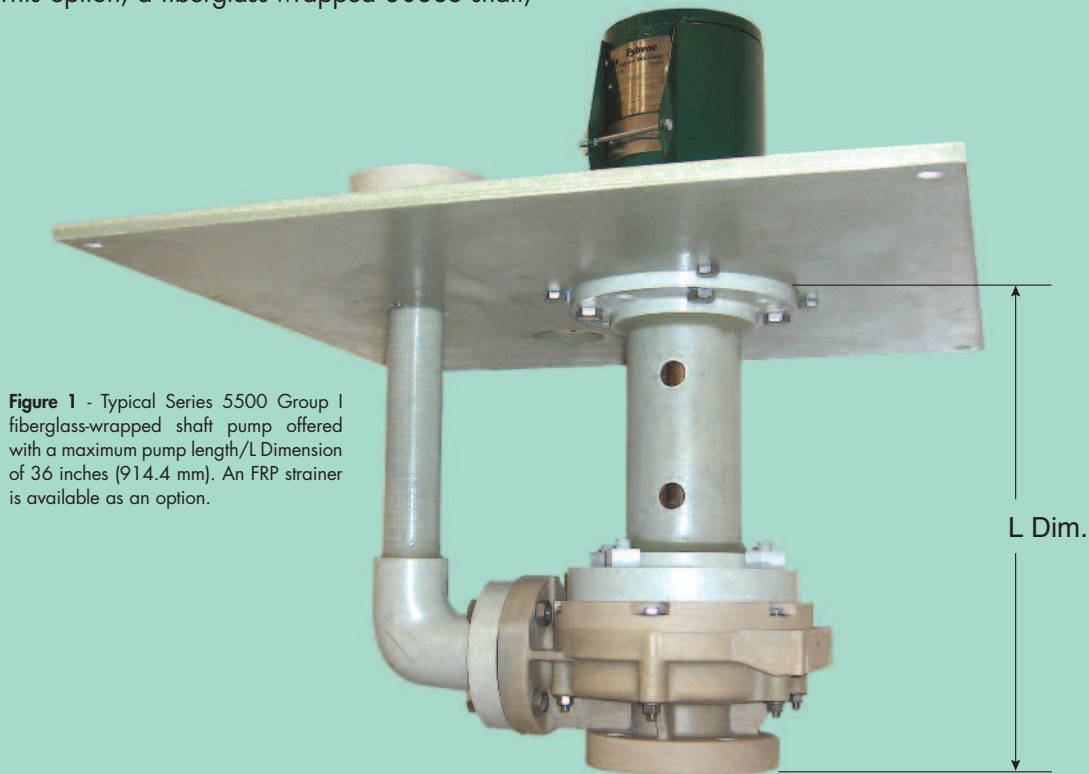

Figure 1 - Typical Series 5500 Group I fiberglass-wrapped shaft pump offered with a maximum pump length/L Dimension of 36 inches (914.4 mm). An FRP strainer is available as an option.

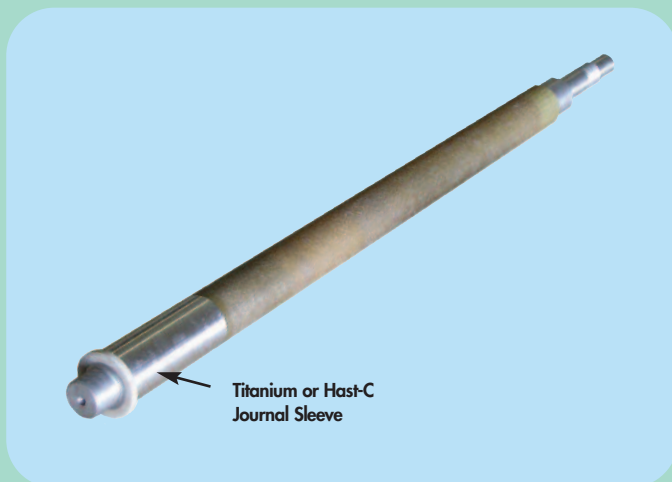

Figure 2 - Typical fiberglass-wrapped 303SS shaft. The shaft is available with either a Titanium or Hastelloy-C Journal Sleeve for the lower sleeve bearing located in the pump cover.



Figure 3 - Cross-section of a fiberglass-wrapped 303SS shaft. The cross-section shows the core, non-wetted, 303SS shaft and is meant to highlight the shaft's substantial fiberglass-reinforced wrapping, greater than 1/8" (3.2 mm).

**The world's most
complete line of
pumps for handling
corrosive and
other difficult liquids**



ABOUT MET-PRO GLOBAL PUMP SOLUTIONS

Met-Pro Global Pump Solutions, which combines the resources of the Company's internationally recognized Dean Pump®, Fybroc® and Sethco® brands, is a leading niche-oriented global provider of solutions and products for the pumping of corrosive, abrasive and high temperature liquids. Its broad range of high quality centrifugal pumps provide excellent performance for tough applications including pumping of acids, brines, caustics, bleaches, seawater, high temperature liquids and a wide variety of waste liquids for a broad range of applications including the chemical, petrochemical, metal finishing, wastewater treatment, desalination and aquarium/aquaculture markets. For more information, visit www.mp-gps.com.

ABOUT MET-PRO

Met-Pro Corporation is a global provider of solutions and products for product recovery, pollution control and fluid handling applications. The Company's products include filtration and purification equipment for air, water and harsh, corrosive applications; fluid handling equipment for water, corrosive, abrasive, and high temperature liquids; and proprietary water treatment chemicals. For more information, visit www.met-pro.com.



A Met-Pro Fluid Handling Technologies Business
Combining the Resources of **Dean Pump, Fybroc & Sethco**

700 Emlen Way • Telford, PA 18969
P: 215.723.8155 • TOLL-FREE: 800.FYBROC.1 • F: 215.723.2197
info@mp-gps.com • www.mp-gps.com



© 2013 MET-PRO CORPORATION
FYBROC® IS A REGISTERED TRADEMARK OF MET-PRO CORPORATION 07-5306 413

