

A B E G J Q



# Self Priming Centrifugal

## For Power-Take-Off Drive

### Model 02F1-G

### Size 2" x 2"



**PUMP SPECIFICATIONS**

Size: 2" x 2" NPT-Female  
 Casing: Aluminum No. 356-T6  
 (Maximum Operating Pressure 235 lbs.)  
 Impeller: Enclosed Type, 6 Vanes, Almag No. 35  
 Pinion Shaft: Allow Steel 4320  
 Wear Ring; Replaceable: Brass No. C83600  
 Cover Plate; Removable: Gray Iron No. 30—5.6 lbs  
 Gear Housing: Gray Iron No. 30  
 Seal: Type 21. Mechanical Self-Lubricated.  
 Rotating Faces are Carbon.  
 Stationary Faces are Ni-Resist.  
 Elastomers are Viton.  
 Cage and Spring are Stainless Steel.  
 Maximum Temperature of Liquid Pumped, 160°F  
 Seal Guard: Brass Tubing  
 Radial Bearing: Open Ball  
 Thrust Bearing: Open Ball  
 Bearing Lubrication: Oil  
 Flanges: Gray Iron No. 30  
 Gaskets: Cork & Buna, Vegetable Fiber  
 Optional Equipment:  
 Victaulic Elbow

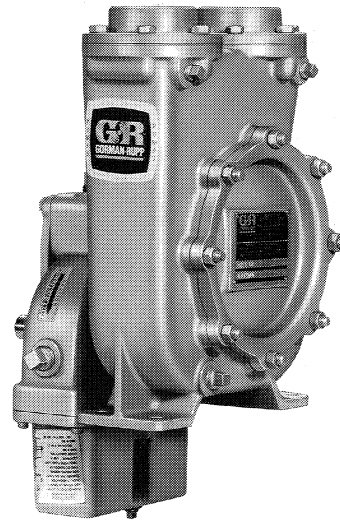

ROTATION: Clockwise facing pump input shaft, specify Model 02F1-GR; Counterclockwise facing input shaft specify Model 02F1-GL.

DIMENSIONS INCHES (MILLIMETERS)

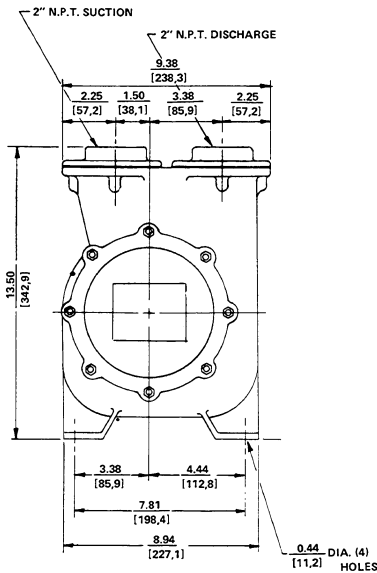

MODEL 02F-GL

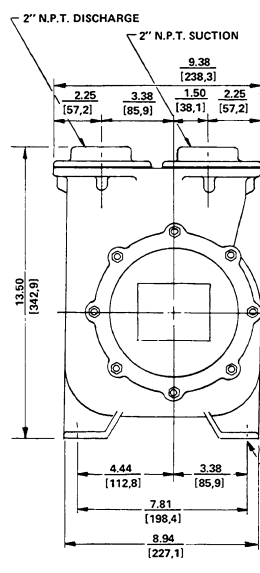

MODEL 02F-GR

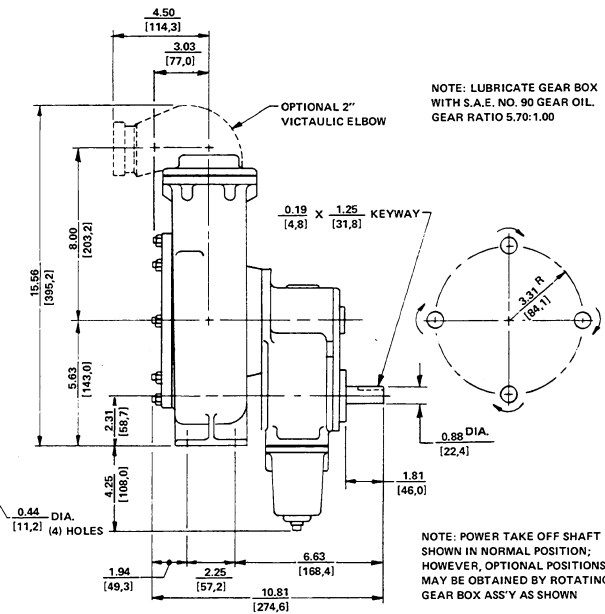

MODEL 02F-GL  
MODEL 02F-GR



THE GORMAN-RUPP COMPANY • MANSFIELD, OHIO

GORMAN-RUPP OF CANADA LIMITED • ST. THOMAS, ONTARIO, CANADA

Printed in U.S.A.

# Specification Data

SECTION 110, PAGE 550

OVERALL DIMENSIONS  
and  
WEIGHTS APPROXIMATE

NET WEIGHT:  
SHIPPING WEIGHT:  
EXPORT CRATE SIZE:

52 POUNDS  
69 POUNDS  
2.1 CUBIC FEET

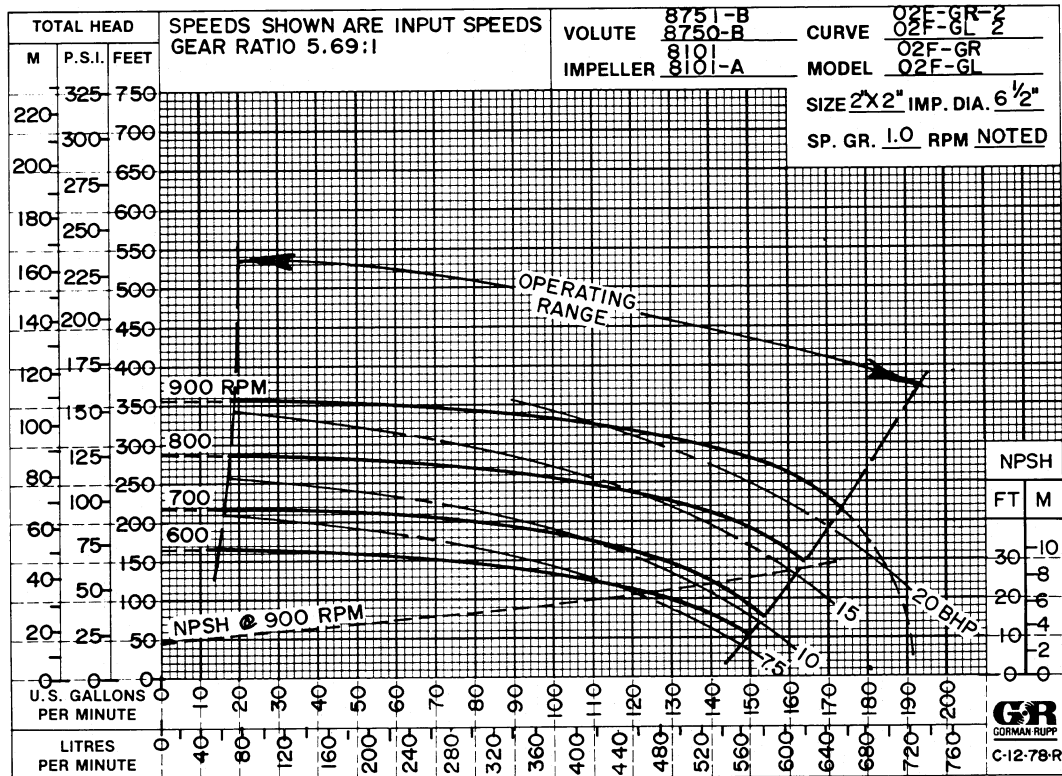
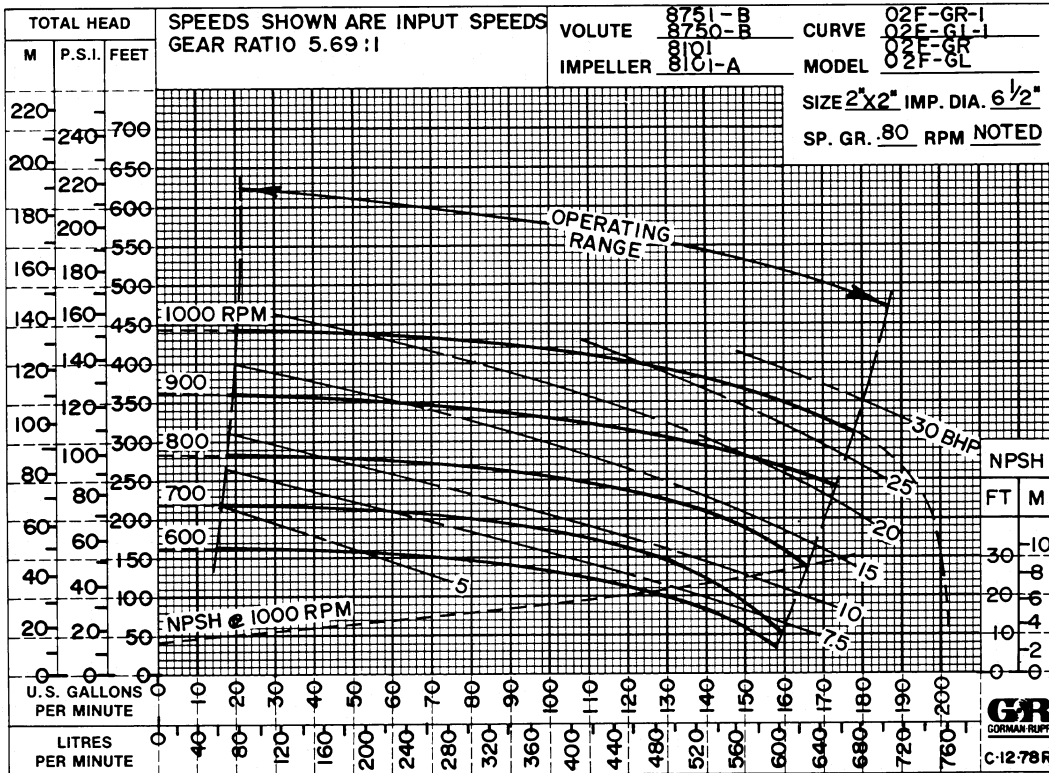

THE GORMAN-RUPP COMPANY • MANSFIELD, OHIO

GORMAN-RUPP OF CANADA LIMITED • ST. THOMAS, ONTARIO, CANADA

Printed in U.S.A.