

wright flow

TECHNOLOGIES



Capacity to 310 GPM/70 M³/hr

Pressure to 500 PSI/34 Bar

Viscosity to 910,000 SSU (200,000 cSt)

Temperature -40° to 300° F (-40° to 150° C)

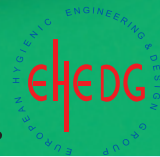
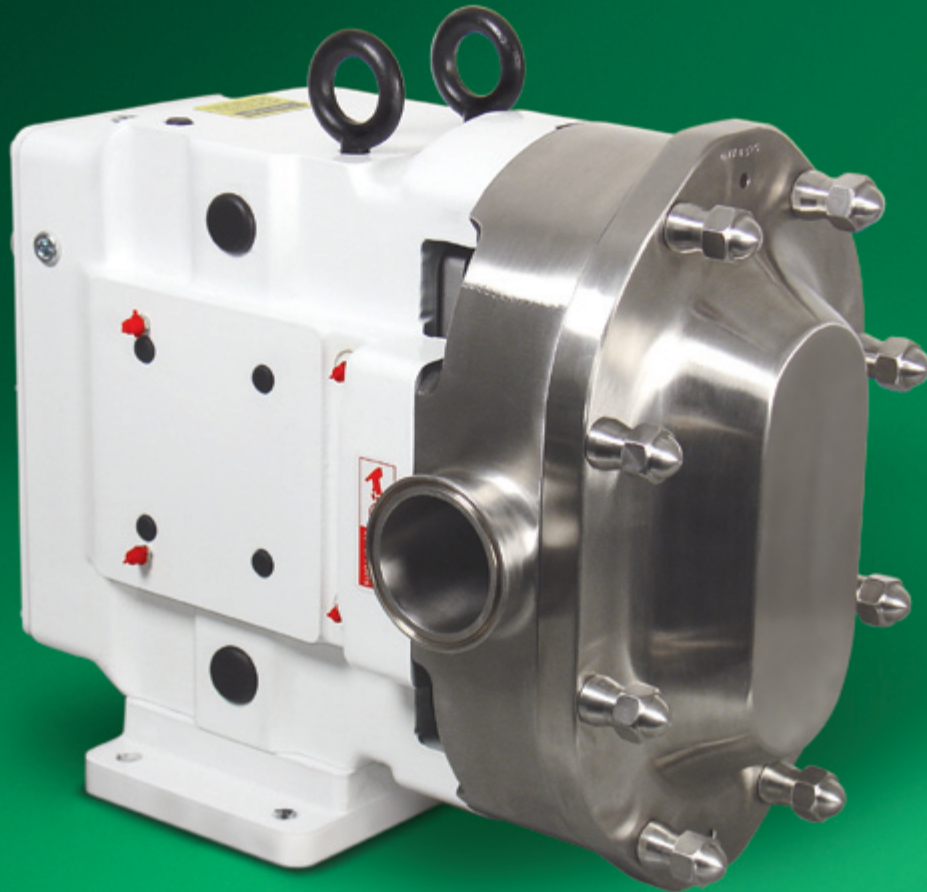

SANITARY POSITIVE DISPLACEMENT PUMPS

TRA[®] 20 Series



TRA[®] 20 Pump Series



The reliability of Wright Flow Technologies positive displacement circumferential piston pumping principle has been proven over many decades. Its robust design and easy cleanability make it applicable for all sanitary fluids.

Wright Flow Technologies gentle action on shear-sensitive liquids, or slurries with soft solids, makes them the preferred technology for all areas of food processing, beverage and cosmetic manufacturing, worldwide.



Typical Applications

- ▶ **Dairy:** milk, cream, curds, butter, soft cheese, yogurt, butter, margarine, ice cream
- ▶ **Bakery:** yeast, dough, fruit filling, icing, fats and oils
- ▶ **Meats:** sausage filling, fats, broths, gelatins, pet food
- ▶ **Canned Foods:** potato salad, baby food, soups, stews, tomatoes, relishes, pudding, dressings, mayonnaise, jams and jellies
- ▶ **Beverages:** beer, mash, wort, fruit juices, fruit concentrate
- ▶ **Candy:** sugars, chocolate, cocoa butter, corn syrup, gelatin
- ▶ **Flavorings:** syrups and concentrates
- ▶ **Dressings:** Mayonnaise and other prepared sauces
- ▶ **Cosmetics:** creams, lotions, jellies, shampoos, emulsions, toothpaste
- ▶ **Pharmaceuticals:** fermentation broths, cell cultures, blood products, pill coatings and membrane separation processes
- ▶ **Industrial:** automotive paints, inks, latex, polymers

Construction

- ▶ **Casing:** 316 Stainless Steel, interior finished to 3A standards.
- ▶ **Rotors:** "Wright Flow Technologies 808" non-galling, nickle-based alloy. Wright Flow Technologies manufactures the material in its own foundry for maximum quality control.
- ▶ **Shafts:** 17-4 PH High-Strength Steel Shafts on all sizes.
- ▶ **Bearing Retainers:** Stainless Steel.
- ▶ **Gear case:** Powder-coated iron gear case standard (FDA white, RAL 9003).
- ▶ **Seals:** Single mechanical seal with Silicon Carbide / Silicon Carbide faces standard. Double mechanical seal optional.
- ▶ **Timing Gears:** Helical gear design to minimize operating noise.
- ▶ **Cleaning Options:** Clean-In-Place design optional, including self-draining rotor case (in vertical orientation) with cover O-ring exposed to cleaning fluid, and hubs and rotors ported to ensure thorough flushing action.

TRA[®]20 Pump Performance

TRA [®] 20 Model	Nominal Capacity		Displacement per Revolution		Maximum Pressure		Temperature Range		Viscosity Range		Standard Ports		Optional Ports		Maximum Speed (RPM)
	GPM	M ³ /hr	Gal.	Liter	PSI	Bar	Deg. F	Deg. C	SSU	cSt	in.	mm	in.	mm	
0060	8	1.8	.008	.030	300	21	-40° to 300° *	-40° to 150° *	28 to 910,000	1 to 200,000	1.0	25.4	1.5	38	1000
0150	11	2.5	.014	.052	250	17	-40° to 300° *	-40° to 150° *	28 to 910,000	1 to 200,000	1.5	38.0	—	—	800
0180	20	4.5	.029	.108	200	14	-40° to 300° *	-40° to 150° *	28 to 910,000	1 to 200,000	1.5	38.0	2.0	51	700
0300	36	8.2	.060	.227	250	17	-40° to 300° *	-40° to 150° *	28 to 910,000	1 to 200,000	1.5	38.0	2.0	51	600
0450	58	13.2	.096	.366	450	31	-40° to 300° *	-40° to 150° *	28 to 910,000	1 to 200,000	2.0	51.0	—	—	600
0600	90	20.4	.150	.568	300	21	-40° to 300° *	-40° to 150° *	28 to 910,000	1 to 200,000	2.5	64.0	3.0	76	600
1300	150	34.1	.250	.946	200	14	-40° to 300° *	-40° to 150° *	28 to 910,000	1 to 200,000	3.0	76.0	—	—	600
1800	230	52.2	.383	1.45	450	31	-40° to 300° *	-40° to 150° *	28 to 910,000	1 to 200,000	3.0	76.0	—	—	600
2100	300	68.1	.500	1.89	500	34	-40° to 300° *	-40° to 150° *	28 to 910,000	1 to 200,000	4.0	102.0	—	—	600
2200	310	70.4	.516	1.95	300	21	-40° to 300° *	-40° to 150° *	28 to 910,000	1 to 200,000	4.0	102.0	—	—	600

* Hot clearances required for high temperature operation.

TRA [®] 20 Rectangular Flange Model	Nominal Capacity		Displacement per Revolution		Maximum Pressure		Temperature Range		Inlet (W x L)		Outlet		Maximum Speed (RPM)
	GPM	M ³ /hr	Gal.	Liter	PSI	Bar	Deg. F	Deg. C	in.	mm	in.	mm	
0240	11.6	2.5	.03	.11	200	14	-40° to 300°	-40° to 150°	1.31 x 4.63	33.27 x 125.22	1.5	38.1	400
0340	24.0	5.4	.06	.23	200	14	-40° to 300°	-40° to 150°	1.75 x 6.75	44.50 x 171.45	1.5	38.1	400
0640	60.0	13.6	.15	.57	200	14	-40° to 300°	-40° to 150°	2.24 x 8.82	56.90 x 224.03	2.5	57.15	400
1340	100.0	22.7	.25	.95	200	14	-40° to 300°	-40° to 150°	2.97 x 9.25	75.44 x 234.95	3.0	76.2	400
2240	200.0	45.4	.52	1.95	200	14	-40° to 300°	-40° to 150°	3.87 x 11.00	98.30 x 279.40	4.0	101.6	400

Installation Positions 4-Way Mounting

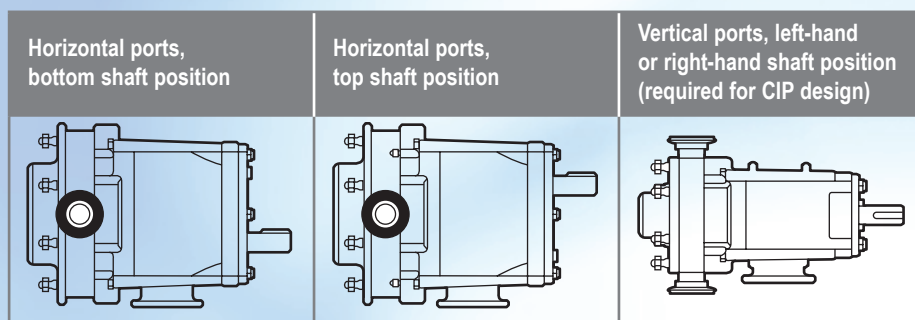

The mounting foot may be moved to any of four positions to allow horizontal or vertical porting and flexibility of driver connection.

Port Configurations

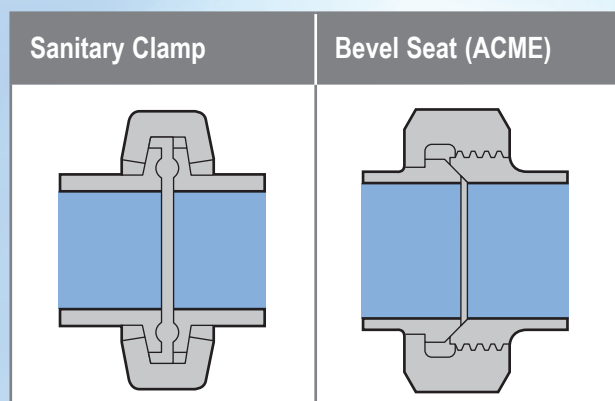

Other port configuration options include:

- ▶ DIN 11851
- ▶ RJT
- ▶ NPT
- ▶ SMS
- ▶ 150# or 300# flange

Performance Range

- ▶ **Capacity Range:** 0.1 to 310 gpm (0.02 to 70.4 m³/hr)
- ▶ **Pressure Range:** to 500 PSI/34 Bar
- ▶ **Temperature Range:** -40°F to +300°F (-40°C to +150°C)
Note: Hot clearances required for high temp operation
- ▶ **Viscosity Range:** 28 to 910,000 SSU (1 to 200,000 cSt)
Note: Consult factory for applications greater than 910,000 SSU/200,000 cSt. Chocolate clearances available.

TRA[®]20 Features

- ▶ Time tested and proven circumferential piston design.
- ▶ Exceptional engineering and manufacturing quality.
- ▶ Parts are interchangeable with Waukesha[®] U2 series pump parts.
- ▶ Wright Flow Technologies TRA[®]20 pumps are drop-in replacements for equivalent sized Waukesha[®] U2 pumps.
- ▶ Wright Flow Technologies can remanufacture TRA[®]20 series or Waukesha[®] U2 series pumps up to three times.

Choosing between TRA[®]20 and TRA[®]10 series pumps

- ▶ The TRA[®]20 series allows optional Clean-In-Place design. CIP-ing can reduce cleaning time and labor between batches, for maximum productivity.
- ▶ Most TRA[®]20 models offer higher pressure capabilities than their equivalent TRA[®]10 model, all of which are rated to 200 PSI (14 Bar), except the model TRA[®]10 0450, which is rated to 400 PSI (27 Bar).

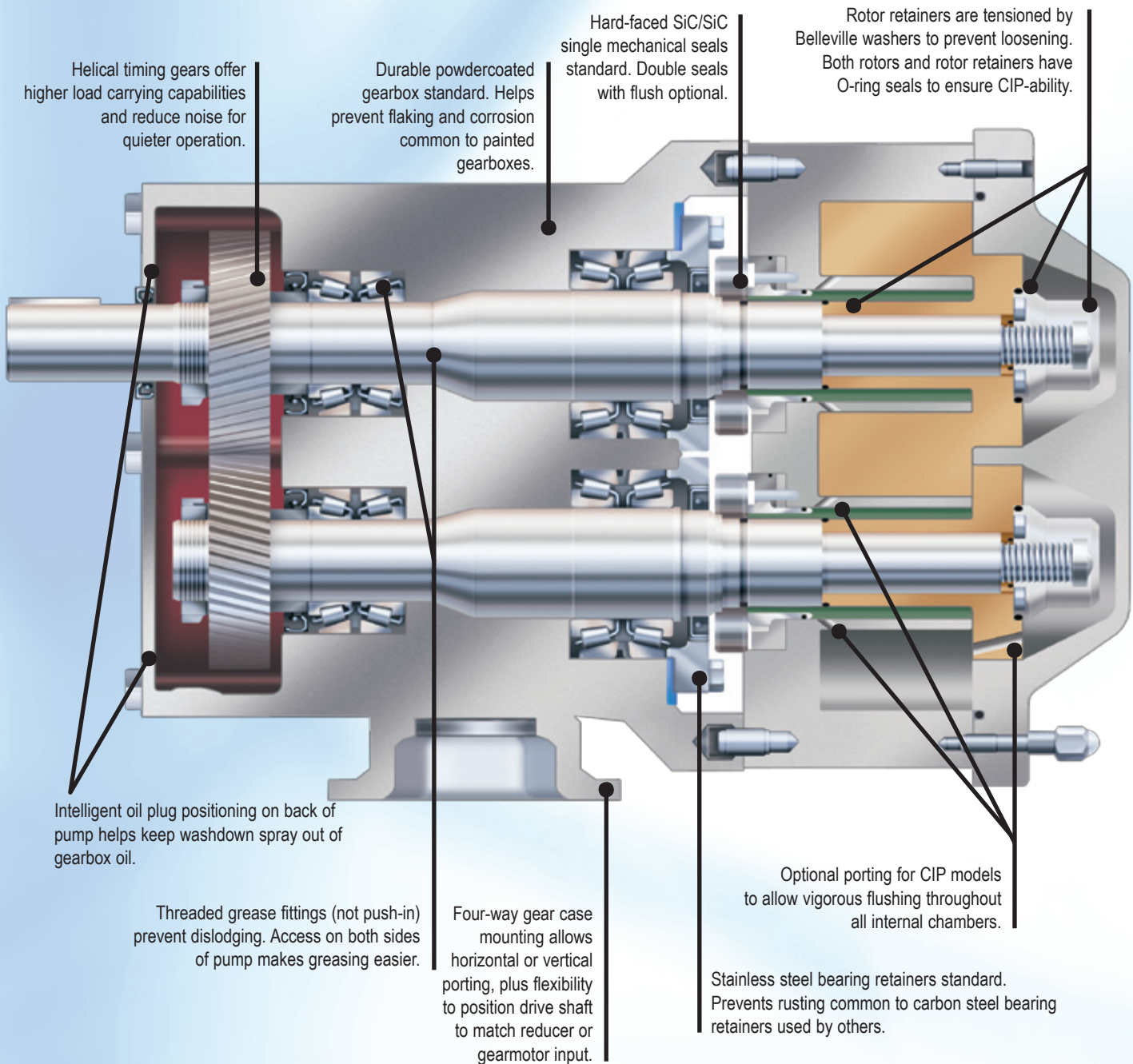

Shaft Sealing Options

...for different liquids and conditions of service

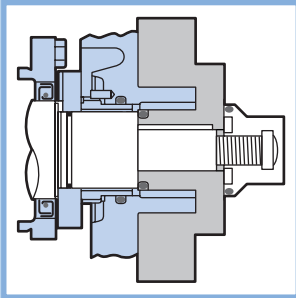

Single Mechanical Seals

- ▶ Standard Seal Faces: SiC/SiC
- ▶ Standard O-rings and Cover Seals: Buna
- ▶ Optional Faces: Carbon, Ceramic or Chrome Oxide
- ▶ Optional O-rings and Cover Seals: FKM, EPDM, Silicone

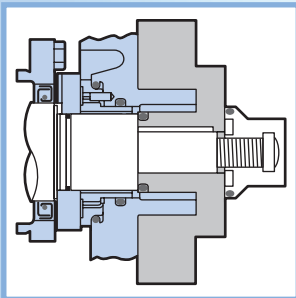

Double Mechanical Seals with Flush

- ▶ Standard Seal Faces: SiC/SiC
- ▶ Standard O-rings and Cover Seals: Buna
- ▶ Optional Faces: Carbon, Ceramic or Chrome Oxide
- ▶ Optional O-rings and Cover Seals: FKM, EPDM, Silicone

Remanufacturing Value

We offer unrivaled value by remanufacturing worn Wright Flow Technologies® and Waukesha® circumferential piston pumps to like-new condition with increased efficiency and reduced slip for enhanced productivity.

Wright Flow Technologies will replace all parts except the cover, rotor case, gear case in their remanufacturing process, and provide you a one-year warranty on the work. Machined in 0.020" increments as required by wear, the rotor case and cover are outfitted with corresponding oversized rotors. The TRA®10 can be remanufactured up to 4 times, and the TRA®20 up to three times for unmatched savings and a better bottom-line. Wright Flow Technologies remanufacture and complete factory bench tests to certify your pumps perform from day one and beyond. Best of all, having your Waukesha pumps remanufactured by Wright Flow Technologies gets you all of our improved features such as:

- ▶ 17-4 PH Material shafts
- ▶ Helical timing gears for higher load carrying and quieter operation
- ▶ Stainless steel bearing retainers for increased corrosion resistance

Rotors

Twin Wing Rotors Standard.

Suitable for all liquids, provides minimum pulsation.

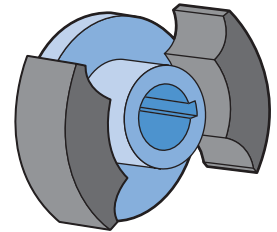

Single Wing Rotors Optional.

Provides reduced shear on shear-sensitive fluids or large solids such as fruit pieces, nut kernels, cheese curds or meats.

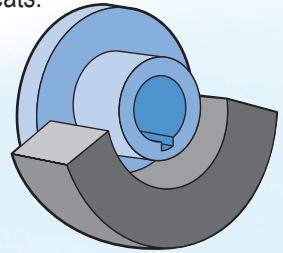

Wright Flow Technologies Positive Displacement Circumferential Piston Pumping Principle



Wright Flow Technologies rotor wings (pistons) rotate around the circumference of the channel in the pump casing. This continuously generates a partial vacuum at the suction port as the rotors unmesh, causing fluid to enter the pump. The fluid is transported around the channel by the rotor wings, and is displaced as the rotor wings converge, generating pressure at the discharge port. Pump output is directly proportional to speed, and direction of flow is reversible.

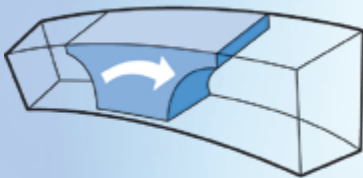

A

The deep channels in which the rotors travel provide large voids to minimize shear and bruising of solids.

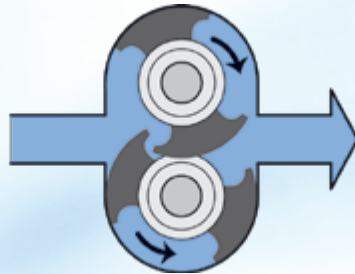

B

The rotors are made of "Wright Flow Technologies 808" non-galling alloy, allowing extremely tight clearances between rotating and stationary surfaces, which ensures high efficiency and metering accuracy, even on thin liquids.

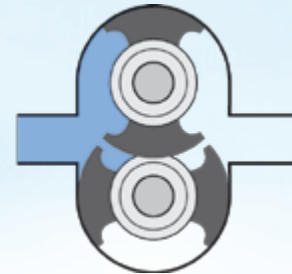

C

The forward part of each non-galling rotor rotates in a recess in the pump head to minimize deflection even at high discharge pressures.



Suction

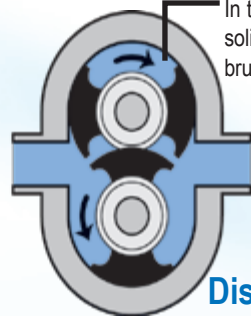

Discharge

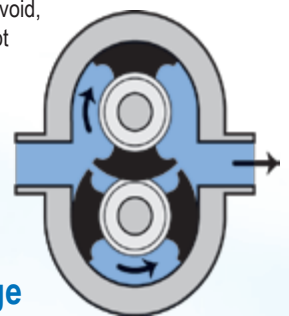

In this large void, solids are not bruised.

TRA[®]20 Dimensions

Model		A	B	C	D	E	F	G	H	I	J	K	L	M	N	O	P	Q	Ø	R	S	Weight
0060	in.	4.75	1.95	3.75	11.71	5.50	1.94	2.31	0.375 x 0.31 (slot)	6.82	2.93	9.61	2.12	2.00	4.21	1.50	2.79	0.875	3.49	6.97	53 lb.	
	mm	121	50	95	297	140	49	59	9.5 x 8 (slot)	173	74	244	54	51	107	38	71	22.23	89	177	24 kg	
0150	in.	4.75	1.95	3.75	11.71	5.50	1.94	2.31	0.375 x 0.31 (slot)	6.82	2.93	9.61	2.12	2.00	4.21	1.50	2.79	0.875	3.49	6.97	53 lb.	
	mm	121	50	95	297	140	49	59	9.5 x 8 (slot)	173	74	244	54	51	107	38	71	22.23	89	177	24 kg	
0180	in.	4.75	2.18	3.75	12.37	5.50	1.94	2.31	0.375 x 0.31 (slot)	6.82	2.93	9.84	2.12	2.00	4.21	1.50	3.02	0.875	3.49	6.97	53 lb.	
	mm	121	55	95	314	140	49	59	9.5 x 8 (slot)	173	74	250	54	51	107	38	77	22.23	89	177	24 kg	
0300	in.	6.25	2.78	4.25	14.49	6.86	2.31	2.56	0.438 x 0.44 (slot)	7.77	3.56	11.61	2.62	2.32	5.21	1.50	3.84	1.250	4.25	8.50	99 lb.	
	mm	159	71	108	368	174	59	65	11 x 11 (slot)	197	90	295	67	59	132	38	98	31.75	108	216	45 kg	
0450	in.	8.25	3.86	5.87	18.59	9.56	3.50	4.12	0.56 x 0.50 (slot)	10.13	5.06	14.86	3.50	2.25	7.31	2.00	4.73	1.625	5.37	10.75	290 lb.	
	mm	210	98	149	472	243	89	105	14 x 13 (slot)	257	129	377	89	57	186	51	120	41.28	136	273	132 kg	
0600	in.	8.25	4.14	5.87	19.14	9.56	3.50	4.12	0.56 x 0.50 (slot)	10.13	5.06	15.14	3.50	2.25	7.31	2.50	5.01	1.625	5.37	10.75	290 lb.	
	mm	210	105	149	486	243	89	105	14 x 13 (slot)	257	129	385	89	57	186	63	127	41.28	136	273	132 kg	
1300	in.	8.25	4.78	5.87	20.15	9.56	3.50	4.12	0.56 x 0.50 (slot)	10.12	5.06	15.77	3.50	2.25	7.31	3.00	5.65	1.625	5.37	10.75	312 lb.	
	mm	210	121	149	512	243	89	105	14 x 13 (slot)	257	129	401	89	57	186	76	144	41.28	136	273	142 kg	
1800	in.	8.50	3.45	9.00	23.26	12.38	3.75	7.25	0.56 x 0.50 (slot)	14.05	6.38	17.75	4.50	2.75	9.38	3.00	4.20	2.000	6.53	13.06	528 lb.	
	mm	216	88	229	591	314	95	184	14 x 13 (slot)	357	162	450	114	70	238	76	107	50.8	166	332	238kg	
2100	in.	12.00	3.45	11.63	27.08	13.88	5.25	8.00	0.66 Ø	16.54	6.88	21.24	5.06	4.06	10.38	4.00	4.70	2.375	7.37	14.73	870 lb.	
	mm	305	88	295	688	353	133	203	16 Ø	420	175	539	129	103	264	102	119	60.33	187	374	395 kg.	
2200	in.	8.50	3.69	9.00	24.00	12.38	3.75	7.25	0.56 x 0.19 (slot)	14.05	6.38	18.49	4.50	2.75	9.38	4.00	4.44	2.000	6.63	13.25	555 lb.	
	mm	216	94	229	610	314	95	184	14 x 5 (slot)	357	162	470	114	70	238	102	113	50.80	168	337	252 kg	

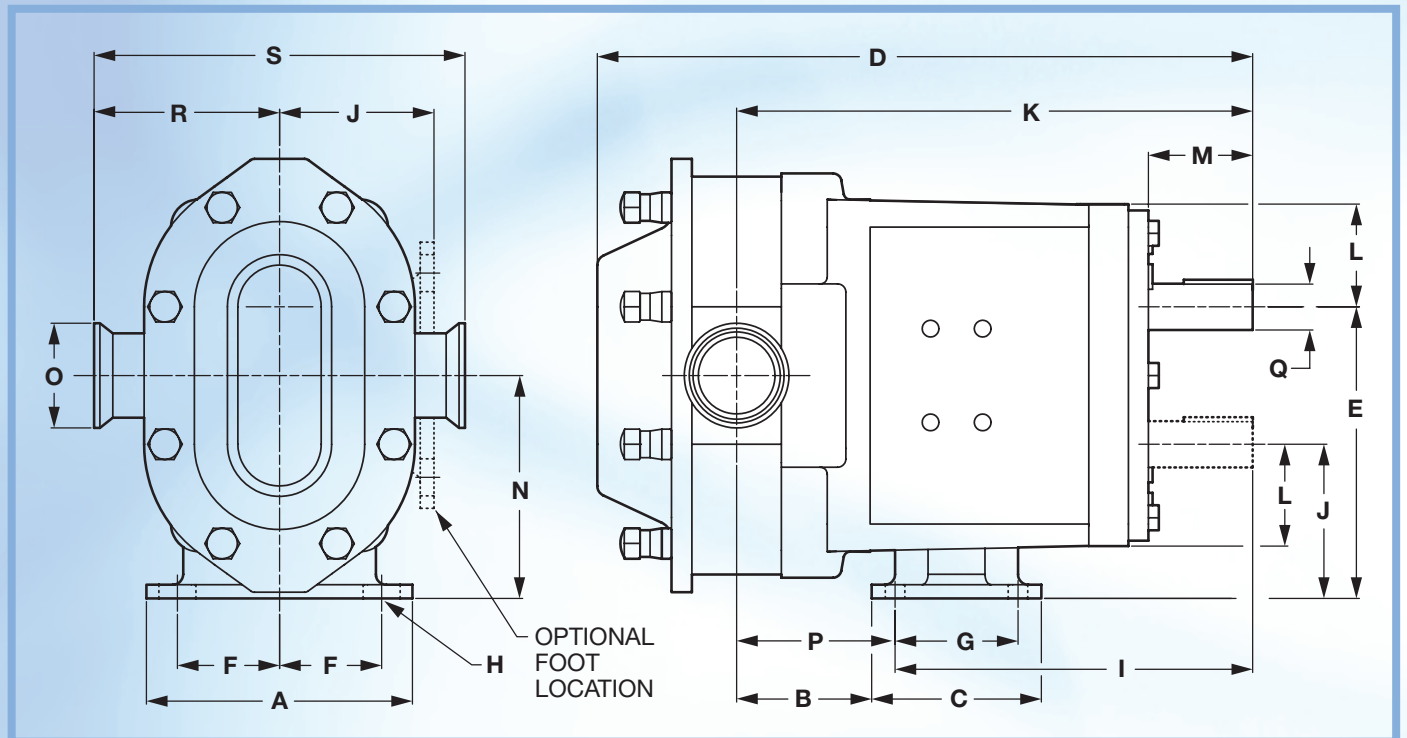

Disclaimer: Dimensions are for guidance only. Please refer to our technical office if a certified drawing is required.

Sanitary Pumps, Parts, Remanufacturing & Accessories

Wright Flow Technologies

Our products are used across the whole of the process industries in applications as diverse as paper & pulp production through to the extreme hygiene end of the pharmaceutical industry on injectables and blood processing. We manufacture within our organization rotary lobe, centrifugal, circumferential piston, air operated double diaphragm and dosing pumps, all manufactured and designed with hygiene, cleanliness, affordability and robustness in mind. These pumps coupled with our range of hygienic turbine and magnetic flow meters, our full range of sanitary valves and our powder mixing technology from Quadro, gives a complete package for the modern high-tech process industries of today.

Remanufacturing in Europe and North America

Wright Flow Technologies offers unique remanufacturing services in Europe and North America for Waukesha® Universal I and Universal II series pumps, as well as Wright Flow Technologies TRA10 and TRA20 series pumps. Remanufacturing is a lower-cost alternative to buying a new replacement pump and it gets you all of Wright Flow Technologies improved features and benefits. Ask your distributor, or the factory for more details.

For more information, contact your local authorized Wright Flow Technologies Distributor or contact us at:



Wright Flow Technologies, Inc.

S84 W18693 Enterprise Drive
Muskego, WI 53150
Phone: (262) 679-8000
Fax: (262) 679-2026
Email: info.wright@idexcorp.com

Wright Flow Technologies Ltd.

Highfield Industrial Estate,
Edison Road Eastbourne
East Sussex, United Kingdom, BN23 6PT
Phone: +44 1323 509211
Fax: +44 1323 507306
E-mail: jinfo@idexcorp.com

Visit us online at:

www.wrightflowtechnologies.com
www.johnsonpump.com
www.wrightpump.com

ASIA-PACIFIC

China	Beijing	- Phone: +86-10-6522-7567/27	Fax: +86-10-6522-7563
	Chengdu	- Phone: +86-28-86767458	Fax: +86-28-86767468
	Guangzhou	- Phone: +86-20-3886-6156	Fax: +86-20-3886-2776
	Shanghai	- Phone: +86-21-5241 5599	Fax: +86-21-5241 8339
South Asia	India	- Phone: +91-22-6678-0048/53	Fax: +91-22-6678-0055
ASEAN	Singapore	- Phone: +65-6763-6633	Fax: +65-6764-4020
Middle East	Dubai	- Phone: +971-4-225-7978	Fax: +971-4-225-9796
Oceania		- Phone: +91-22-6678-0048/53	Fax: +91-22-6678-0055

LATIN AMERICA

Brazil		- Phone: +55-19-3871-3500	Fax: +55-19-3871-6400
Caribbean		- Phone: +1 (305) 740-3365	Fax: +1 (305) 740-3372
Cono Norte/Central America		- Phone: +57 1 648 2761	Fax: +57 1 274 3453
Cono Sur		- Phone: +1 (803) 234-3004	Fax: +1 (803) 216-7670
Mexico		- Phone: +52 55 5255-1357	Fax: +52 55 5255-1356

