

ABS ROBUSTA LIGHT DRAINAGE PUMP 60 Hz

The next generation of submersible pumps for clear and surface water with built-in checkvalve for house, yard and garden. Unique float switch system that offers automatic and manual operation that is rust proof and clog proof, 1/2" solids capacity

Applications

The ABS ROBUSTA has been designed for pumping clear and wastewater from house, garden or yard, and is supplied with built-in level control and checkvalve. The pump and motor section form a pressure-tight encapsulated unit, with motor housing constructed from corrosion resistant material. The outer jacket and impeller are made of durable plastics. The unique hand/auto switch makes the pump suitable for manual or automatic operation.

Construction

- Discharge outlet 1 1/2" with built-in checkvalve.
- Connection chamber with cover and watertight cable inlet and strain relief.
- Outer jacket and other housing parts made of corrosion resistant synthetic material. Motor housing is made of coated aluminium.
- Motor is dynamically balanced with temperature monitor in the stator, which switches off the pump in the case of overheating and switches on automatically after cooling down.
- Shaft is made of stainless steel.
- The sealing on the motor side is by means of special lip seals supported by lubricated ball bearings.
- The medium being pumped flows around the motor housing for optimum heat dissipation.
- The medium temperature is 40° C (104 F); intermittent usage to 60° C (140 F) (max. 5 min).
- The TS version has a built-in automatic level control, with easily removable float cover for cleaning purposes.
- Separate switch for continuous operation in transportable applications.
- The special bayonet clamping allows the screen to be removed by hand in the event an impeller inspection is necessary.

Materials

Pump casing _____ Polypropylene
Motor shaft _____ 1.4021 (AISI 420)
Impeller _____ Polyamide
Seals _____ Neoprene
Cable _____ Neoprene



- Two position manual/automatic switch
- Rust proof polypropylene construction
- Fits into 8" diameter opening
- 1 1/2" female discharge
- Check-valve included
- Environmentally safe oil-free motor
- Air filled capacitor start motor
- Clog proof impeller design
- 1/2" solids handling capability
- Removeable bottom screen for 1/8" pumps down
- UL and CSA listed

ABS ROBUSTA LIGHT DRAINAGE PUMP - 60 Hz

Technical Data

	Discharge connection internal- thread	Solids size inch	Nominal hp	Speed rpm	Rated current at 115 V A	Cable* length ft	Weight lbs
ROBUSTA 100 W/TS	1½"	½	¼	3400	4.1	10	6.6
ROBUSTA 200 W/TS	1½"	½	1/3	3400	5.4	10	7.3
ROBUSTA 300 W/TS	1½"	½	½	3400	5.9	10	8.0

* U.L. listed

Performance Curves 60 Hz

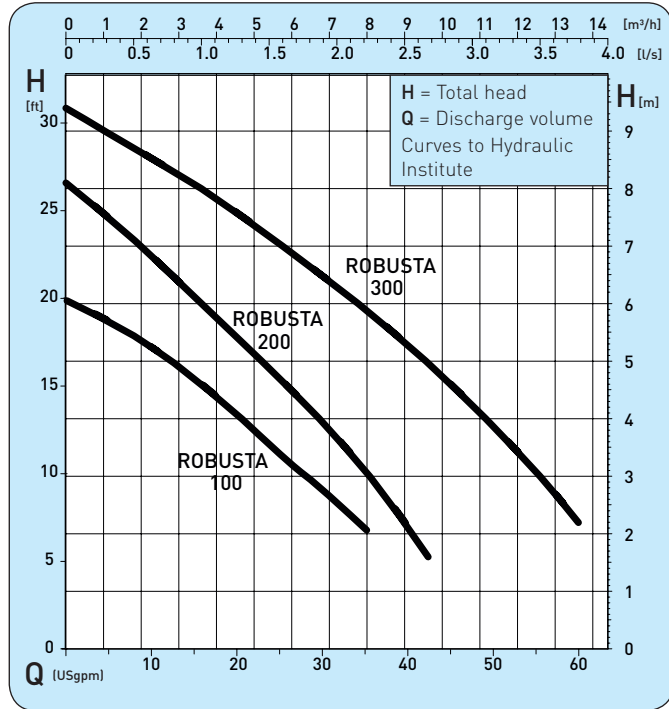

Dimensions

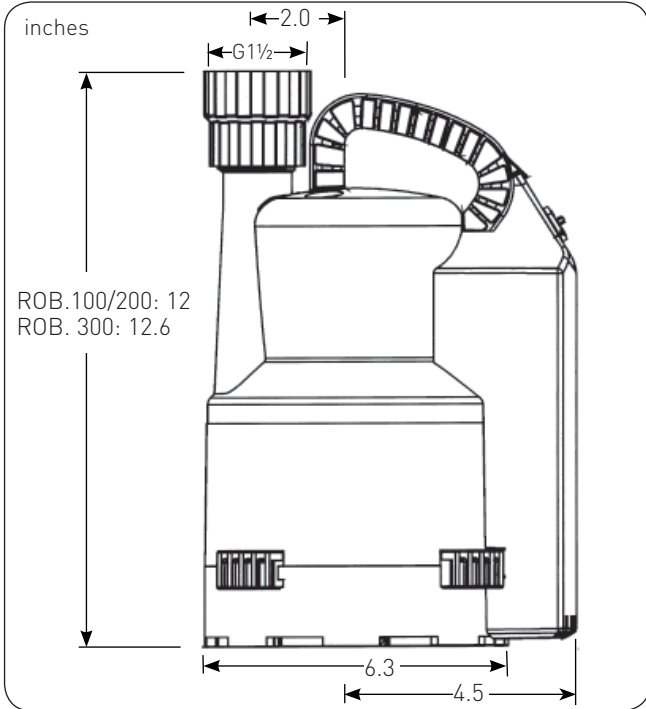

Discharge connection (standard)

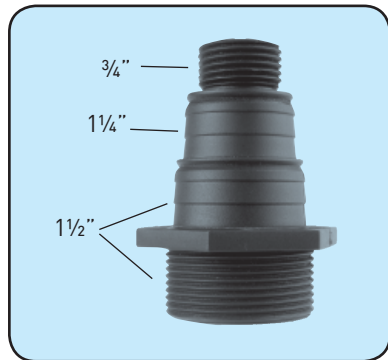

Installation Example

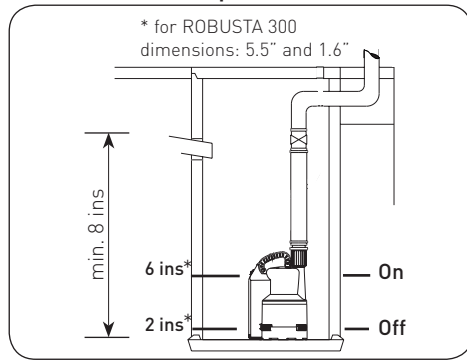

Corporate Office:
 ABS Pumps Inc.
 140 Pond View Drive
 Meriden, CT 06450
 Tel: (203) 238-2700
 Fax: (203) 238-0738

Regional Offices:
 ABS Pumps Inc.
 111 Maritime Drive
 Sanford, FL 32771
 Tel: (407) 330-3456
 Fax: (407) 330-3404

Odell's Pump & Motor Service
 1650 Bell Avenue, Suite 140
 Sacramento, CA 95838
 Tel: (916) 925-8508
 Fax: (916) 925-3914

C H & E Pumps
 3849 N. Palmer St.
 Milwaukee, WI 53212
 Tel: (414) 964-3400
 Fax: (414) 964-0677

ABS Pumps Corp.
 1215 Meyerside Drive, Unit #7
 Mississauga, ONT L5T 1H3
 Tel: (905) 670-4677
 Fax: (905) 670-3709

