

MECHANICAL PACKING AND GASKET CATALOG

ENVIRONMENTALLY FRIENDLY
SEALING SOLUTIONS





TABLE OF CONTENTS

OVERVIEW

ROTATING EQUIPMENT SEALING

Application Specific

1740 Anti Extrusion Aramid.....	7
1730SC Silicone Core.....	8
1765 White ePTFE Chemical.....	9
1830-SSP PTFE/Graphite.....	10
1725A High Performance Food Grade.....	11
329 Stern-Lon Flax.....	12
370 Lubricated Carbon.....	13
425 Food Grade.....	14
477-1T Carbon/PTFE.....	15
DigesterPak™ Carbon Reinforced PTFE/Graphite.....	16
Two High Speed Graphite.....	17

Plantwide Packing

1760 PTFE/Graphite.....	18
1830 Graphite/PTFE.....	19
Innerlube™ Synthetic/PTFE.....	20
1727 Multi-Lon®.....	21
Mill Pack 1730™.....	22
412-W Multi-Service.....	23

Injectables

CMS 2000 Flushless Packing System.....	24-25
--	-------

SuperSet™

SuperSet featuring SprialTrac™.....	26-27
-------------------------------------	-------

MULTI PURPOSE SEALING

1400R Carbon Reinforced Graphite Tape.....	29
477-1 Carbon Fiber.....	30
GraphMax™ Structurally Reinforced Graphite.....	31

VALVE SEALING

Bonnet Seals

5900 Graphite.....	33
--------------------	----

High Performance

1724E Control Valve Kits.....	34-35
5800 WedgeSeal™.....	36
5800E Emissions WedgeSeal™.....	37
5800E Emissions Control Valve Kits.....	38-39
5800T Low Friction WedgeSeal™.....	40-41
5800T Low Friction Control Valve Kits.....	42
Valve Sealing System.....	44-45
5150 Live Loading Assembly.....	45
5150 Valve Cartridge Live Loading.....	45
One-CI Braided Graphite Rings.....	45
5300 (GTPI) Die-Formed Inhibited Graphite Rings.....	45
5100 Carbon Sleeve.....	45

Braided

1600 Reinforced Graphite Tape.....	46
1601 Reinforced Graphite Tape.....	47
1622 Low Emissions Graphite Tape.....	48
1724 Non Hardening PTFE Yarn.....	49
324 Non Hardening PTFE Yarn.....	50
401 Wire Reinforced Braided Yarn.....	51
1400R Carbon Reinforced Graphite Tape.....	29
477-1 Carbon Fiber.....	30
GraphMax™ Structurally Reinforced Graphite.....	31

FLANGE SEALING

Live Loading

Flange Discs.....	53
5500.....	53
5505L.....	53
5505H.....	53

Semi-Metallic Gaskets

Steel Trap™.....	54
Spiral Wound.....	54
Camprofile.....	55

Sheet/Soft Gaskets

100 Red Rubber.....	56
119 Cloth Inserted Rubber.....	56
122NN Diaphragm.....	57
124 Oil Resistant Rubber.....	57
184 Expanded PTFE.....	58
195 Synthetic Fiber.....	58
198 Inhibited Graphite.....	59
199 Foil Inserted Inhibited Graphite.....	59
359 Graphite.....	60
450 Synthetic Fiber.....	60
455 Aramid Fiber.....	61
457 Carbon Fiber.....	61
459 Graphite.....	62
553 Environmental Sheet.....	62
Environmental Containment Sheet (ECS).....	63
ECS-W (White).....	63
ECS-T (Tan).....	63
ECS-B (Blue).....	63

Tape Gaskets

165 Graphite Joint Sealant.....	64
175 Silicon Foam.....	64
185 Expanded PTFE Joint Sealant.....	65
160 Fiberglass Tape.....	66
161 Fiberglass Rope.....	66
162 Fiberglass Cloth.....	67
289 Fiberglass Tape.....	67

SPECIALTY EQUIPMENT

Tank Covers, Hatches, and Lids

Lid Lock PTFE Based.....	69
--------------------------	----

Sootblower Seals

3000 Sootblower Sets.....	70-71
5700/5700B Sootblower Kits.....	72

TOOLS

179 Gasket Cutter and Accessories.....	75
174 Packing Knife.....	75
178 Ring Packing Cutter.....	75
176 Tamping Tools.....	75
242 Stiff Packing Extractors.....	76
253 Flex Packing Extractors.....	76
Water Jet Packing Extractor.....	76
Sure-Cut Packing Cutter.....	76

PRODUCTS BY INDUSTRY

Products by Industry.....	
Listed Alphabetically.....	77-81

CHESTERTON®

Providing value to industry since 1884

A.W. Chesterton Company is a leading international manufacturer and distributor of five distinct product lines. Each product line is positioned to provide value-driven solutions to meet industry needs.

Since 1884 we have worked closely with our customers to provide solutions that help them operate more reliably, efficiently, and economically.

A.W. Chesterton Company is ISO 9001/14001, and MRP II Class-A certified.

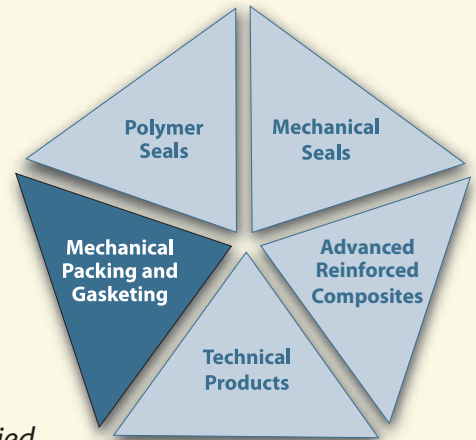

Global Solutions

Chesterton has been providing value-driven solutions around the globe, with documented success and recognition, by using high performance materials and designs to solve your toughest sealing needs.

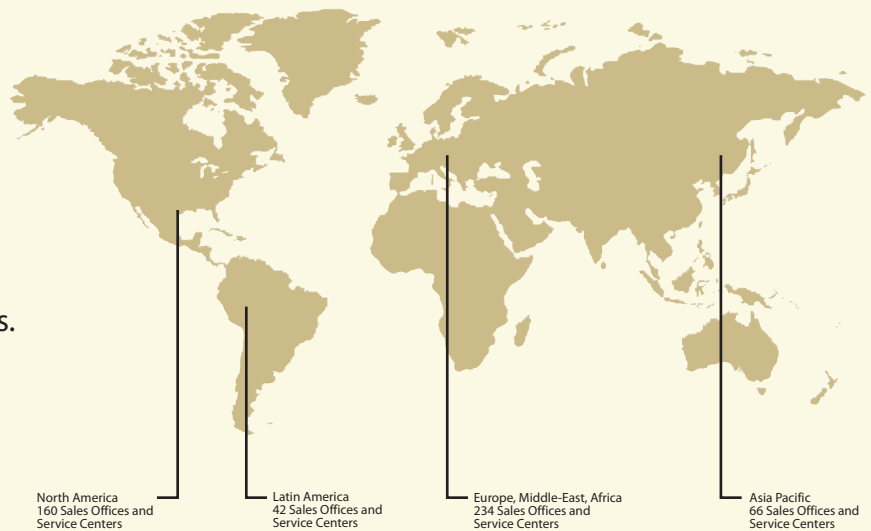

Local Service

The expertise of your local Chesterton Technical Specialist and the support of our engineering staff will enable you to significantly reduce operating costs, increase reliability, and realize years of trouble-free service.

MECHANICAL PACKING AND GASKET SOLUTIONS

Chesterton is a worldwide manufacturer and distributor of high performing sealing devices including pump and valve packings, pump sealants, live loading technology, sheet gaskets, joint sealants, and semi-metallic gaskets for a wide range of applications.

Although packing and gaskets are considered by some to be technologies of the past, we continuously research and advance the state-of-the-art for packing and gaskets.

Our advanced packings provide such benefits as substantial water reduction, superior leakage and emissions control, the ability to operate at high pressures and speeds, and resistance to process chemicals, and the reduction of sleeve and stem scoring.

Our sheet gaskets features high stability and reinforced synthetics that provide excellent sealability and superior reliability.

Our joint sealants provide long lasting, high reliability sealing and are fast and easy to use.

Chesterton Live Loading technology has become the worldwide standard for long term, low emissions, low maintenance packing. We were the first company to successfully apply Live Loading and have the most experience as the world's largest bank of Live Loaded valves.

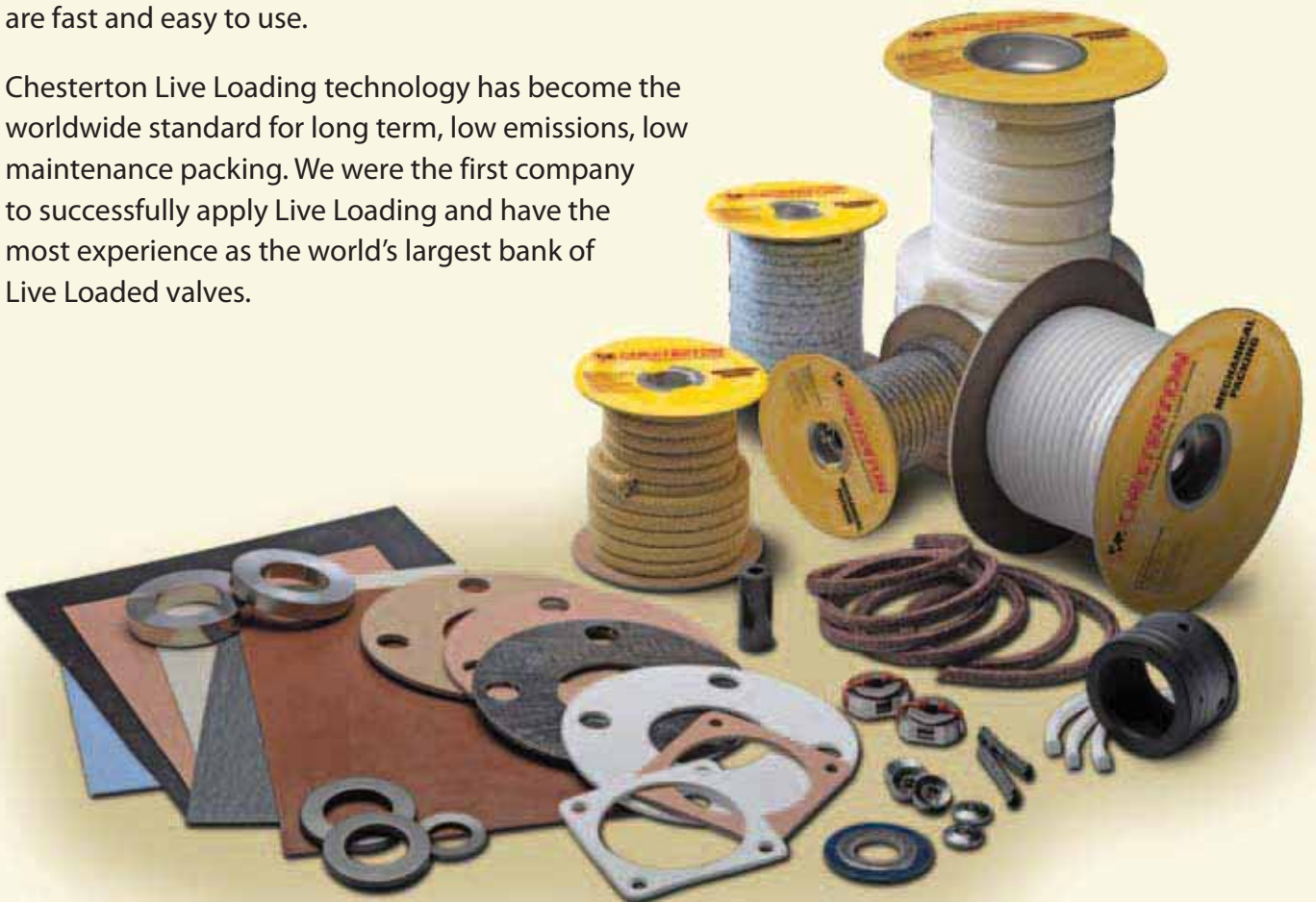

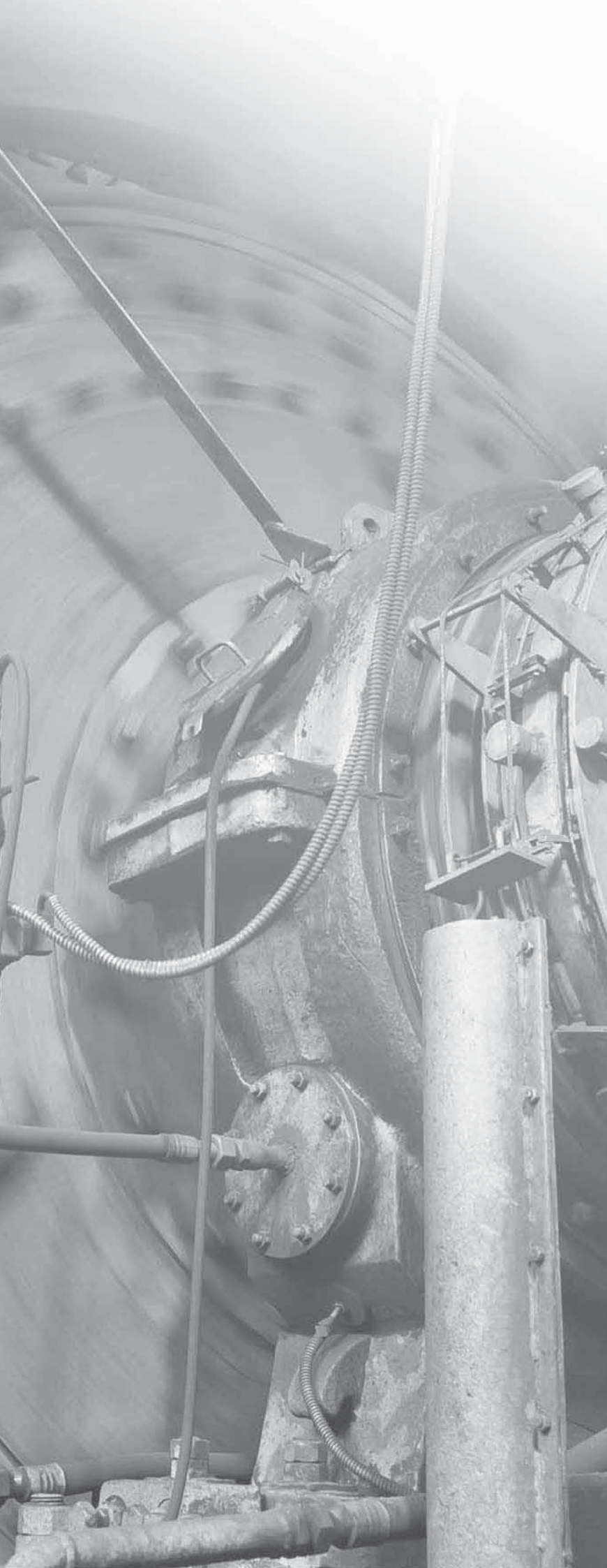

ROTATING EQUIPMENT SEALING

- Application specific
- Plantwide packing
- Injectables
- SuperSet™ and SpiralTrac™

1740

Anti Extrusion Aramid

Chesterton 1740 is an interbraid packing using Kevlar® yarn and lubricated with PTFE and other lubricants. Each strand of yarn has been individually coated in order to dissipate heat. 1740 can be installed as full sets to offer combined resistance to pressure, temperature, chemicals, and wear. 1740 is also used as back-up rings for added extrusion resistance in abrasive applications.

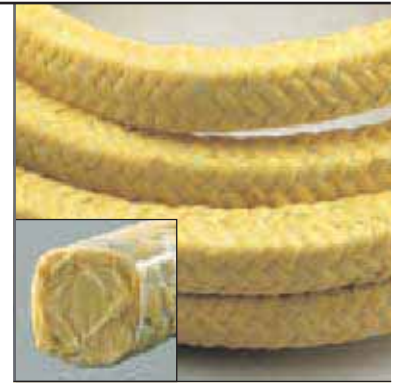

Product Reorder				
Size		Packaged ± 10%		Reorder Number
mm	Inch	kg	lbs	
3,0	1/8	0,908	2	004360
4,0	–	0,908	2	004361
5,0	3/16	0,908	2	004362
6,0	–	0,908	2	004363
6,5	1/4	0,908	2	004364
		2,270	5	004373
8,0	5/16	0,908	2	004365
		2,270	5	004374
9,5	3/8	0,908	2	004366
		2,270	5	004375
		4,540	10	004381
10,0	–	0,908	2	004367
		2,270	5	004376
11,0	7/16	2,270	5	004377
12,0	–	0,908	2	004369
		2,270	5	004378
12,5	1/2	0,908	2	004370
		2,270	5	004379
		4,540	10	004383
14,0	9/16	2,270	5	004380
16,0	5/8	4,540	10	004385
17,5	11/16	4,540	10	004386
19,0	3/4	4,540	10	004387
20,5	13/16	4,540	10	004388
22,0	7/8	4,540	10	004389
24,0	15/16	4,540	10	004393
25,5	1	4,540	10	004394

- Excellent extrusion resistance in abrasive applications
- Non-staining, non-contaminating
- Non-asbestos, multi-service packing

Technical Data

Temperature Limit:
260°C (500°F)

Pressure Limit:
20 bar g (300 psig)

Shaft Speed:
10 m/s (2000 fpm)

Chemical Resistance:
pH 4 to 11

Applications:
Shafts, rods, valves, expansion joints against water, steam, solvents, mild acids, alkalies, and oils

1730SC

Silicone Core

Chesterton 1730SC combines a resilient silicone rubber core with the heat resistant, thermoset fiber of Chesterton’s MillPack 1730™. The elastic rubber core gives the packing better memory, allowing it to withstand radial shaft motion and vibration while maintaining excellent leakage control with minimal gland adjustments. Rugged, easy to use and break-in, the 1730SC is designed for use in general service applications such as agitators, blenders, mixers, or any other applications that undergo shaft deflection in normal operating conditions.



- Rugged, easy to use general service packing
- Withstands radial shaft motion and vibration

Technical Data

Temperature Limit:
230°C (450°F)

Shaft Speed:
10 m/s (2000 fpm)

Chemical Resistance:
pH 2 to 12

Applications:
Agitators, mixers, blenders, washers, and pulpers

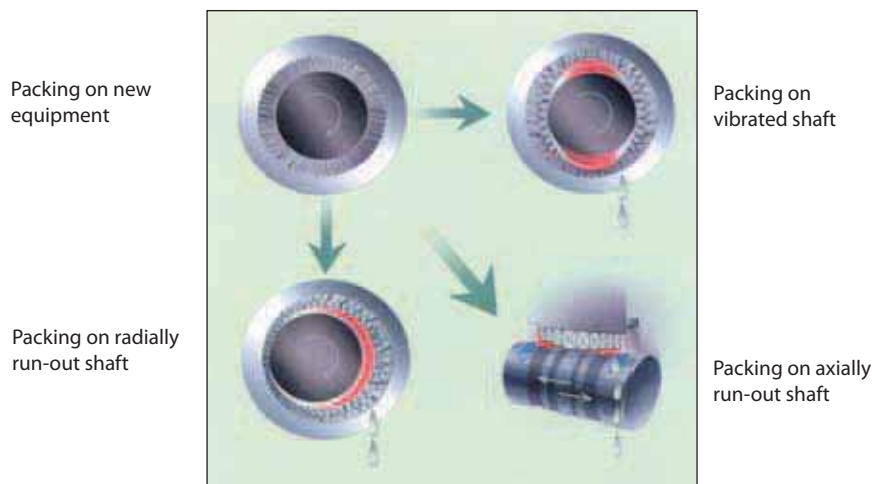

Product Reorder				
Size		Packaged ± 5%		Reorder Number
mm	Inch	kg	lbs	
9,5	3/8	2,270	5	003437
		4,540	10	003576
10,0	-	0,908	2	003577
		2,270	5	003601
11,0	7/16	2,270	5	003659
12,0	-	0,908	2	003660
		2,270	5	003661
12,5	1/2	2,270	5	003897
		4,540	10	003983
14,0	9/16	2,270	5	003984
		4,540	10	003985
16,0	5/8	4,540	10	003986
17,5	11/16	4,540	10	004059
19,0	3/4	4,540	10	004255
20,5	13/16	4,540	10	004256
22,0	7/8	4,540	10	004272
25,5	1	4,540	10	004276

NOTE: Please contact Customer Service or your Chesterton Technical Sales Specialist for Available Sizes

1765

White ePTFE Chemical

Chesterton 1765 is ideally suited for bleach pumps and other rotary applications requiring a white, non-staining packing. Constructed from chemically-resistant, expanded PTFE material, 1765 demonstrates higher speed performance capabilities than traditional PTFE materials, for improved performance in a wide range of applications. The 1765 packing is designed to maintain process media integrity while controlling corrosive leakage.



Product Reorder				
Size		Packaged ± 10%		Reorder Number
mm	Inch	kg	lbs	
6,5	1/4	0,908	2	051172
		2,270	5	051173
8,0	5/16	0,908	2	051174
		2,270	5	051175
9,5	3/8	0,908	2	051176
		2,270	5	051177
10,0	-	0,908	2	051178
		2,270	5	051179
11,0	7/16	2,270	5	051180
12,0	-	2,270	5	051181
12,5	1/2	0,908	2	051182
		2,270	5	051183
		4,540	10	051184
14,0	9/16	2,270	5	051185
16,0	5/8	4,540	10	051186
19,0	3/4	4,540	10	051187
20,5	13/16	4,540	10	051188
22,0	7/8	4,540	10	051189
25,5	1	4,540	10	051190

- Improved resiliency and reduced cold flow material properties
- Dense, interbraided construction
- Higher pressure and speed capabilities with high corrosion resistance
- Low friction and improved heat dissipation properties

Technical Data

Temperature Limit:

-40°C (-40°F) minimum
260°C (500°F) maximum

Pressure Limit:

20 bar g (300 psig)

Shaft Speed:

10 m/s (2000 fpm)

Chemical Resistance:

pH 0 to 14 except for Fluorine (F₂), ClF₃ and related compounds, molten and alkali metals

Applications:

Centrifugal pumps, inline mixers, reciprocating rods and agitators

1830-SSP

PTFE/Graphite

Chesterton 1830-SSP Slurry Sealing Packing is manufactured with a hybrid yarn combining advanced, expanded graphite PTFE yarn with carbon yarn reinforcement. This unique construction of yarns yields a packing that is easily removable during repack resulting in reduced downtime. 1830-SSP is applicable in a wide range of slurry sealing applications.



Product Reorder				
Size		Packaged ± 10%		Reorder Number
mm	Inch	kg	lbs	
9,5	3/8	0,908	2	052605
		2,270	5	052606
		4,540	10	052607
10,0	–	0,908	2	052608
		2,270	5	052609
11,0	7/16	0,908	2	052610
		2,270	5	052611
12,0	–	0,908	2	052612
		2,270	5	052613
12,5	1/2	0,908	2	052614
		2,270	5	052615
		4,540	10	052616
14,0	9/16	2,270	5	052617
		4,540	10	052618
16,0	5/8	4,540	10	052619
17,5	11/16	4,540	10	052620
19,0	3/4	4,540	10	052621
20,0	–	4,540	10	052622
20,5	13/16		To Order	
22,0	7/8	4,540	10	052624
24,0	15/16	4,540	10	052625
25,5	1	4,540	10	052626

- Developed to meet rigid demands of slurry sealing applications
- Low friction, less heat generation, non-abrasive, saves shafts and shaft sleeves
- Low leakage and long life

Technical Data

Temperature Limit:
260°C (500°F)

Pressure Limit:
28 bar g (400 psig)

Shaft Speed:
18 m/s (3600 fpm)

Chemical Resistance:
pH 0 to 14 except with strong oxidizers in the 0 to 2 pH range

Applications:
Bauxite slurries, bottom ash slurry pumps, mineral handling slurries, tailings pumps and other slurry processing applications

1725A

High Performance Food Grade

Chesterton 1725A is a white, non-staining, ePTFE packing for use in Food Processing equipment including pumps, agitators and mixers.

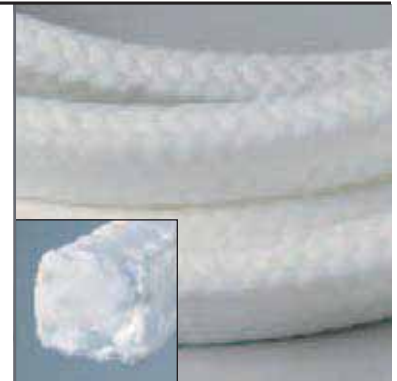

Product Reorder				
Size		Packaged ± 10%		Reorder Number
mm	Inch	kg	lbs	
6,5	1/4	2	0,908	041020
		5	2,270	041027
8,0	5/16	2	0,908	041029
		5	2,270	041030
9,5	3/8	2	0,908	041031
		5	2,270	041033
10,0	-	2	0,908	041038
		5	2,270	041044
11,0	7/16	5	2,270	041046
12,0	-	5	2,270	041048
12,5	1/2	2	0,908	041049
		5	2,270	041050
		10	4,540	041051
14,0	9/16	5	2,270	041052
16,0	5/8	10	4,540	041053
19,0	3/4	10	4,540	041074
20,5	13/16	10	4,540	041075
22,0	7/8	10	4,540	041076
25,5	1	10	4,540	041078

- Meets USDA Requirements for minimal food contact
- Meets FDA Requirements 21 CFR 178.3297, 21 CFR 177.2800, 21 CFR 177.1550
- Completely inert to most materials
- Handles high shaft speeds

Technical Data

Temperature Limit:
260°C (500°F)

Pressure Limit:
22 bar g (325 psig)

Shaft Speed:
9 m/s (1800 fpm)

Chemical Resistance:
pH 0 to 14

Applications:
Chemical and food grade rotating equipment except for strong oxidizers and molten alkali metals

329

Stern-Lon Flax

Chesterton 329 is square plait braided to provide an unusually flexible, formable packing. The base fiber in Stern-Lon is a long-fibered, roved flax of the highest quality. The packing is graphite free to avoid galvanic corrosion on shafts. 329 is first impregnated with concentrated PTFE dispersion to promote non-flowing lubricity and to retard degradation. This is followed with a plasticizing “break-in” lubricant which assures compressibility, flexibility, and good packing-to-shaft contact. Large sizes need not be hammered into place. Finally, in order to minimize frictional attrition, a finely divided fluorocarbon powder is embedded into the surface of the packing. 329 produces little or no shaft or sleeve wear.

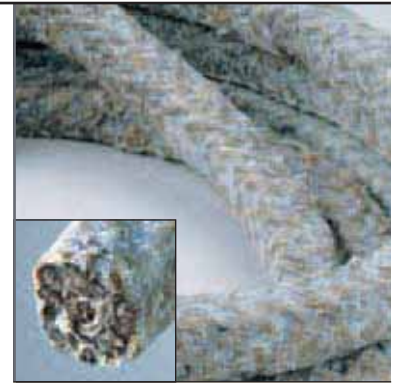

- Suitable for stern tube and paper mill packing
- Most recognized product for the marine industry in Stern Tubes

Product Reorder				
Size		Packaged ± 10%		Reorder Number
mm	Inch	kg	lbs	
6,5	1/4	2,270	5	032973
8,0	5/16	2,270	5	032974
9,5	3/8	2,270	5	032975
		4,540	10	032981
11,0	7/16	2,270	5	032977
12,5	1/2	2,270	5	032979
		4,540	10	032983
14,0	9/16	2,270	5	032980
		4,540	10	032984
16,0	5/8	4,540	10	032985
17,5	11/16	4,540	10	032986
19,0	3/4	4,540	10	032987
20,5	13/16	4,540	10	032988
22,0	7/8	4,540	10	032989
24,0	15/16	4,540	10	032993
25,5	1	4,540	10	032994

Technical Data

Temperature Limit:
135°C (275°F)

Pressure Limit:
20 bar g (300 psig)

Shaft Speed:
5 m/s (1000 fpm)

Chemical Resistance:
pH 6 to 8

Applications:

Marine

Stern tubes, rudder posts, shaft bulkhead glands, and cold water

Pulp and Paper

Jordans, clafins, hydro-finers

370

Lubricated Carbon

Unique carbon and graphite construction provides plantwide utility off a single spool. Chesterton 370 is manufactured from a high quality carbon yarn. 370 incorporates particles of pure graphite, high-temperature oils, and molybdenum disulfide which act as long-life lubricants and blocking agents. The low-friction carbon yarn has exceptional high-temperature capability in a non-oxidizing environment.

Product Reorder				
Size		Packaged ± 10%		Reorder Number
mm	Inch	kg	lbs	
3,0	1/8	0,908	2	037060
5,0	3/16	0,908	2	037062
6,0	–	0,908	2	037063
6,5	1/4	0,908	2	037064
		2,270	5	037073
8,0	5/16	0,908	2	037065
		2,270	5	037074
9,5	3/8	0,908	2	037066
		2,270	5	037075
		4,540	10	037081
10,0	–	0,908	2	037067
		2,270	5	037076
11,0	7/16	0,908	2	037068
		2,270	5	037077
12,0	–	2,270	5	037078
12,5	1/2	0,908	2	037070
		2,270	5	037079
		4,540	10	037083
14,0	9/16	2,270	5	037080
16,0	5/8	4,540	10	037085
17,5	11/16	4,540	10	037086
19,0	3/4	4,540	10	037087
22,0	7/8	4,540	10	037089
25,5	1	4,540	10	037094
38,0	1-1/2	4,540	10	037022



- Best choice for high temperature
- Fast break-in, few adjustments, controlled leakage, and long life
- Multi-service permits plant-wide standardization, reduces inventory requirements
- Low leachable chloride content for applications and industries where halogen content is restricted, such as nuclear,* petrochemical, and fossil fuel plants
- Interbraid construction with 4-stage lubrication controls leakage with minimal friction, allows turning off flush in many applications
- Reduced leakage and flushing, cuts costs associated with housekeeping, sewage treatment, product dilution, and evaporation losses

Technical Data

Temperature Limit:
315°C (600°F) steam

Pressure Limit:
35 bar g (500 psig)

Shaft Speed:
18 m/s (3600 fpm)

Chemical Resistance:
pH 0 to 14 except oleum, fuming nitric acid, aqua regia and fluorine

Applications:
Pulpers, stock pumps, agitators, fan pumps, vacuum pumps, condensate pumps, screw feeders, refiners

*Can be certified to less than 200 ppm leachable chloride. Consult factory for specific chemical assay.

425

Food Grade

Chesterton 425 is manufactured with a virgin PTFE filament and a white oil lubricant. It is perfectly suited for use in valves and also in rotating equipment such as blenders, mixers, agitators, and other rotating equipment. Chesterton 425 complies with the USDA requirements for minimal food contact and FDA specification 21 CFR, 178.3620(a) for lubricants with incidental food contact as well as 177.1550 perfluorocarbon resins.



Product Reorder				
Size		Packaged ± 10%		Reorder Number
mm	Inch	kg	lbs	
5,0	3/16	0,908	2	042514
6,5	1/4	0,908	2	042515
		2,270	5	042516
8,0	5/16	0,908	2	042517
		2,270	5	042518
9,5	3/8	0,908	2	042519
		2,270	5	042520
10,0	-	0,908	2	042550
		2,270	5	042551
11,0	7/16	2,270	5	042552
12,0	-	To Order		
12,5	1/2	0,908	2	042553
		2,270	5	042554
		4,540	10	042555
14,0	9/16	2,270	5	042556
16,0	5/8	4,540	10	042557
19,0	3/4	4,540	10	042558
22,0	7/8	4,540	10	042559
25,5	1	To Order		

- Meets USDA requirements
- Meets FDA requirements 21 CFR 178.3620(a) and 21 CFR 177.1550
- For use in valves, pumps, and other rotating and reciprocating equipment

Technical Data

Temperature Limit:
230°C (450°F)

Shaft Speed:
6 m/s (1200 fpm)

Chemical Resistance:
pH 0 to 14

Applications:
All types of equipment in the food processing and handling industry, such as valves, cookers, blenders, agitators, pumps, and mixers

477-1T

Carbon/PTFE

Chesterton 477-1T is a tough, yet pliable, continuous filament carbon yarn packing impregnated throughout with PTFE to provide a non-contaminating, non-staining carbon yarn packing. 477-1T was developed for tough applications in the pulp and paper industry. It is specially designed to be used in **high pressure feeders, pre-steaming vessels** and applications that are moving abrasive slurries. The combination of carbon yarn and PTFE dispersions increases the 477-1T chemical resistant properties when up against strong caustic and acid mediums.

477-1T is also an excellent bottom anti-extrusion end ring in combination with 1400R in rotating equipment. This combination is ideal when attempting to reduce or eliminate flush water from a stuffing box.

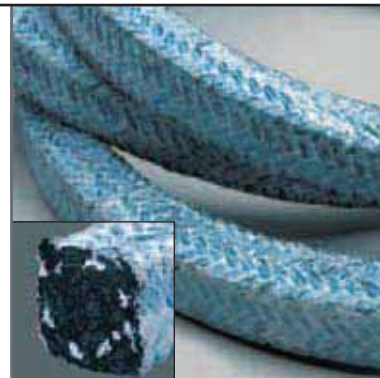

- Non-contaminating, non-staining carbon yarn packing
- Unique inorganic blocking agent stops gas/liquid penetration
- Molybdenum-based corrosion inhibitor prevents stem pitting

Product Reorder				
Size		Packaged ± 10%		Reorder Number
mm	Inch	kg	lbs	
3,0	1/8	0,908	2	004346
5,0	3/16	0,908	2	004348
6,0	–	0,908	2	004349
6,5	1/4	0,908	2	004350
		2,270	5	004351
8,0	5/16	0,908	2	004352
		2,270	5	004353
9,5	3/8	0,908	2	004354
		2,270	5	004355
		4,540	10	004356
10,0	–	0,908	2	004357
		2,270	5	004358
11,0	7/16	0,908	2	004359
		2,270	5	004392
12,0	–	0,908	2	004395
		2,270	5	004396
12,5	1/2	0,908	2	004397
		2,270	5	004399
		4,540	10	004413
14,0	9/16	2,270	5	004415
		4,540	10	004417
16,0	5/8	4,540	10	004418
17,5	11/16	4,540	10	004446
19,0	3/4	4,540	10	004447
20,5	13/16	4,540	10	004448
22,0	7/8	4,540	10	004449
24,0	15/16	4,540	10	004450
25,5	1	4,540	10	004451

Technical Data

Temperature Limit:
260°C (500°F)

Pressure Limit:
14 bar g (200 psig)

Shaft Speed:
10 m/s (2000 fpm)
15 m/s (3000 fpm) when used as a bottom anti-extrusion ring with 1400R

Chemical Resistance:
pH 0 to 14 except with strong oxidizers

Applications:
Pulp and paper, pre-steaming vessels, high and low pressure feeders, grinding stone, hydropulpers, agitators and mixers

DigesterPak™

Carbon Reinforced PTFE/Graphite

Chesterton DigesterPak is specifically designed for sealing tough equipment in the digester area. It combines graphite coated PTFE braided packing with carbon reinforcement to provide outstanding resilience, superior leakage control, and long term sealing. DigesterPak brings you a reliable, heavy-duty packing set for all digester area sealing on new and old equipment. DigesterPak can be combined with Chesterton's other high performance braided packing for best performance in the most demanding applications. See the Digester Application Guide, Form Number 088146 for specific configurations.



- Reliable, high performance digester packing
- Long-term sealing
- Superior leakage control
- For all digester area sealing needs

Technical Data

Temperature Limit:
260°C (500°F)

Shaft Speed:
18 m/s (3600 fpm)

Chemical Resistance:
pH 0 to 14 except with strong oxidizers in the 0 to 2 pH range

Applications:
Chip meter, LP feeder, HP feeder, impregnation vessel top separator, pulp distributor, digester top separator, and outlet device

Product Reorder				
Size		Packaged ± 10%		Reorder Number
mm	Inch	kg	lbs	
12,5	1/2	2,270	5	087501
		4,540	10	087502
16,0	5/8	4,540	10	087506
19,0	3/4	6,804	15	087510
		11,340	25	087524
20,0	-	6,804	15	087514
		11,340	25	087525
20,5	13/16	6,804	15	087517
		11,340	25	087526
22,0	7/8	6,804	15	087519
		11,340	25	087527
24,0	15/16	6,804	15	087521
		11,340	25	087528
25,5	1	6,804	15	087523
		11,340	25	087529

Two

High Speed Graphite

Chesterton Two high speed graphite packing is manufactured from a pure quality graphite yarn braided in interbraid construction, then treated with special, high temperature, break-in lubricants. The special sacrificial multi-temperature lubricants are used to ease break-in and quickly effect a satisfactory leakage rate. Once the break-in lubricants are sacrificed, the remaining super-graphite product has the chemical resistance to withstand virtually all chemicals. The highest conductivity of this packing combined with the automatic self-lubricating properties allow use with virtually no shaft scoring.



- Maximum performance universal pump and valve packing
- Self-lubricating, virtually no shaft scoring
- Non-hardening, non-glazing

Product Reorder				
Size		Packaged ± 10%		Reorder Number
mm	Inch	kg	lbs	
6,5	1/4	0,908	2	037754
		2,270	5	037704
8,0	5/16	0,908	2	037755
		2,270	5	037705
9,5	3/8	0,908	2	037756
		2,270	5	037706
11,0	7/16	2,270	5	037707
12,5	1/2	0,908	2	037758
		3,178	7	037708
14,0	9/16	3,178	7	037709
16,0	5/8	3,178	7	037710
17,5	11/16	3,178	7	037711
19,0	3/4	3,178	7	037712
22,0	7/8	To Order		037714
25,5	1	To Order		037716

Technical Data

Temperature Limit:
 2760°C (5000°F) non-oxidizing
 425°C (800°F) oxidizing

Shaft Speed:
 23 m/s (4500 fpm)

Chemical Resistance:
 pH 0 to 14 except oleum, fuming nitric acid, aqua regia, and fluorine

Applications:
 Virtually all pumps and valves against most solvents, gases, and other liquids

1760

PTFE/Graphite

Chesterton 1760 is a unique packing consisting of a PTFE yarn lubricated with graphite particles. The finished packing is further lubricated with a special silicone oil for quick break-in.



Product Reorder				
Size		Packaged ± 10%		Reorder Number
mm	Inch	kg	lbs	
3,0	1/8	0,908	2	008360
5,0	3/16	0,908	2	008362
6,0	–	0,908	2	008363
6,5	1/4	0,908	2	008364
		2,270	5	008373
8,0	5/16	0,908	2	008365
		2,270	5	008374
9,5	3/8	0,908	2	008366
		2,270	5	008375
		4,540	10	008381
10,0	–	0,908	2	008367
		2,270	5	008376
11,0	7/16	0,908	2	008368
		2,270	5	008377
12,0	–	0,908	2	008369
		2,270	5	008378
12,5	1/2	0,908	2	008370
		2,270	5	008379
		4,540	10	008383
14,0	9/16	2,270	5	008380
16,0	5/8	4,540	10	008385
17,5	11/16	4,540	10	008386
19,0	3/4	4,540	10	008387
20,5	13/16	4,540	10	008388
22,0	7/8	4,540	10	008389
25,5	1	4,540	10	008394

- Superior leakage control throughout the plant
- Low friction, higher shaft speed
- Non-abrasive, less wear, longer life
- Higher chemical resistance for plantwide use

Technical Data

Temperature Limit:
260°C (500°F)

Shaft Speed:
18 m/s (3600 fpm)

Chemical Resistance:
pH 0 to 14

Applications:
Centrifugal pumps, reciprocating rods, and agitators

1830

Graphite/PTFE

Chesterton 1830 is an advanced expanded graphite PTFE packing made up of filaments developed to meet rigid specifications. Use in pumps, valves, agitators, mixers, and other rotating equipment. PTFE resin is combined with graphite and expanded by using the latest technologies, resulting in a high-quality filament.



Product Reorder				
Size		Packaged ± 10%		Reorder Number
mm	Inch	kg	lbs	
5,0	3/16	0,908	2	175910
6,5	1/4	0,908	2	175911
		2,270	5	175912
8,0	5/16	0,908	2	175913
		2,270	5	175914
9,5	3/8	0,908	2	175915
		2,270	5	175916
		4,540	10	175917
10,0	-	0,908	2	175918
		2,270	5	175919
11,0	7/16	0,908	2	175920
		2,270	5	175921
12,0	-	0,908	2	175922
		2,270	5	175923
12,5	1/2	0,908	2	175924
		2,270	5	175925
		4,540	10	175926
14,0	9/16	2,270	5	175927
		4,540	10	175928
16,0	5/8	4,540	10	175929
17,5	11/16	4,540	10	175930
19,0	3/4	4,540	10	175931
20,0	-	4,540	10	175932
20,5	13/16	To Order		
22,0	7/8	4,540	10	175933
24,0	15/16	4,540	10	175934
25,5	1	4,540	10	175935

- Developed to meet rigid specifications in pumps, valves, agitators, mixers, and other rotating equipment
- Low friction, less heat generation, non-abrasive, saves shafts and shaft sleeves
- Quick to install, easy to disassemble
- Low leakage and long life
- Wide range of applications

Technical Data

Temperature Limit:
260°C (500°F)

Pressure Limit:
22 bar g (320 psig)

Shaft Speed:
18 m/s (3600 fpm)

Chemical Resistance:
pH 0 to 14 except with strong oxidizers in the 0 to 2 pH range

InnerLube™

Synthetic/PTFE

Chesterton InnerLube is a unique packing that combines Chesterton’s synthetic composite yarn and patented InnerLube construction. InnerLube is lubricated with PTFE and further coated with a specially formulated break-in lubricant. InnerLube offers increased lubrication at start-up and continues to disperse lubrication during operation, resulting in lower operating temperatures and reduced shaft and sleeve wear. InnerLube’s construction incorporates lubricant reservoirs within the braided structure. Standard packing lubricants dissipate quickly from frictional heat. The InnerLube reservoirs slowly release additional lubricant under gland pressure and increased temperature. InnerLube absorbs twice the amount of blocking agents as conventional packings for better leakage control and superior life.



- Patented advanced pump packing
- Increased lubrication
- Lower operating temperatures
- Non-staining, chemically resistant

Product Reorder				
Size		Packaged ± 10%		Reorder Number
mm	Inch	kg	lbs	
6,5	1/4	0,908	2	035603
		2,270	5	035604
8,0	5/16	0,908	2	035605
		2,270	5	035606
9,5	3/8	2,270	5	035607
		4,540	10	035608
10,0	–	0,908	2	035609
		2,270	5	035610
11,0	7/16	2,270	5	035611
12,0	–	0,908	2	035612
		2,270	5	035613
12,5	1/2	2,270	5	035614
		4,540	10	035615
14,0	9/16	2,270	5	035616
		4,540	10	035617
16,0	5/8	4,540	10	035618
17,5	11/16	4,540	10	035619
19,0	3/4	4,540	10	035620
20,5	13/16	4,540	10	035621
22,0	7/8	4,540	10	035622
24,0	15/16	4,540	10	035623
25,5	1	4,540	10	035624

Technical Data

Temperature Limit:
260°C (500°F)

Shaft Speed:
10 m/s (2000 fpm)

Chemical Resistance:
pH 2 to 12

Applications:

Paper mills
Stock pumps, hydropulpers, and refiners

Waste water and sewage plants
Slurries, water

Marine services
Water and brine pumps

Mining
Dewatering pumps, river water applications, power plants, mixers, agitators, slurry pumps

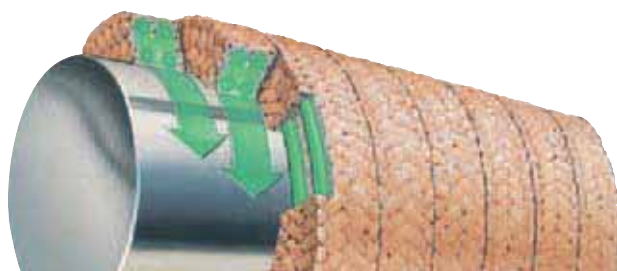

Green color is used for illustration purposes only. Lubricant is clear and non-staining.

1727

Multi-Lon®

Multi-Lon is a synthetic pump packing unique to Chesterton, designed specifically for general service pump applications. It is able to deliver performance equal to synthetics, but with the pliability of asbestos. Unlike the first generation of synthetic packings Multi-Lon does not suffer from limitations that prevent general service use. It does not cause severe scoring like many synthetic yarns, does not cause electrolytic pitting like carbon or graphite yarns, and does not have the shaft speed limitations or the elongation/extrusion problems often associated with PTFE fiber yarns. Multi-Lon consists of interbraided continuous synthetic thermoset fibers, immunized with PTFE lubricant and a special silicone free break-in, sacrificial lubricant.



- A superior general service pump packing with high chemical resistance
- All the best features of your favorite process packing combined in a single product
- Greater flexibility, less leakage
- Long wearing, fewer repacks
- Non-staining, protects product quality
- Non-hardening, fewer adjustments
- Non-abrasive, less sleeve wear
- Non-pitting, saves shafts

Product Reorder				
Size		Packaged ± 10%		Reorder Number
mm	Inch	kg	lbs	
3,0	1/8	0,908	2	009260
4,0	–	0,908	2	009261
5,0	3/16	0,908	2	009262
6,0	–	0,908	2	009263
6,5	1/4	0,908	2	009264
		2,270	5	009273
8,0	5/16	0,908	2	009265
		2,270	5	009274
9,5	3/8	2,270	5	009275
		4,540	10	009281
10,0	–	0,908	2	009267
		2,270	5	009276
11,0	7/16	2,270	5	009277
12,0	–	0,908	2	009269
		2,270	5	009278
12,5	1/2	2,270	5	009279
		4,540	10	009283
14,0	9/16	2,270	5	009280
		4,540	10	009284
16,0	5/8	4,540	10	009285
17,5	11/16	4,540	10	009286
19,0	3/4	4,540	10	009287
20,5	13/16	4,540	10	009288
22,0	7/8	4,540	10	009289
24,0	15/16	4,540	10	009293
25,5	1	4,540	10	009294

Technical Data

Temperature Limit:
255°C (488°F)

Pressure Limit:
15 bar g (200 psig)

Shaft Speed:
10 m/s (2000 fpm)

Chemical Resistance:
pH 1 to 13

Virtually unaffected by non-oxidizing acids, dilute bases, organic solvents

Should not be used in concentrated or hot sulfuric (> 60%), or nitric acids (> 10%), or strong bases

Applications:
Water, steam, and chemical pump applications in pulp and paper and chemical plants

The utility of asbestos The toughness of aramid fiber The low friction of carbon fiber The chemical resistance and non-staining cleanliness of PTFE fiber



1730

Mill Pack™

Chesterton 1730 Mill Pack thermoset fiber packing provides outstanding heat resistance while maintaining excellent leakage control and reduced power consumption. Rugged, easy-to-use thermoset fiber packing controls leakage effectively while it is kind to shafts. 1730 Mill Pack provides high reliability in the most demanding applications. It is resistant to heat and will not glaze like common paper mill packings—even at high shaft speeds.



Product Reorder				
Size		Packaged ± 10%		Reorder Number
mm	Inch	kg	lbs	
6,0	–	0,908	2	000637
6,5	1/4	0,908	2	000638
		2,270	5	000691
8,0	5/16	0,908	2	000692
		2,270	5	000693
9,5	3/8	2,270	5	000694
		4,540	10	000695
10,0	–	0,908	2	000696
		2,270	5	000697
11,0	7/16	2,270	5	000698
12,0	–	0,908	2	000702
		2,270	5	000703
12,5	1/2	2,270	5	000704
		4,540	10	000705
14,0	9/16	2,270	5	000706
		4,540	10	000932
16,0	5/8	4,540	10	000933
17,5	11/16	4,540	10	000934
19,0	3/4	4,540	10	000935
20,5	13/16	4,540	10	001182
22,0	7/8	4,540	10	001183
25,5	1	4,540	10	001184

- Economical alternative for general service
- Excellent leakage control with lower maintenance costs and simplified inventory
- White, non-staining like PTFE
- Significantly more rugged than PTFE fiber packing, or heavily coated PTFE packings in high speed applications
- Resists heat damage and glazing, kind to shaft sleeves
- User friendly, easy to cut and install, fast break-in
- Far less susceptible to adverse treatment at installation or in use

Technical Data

Temperature Limit:
290°C (550°F)

Shaft Speed:
10 m/s (2000 fpm)

Chemical Resistance:
pH 1 to 13

Applications:
Agitators, mixers, stock pumps, service water, white water, intensifiers

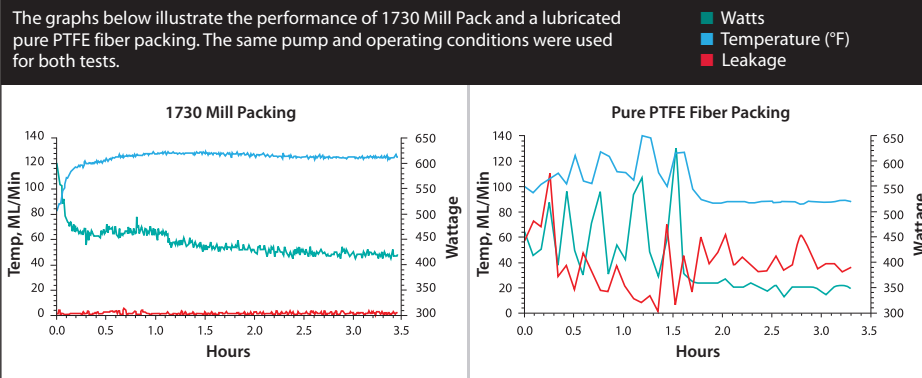

412-W

Multi-Service

Chesterton 412-W combines a newly developed synthetic composite yarn with a specially formulated break-in lubricant. Continuous filament center provides ten times the tensile strength of typical packing fibers. Fibrous covering enables 412-W to absorb twice the PTFE blocking agents of conventional packings. Chesterton interbraid construction helps prevent migration of blocking agents so that 412-W maintains density to prevent wicking throughout its service life. 412-W also incorporates a purified colloidal lubricant to prevent failure at start-up and maintain continuous lubrication throughout the break-in process.

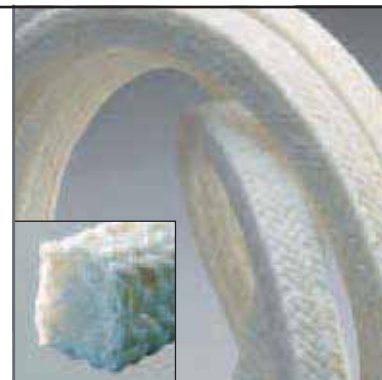

- Pure white packing constructed of exclusive ARG™ synthetic yarn
- Superior tensile strength for durability and extrusion resistance
- Unique fibrous structure holds twice the PTFE blocking agent of traditional fibers

Product Reorder				
Size		Packaged ± 10%		Reorder Number
mm	Inch	kg	lbs	
3,0	1/8	0,908	2	004127
5,0	3/16	0,908	2	004129
6,0	–	0,908	2	004131
6,5	1/4	0,908	2	004101
		2,270	5	004102
8,0	5/16	0,908	2	004105
		2,270	5	004106
9,5	3/8	2,270	5	004108
		4,540	10	004109
10,0	–	0,908	2	004133
		2,270	5	004134
11,0	7/16	2,270	5	004112
		12,0	–	0,908
2,270	5			004137
12,5	1/2	2,270	5	004114
		4,540	10	004115
14,0	9/16	2,270	5	004139
		4,540	10	004140
16,0	5/8	4,540	10	004117
17,5	11/16	4,540	10	004142
19,0	3/4	4,540	10	004119
20,5	13/16	4,540	10	004144
22,0	7/8	4,540	10	004121
24,0	15/16	4,540	10	004146
25,5	1	4,540	10	004123

Technical Data

Temperature Limit:
230°C (450°F)

Shaft Speed:
10 m/s (2000 fpm)

Chemical Resistance:
pH 4 to 10

Applications:
Mild acid and alkali services, knife gate valves due to superior conformability

Paper mills
Stock pumps

Waste water and sewage plants

Municipal water plants

Mining
Slurry applications

Marine services
Water and brine pumps

Oil field services
Drilling mud pumps

CMS 2000

Flushless Packing System

Chesterton CMS 2000 Flushless Packing System is an advanced stuffing box leakage control sealant made of high purity, reinforced fiber available in graphite, white and food grade (FP) non-staining formulations. This high purity, fiber reinforced sealant creates a solid composite ring that has no leak paths.

CMS 2000 pump sealant is provided in bulk form for initial loading and in cartridges* for final sealing under pressure to eliminate voids. Cartridges are then used for all subsequent resealing. Chesterton offers two CMS 2000 injection systems.

Product Reorder		
Description	Reorder Number	
	White	Black
Cartridge	001048	004431
CMS 2000 Injectable 13.2 liter	001047	004432
CMS 2000 Injectable 3.8 liter	001046	004433

Product Reorder	
Description	Reorder Number
CMS 2000-FP, 1 Gallon Pail	127533
CMS 2000-FP, 1 Quart Pail	127532

Not available in cartridges



For optimum performance Chesterton recommends the use of Chesterton Stabilizer Cage to maintain end ring loading in tough applications.

- Eliminates flush and reduces leakage to insignificant levels
- Will not score shaft sleeves
- Effective with worn, fretted sleeves
- An exclusive Internal Laminar Shear™ prevents frictional wear of shaft or sleeve
- Eliminate individual inventories and standardize plantwide with these formulations
- Never disassemble to repack again

Technical Data

Temperature Limit:

205°C (400°F), *White*

205°C (400°F), *Black*

205°C (400°F), *FP*

Shaft Speed:

10 m/s (2000 fpm), *White*

8 m/s (1600 fpm), *Black*

6 m/s (1200 fpm), *FP*

Chemical Resistance:

pH 1 to 13, *White*
not recommended for oxidizers, fluorine, chlorine trifluoride and related compounds, and molten alkali metals.

pH 4 to 13, *Black*
not recommended for oxidizing agents.

pH 0 to 14, *FP*

Applications:

CMS 2000 Black and White
Stock pumps, white water pumps, river water pumps, condensate pumps, water treatment pumps

CMS 2000-FP
Rotating equipment applications in the food processing and handling industry

*CMS 2000-FP is not available in cartridges.

Online Injector

The Online Injector can be attached directly to the lantern ring inlet port with a fitting that allows for topping off of the CMS as needed—without the need to carry additional equipment.

Product Reorder	
Description	Reorder Number
Online Injector Unit	329880
CMS 2000 Online Injector Refills, White (29 Pieces/Bucket)	004543
CMS 2000 Online Injector Refills, White (14 Pieces/Bucket)	004559
Online Injector - Plunger (Spare Part)	004544



Manual Injection System

The Manual Injection System comes in its own case, equipped with the manual hydraulic unit, a three foot hose, a one foot hose, a quart of hydraulic fluid, male and female flow-through fittings, a spanner wrench and a CMS 2000 volume calculator.

Product Reorder	
Description	Reorder Number
Manual Injection System	004403
3 FT Hose Alone	004444
1 FT Hose Alone	004422
1/4 NPT Female Alone	004428
1/4 NPT Male Alone	004427
1/4 NPT Plug Alone	004426
1/4 GG-S Pipe Connector Alone	004425



Pneumatic Injection System

The Pneumatic Injection System is the air powered version of the manual system. This eliminates the need to manually pressurize the delivery system. This system uses plant air pressure to assist in injecting the CMS material into the equipment. This system contains all the fittings of the manual system.

Product Reorder	
Description	Reorder Number
Pneumatic Injection System	004536



SuperSet™

Featuring SpiralTrac™

SuperSet combines the superior sealing capabilities of Chesterton’s mechanical packing products with the patented design of the EnviroSeal SpiralTrac Version P Environmental Controller for Packed Stuffing Boxes. This total sealing solution set is specifically designed and proven to increase packing and equipment service life while dramatically reducing flush rates. The savings are real—increased reliability with lower maintenance and operating costs.



- Dramatically reduces flush requirements up to 90%
- Extends packing life 2–6 times that of a standard packed stuffing box
- Prevents solids from getting between the packing and shaft
- Minimizes shaft/sleeve wear
- Typically reduces number of packing rings—40% in typical stuffing box
 - Less consolidation and fewer gland adjustments required
 - Easier repacking
 - No lantern ring movement

SuperSet offers a unique sealing solution for any application, and it helps dramatically reduce direct and indirect costs associated with packed pumps and equipment. Use less flush water more effectively and realize cost savings—SuperSet is the *ultimate sealing solution for packing*.

SuperSet Product Reorder to fit Ahlstrom® APP				
Bearing Unit	ID x OD x Cross Section mm	Number of Rings	Packing Type	Reorder Number
1	40 x 60 x 10.0	2	1400R	210204
			1730	210201
			1760	210202
			370	210203
			477-1T	210205
2	50 x 70 x 10.0	2	1400R	210210
			1730	210206
			1760	210207
			370	210209
			477-1T	210211
3	60 x 85 x 12.5	2	1400R	210215
			1730	210212
			1760	210213
			370	210214
			477-1T	210216
4	70 x 95 x 12.5	2	1400R	210221
			1730	210217
			1760	210218
			370	210219
			477-1T	210222
5	90 x 122 x 16.0	2	1400R	210227
			1730	210223
			1760	210225
			370	210226
			477-1T	210228
6	100 x 132 x 16.0	2	1400R	210233
			1730	210229
			1760	210231
			370	210232
			477-1T	210234

SuperSet Product Reorder to fit Ahlstrom® APT				
Bearing Unit	ID x OD x Cross Section Inches	Number of Rings	Packing Type	Reorder Number
1	1.625 x 2.375 x 0.375	2	1400R	210239
			1730	210236
			1760	210237
			370	210238
			477-1T	210241
2	2.000 x 2.750 x 0.375	2	1400R	210245
			1730	210242
			1760	210243
			370	210244
			477-1T	210246
3	2.375 x 3.375 x 0.500	2	1400R	210250
			1730	210247
			1760	210248
			370	210249
			477-1T	210251
4	2.750 x 3.750 x 0.500	2	1400R	210255
			1730	210252
			1760	210253
			370	210254
			477-1T	210257
5	3.500 x 4.750 x 0.625	2	1400R	210262
			1730	210258
			1760	210259
			370	210261
			477-1T	210263
6	3.937 x 5.197 x 0.625	2	1400R	210267
			1730	210264
			1760	210265
			370	210266
			477-1T	210268

Ahlstrom® is a registered trademark of Ahlstrom Corporation. SpiralTrac is a trademark of EnviroSeal Engineering Products Ltd.

Patent # 5,553,868, # 5,167,418 Euro. Pat. App. 0 912 848

Sealing Solution	Features	Applications
370 SuperSet	High Strength, high purity carbon fiber with multi-stage lube system. Excellent leakage control, capable of near zero to zero leakage. High-speed capability.	Virtually any application. Particularly suited for high speed, high temperature applications.
412-W SuperSet	White, synthetic yarn with high tensile strength and extrusion resistance.	Good for a wide variety of applications, in both clean products and slurries.
477-1T SuperSet	PTFE coated carbon fiber. Excellent extrusion resistance, good leakage control, minimal consolidation and gland adjustments required, excellent chemical resistance.	Slow speed equipment. Originally designed for chemical digestion processes in the Pulp & Paper Industry.
1400R SuperSet	Pure graphite with carbon reinforcement, excellent leakage control, capable of near zero to zero leakage, unaffected by frictional heat. Very conformable.	Virtually any application. Also suitable for use on sleeves with some wear. Good option for large, higher speed equipment.
1730 SuperSet	White synthetic fiber, non-staining, good leakage control with minimal gland adjustments, excellent resistance to heat.	General service in slurries and clean fluids.
1760 SuperSet	PTFE/graphite fiber. Excellent chemical resistance, good leakage control.	General service and highly aggressive chemical environments. Widely used in many industries.
1830SSP SuperSet	Expanded graphite PTFE yarn with low leakage capabilities.	For use in bauxite slurries, bottom ash pumps, minerals handling pumps, tailings, and other slurry processes.
GraphMax™ SuperSet	Pure graphite with carbon reinforced corners for extrusion and abrasion resistance.	Good for both clean liquids and slurries in a wide variety of industries.
InnerLube SuperSet	Synthetic composite yarn with built-in lubricant reservoirs.	Good for use in paper mills, wastewater, brine, river water, and other non-clean products.

SuperSet Product Reorder to fit Goulds®				
Pump Model	ID x OD x Cross Section Inches	Number of Rings	Packing Type	Reorder Number
3175 L	4.750 x 5.750 x 0.500	3	1400R	210033
			1730	210030
			1760	210031
			370	210032
			477-1T	210034
3175 M	3.750 x 4.750 x 0.500	3	1400R	210028
			1730	210025
			1760	210026
			370	210027
			477-1T	210029
3175 S	3.000 x 4.000 x 0.500	3	1400R	210023
			1730	210020
			1760	210021
			370	210022
			477-1T	210024
3196 LT	2.125 x 2.875 x 0.375	3	1400R	210013
			1730	210010
			1760	210011
			370	210012
			477-1T	210014
3196 MT	1.750 x 2.50 x 0.375	3	1400R	210008
			1730	210005
			1760	210006
			370	210007
			477-1T	210009
3196 ST	1.375 x 2.00 x 0.3125	3	1400R	210003
			1730	210000
			1760	210001
			370	210002
			477-1T	210004
3196 XLT	2.500 x 3.375 x 0.4375	3	1400R	210018
			1730	210015
			1760	210016
			370	210017
			477-1T	210019

SuperSet Product Reorder to fit Warman®				
Pump Model	ID x OD x Cross Section Inches	Number of Rings	Packing Type	Reorder Number
B Frame	1.785 x 2.435 x 0.3125	3	1730	210738
			1830-SSP	212036
			412-W	212055
			InnerLube™	212037
C Frame	2.312 x 3.064 x 0.375	3	1730	210739
			1830-SSP	212040
			412-W	212038
			GraphMax™	212039
			InnerLube™	212041
D Frame	3.250 x 4.250 x 0.500	3	1730	210741
			1830-SSP	212044
			412-W	212042
			GraphMax™	212043
			InnerLube™	212045
E Frame	4.000 x 5.250 x 0.625	3	1730	210742
			1830-SSP	212048
			412-W	212046
			GraphMax™	212047
			InnerLube™	212049
F Frame	5.125 x 6.625 x 0.750	3	1730	210744
			1830-SSP	212052
			412-W	212050
			GraphMax™	212051
			InnerLube™	212053

Goulds® is a registered trademark of ITT Industries.
Warman® is a registered trademark of Weir Minerals.

MULTI PURPOSE SEALING



1400R

Carbon Reinforced Graphite Tape

Chesterton 1400R is a unique reinforced braided graphite tape packing designed to handle both pump and valve applications. The 1400R utilizes a two-tiered reinforcement system to make it extrusion resistant and capable of withstanding high operating pressures. Each strand of graphite is reinforced with a carbon filament, and the overall braid is reinforced with additional strands of carbon yarn.

The outstanding heat conductivity and extreme temperature resistance of this graphite packing make it an excellent option for water management programs. Because of its thermal characteristics, this packing is capable of sealing many applications with little or no leakage, minimizing the amount of flush required. Unlike synthetic type yarns, this graphite/carbon packing is not strictly dependent on the cooling and lubrication provided by a flush.

The compressible graphite tape yarn combined with the carbon reinforcement make this packing a good sealing option on equipment with some sleeve, shaft, or stuffing box wear or imperfections. This can mean extended service time before a pump has to be removed for a costly sleeve or shaft replacement.

In addition to its excellent sealing capabilities in rotating equipment, 1400R is a superior valve sealing material. This dual purpose design makes it a truly universal mechanical packing.



- Best choice for high temperature
- Eliminates flush and effectively eliminates stuffing box leakage
- Self-lubricating to eliminate shaft or stem scoring and extend packing life

Technical Data

Temperature Limit:

650°C (1200°F) steam

455°C (850°F) oxidizing atmosphere

Pressure Limit:

275 bar g (4000 psig) valves

14 bar g (200 psig) pumps

Shaft Speed:

20 m/s (4000 fpm)

Chemical Resistance:

pH 0 to 14 except oleum, fuming nitric acid, and aqua regia

Applications:

Agitators, boiler feed pumps, condensate pumps, pulpers, stock pumps, refiners, mixers, also ideal for use in steam valves

Note: 477-1T can be used as a non-contaminating carbon yarn anti-extrusion end ring.

Product Reorder				
Size		Packaged ± 10%		Reorder Number
mm	Inch	kg	lbs	
3,0	1/8	0,908	2	000924
5,0	3/16	0,908	2	000926
6,0	-	0,908	2	000927
6,5	1/4	0,908	2	000937
		2,270	5	000941
8,0	5/16	0,908	2	001054
		2,270	5	001055
9,5	3/8	0,908	2	000943
		2,270	5	000944
		3,175	7	000946
10,0	-	0,908	2	000947
		2,270	5	000949
11,0	7/16	0,908	2	000950
		2,270	5	000952
12,0	-	0,908	2	000953
		2,270	5	000955
12,5	1/2	0,908	2	000956
		2,270	5	000958
		3,175	7	000959
14,0	9/16	2,270	5	001056
		3,175	7	001057
16,0	5/8	3,175	7	001058
17,5	11/16	3,175	7	001059
19,0	3/4	3,175	7	001071
20,5	13/16	3,175	7	001092
22,0	7/8	3,175	7	001093
24,0	15/16	3,175	7	001095
25,5	1	3,175	7	001096

477-1

Carbon Fiber

Chesterton 477-1 carbon fiber packing combines a new yarn formulation with superior blocking agents. New low modulus yarn provides the strength associated with continuous filament carbon fibers plus greater flexibility. This makes 477-1 strong yet pliable, without the brittleness of conventional carbon packings. 477-1 incorporates a high purity dispersion of inorganic platelets which prevent penetration of gases or liquids through the packing. Interbraid construction locks these blocking agents within the packing ring.



Product Reorder				
Size		Packaged ± 10%		Reorder Number
mm	Inch	kg	lbs	
3,0	1/8	0,908	2	004752
5,0	3/16	0,908	2	004754
6,0	–	0,908	2	004756
6,5	1/4	0,908	2	004730
		2,270	5	004731
8,0	5/16	0,908	2	004733
		2,270	5	004734
9,5	3/8	0,908	2	004722
		2,270	5	004723
		4,540	10	004724
10,0	–	0,908	2	004758
		2,270	5	004759
11,0	7/16	0,908	2	004736
		2,270	5	004737
12,0	–	0,908	2	004782
		2,270	5	004791
12,5	1/2	0,908	2	004726
		2,270	5	004727
		4,540	10	004728
14,0	9/16	2,270	5	004739
		4,540	10	004740
16,0	5/8	4,540	10	004742
17,5	11/16	4,540	10	004744
19,0	3/4	4,540	10	004700
20,5	13/16	4,540	10	004793
22,0	7/8	4,540	10	004746
24,0	15/16	4,540	10	004796
25,5	1	4,540	10	004748

- Strong yet pliable, continuous filament carbon yarn
- Unique inorganic blocking agent stops gas/liquid penetration
- Molybdenum based corrosion inhibitor prevents stem pitting

Technical Data

Temperature Limit:
565°C (1050°F)

Pressure Limit:
250 bar g (3600 psig) in valve applications

14 bar g (200 psig) in pump applications

Shaft Speed:
15 m/s (3000 fpm)

Chemical Resistance:
pH 0 to 13 except oleum, fuming nitric acid, aqua regia, and fluorine

Applications:
Virtually all pumps and valves against most solvents, gases, and other liquids

GraphMax™

Structurally Reinforced Graphite Packing

GraphMax is an interbraided graphite packing. Carbon yarns are incorporated in the braided structure in a way that allows very tight braiding and corner reinforcement that improves the strength of the packing. This dramatically improves the packing’s resistance to extrusion and blow out—one of the limitations with traditional flexible graphite tape packings.

GraphMax can be used in demanding rotating applications in, for instance, the power, pulp and paper, and ore processing industries where temperature and pressure resistance can be required in combination with chemical and abrasion resistance.

It’s applicability in valves makes it a plantwide general service packing.



- Exclusive construction for plantwide use in pumps and valves
- Sealing and extrusion resistance without wire reinforcement in a single spool
- Interbraid construction with carbon corner reinforcement maintains structural integrity for easy removal
- Self-lubricating to minimize shaft or stem scoring and extend packing life
- Carbon fiber reinforced graphite strands provide maximum extrusion resistance and high pressure capability

Product Reorder				
Size		Packaged ± 5%		Reorder Number
mm	Inch	kg	lbs	
9,5	3/8	0,908	2	150004
		2,270	5	150005
		3,175	7	150006
10,0	-	0,908	2	150007
		2,270	5	150008
11,0	7/16	0,908	2	150009
		2,270	5	150010
12,0	-	0,908	2	150011
		2,270	5	150012
12,5	1/2	0,908	2	150013
		2,270	5	038740
		3,175	7	038741
14,0	9/16	2,270	5	038738
		3,175	7	038744
16,0	5/8	3,175	7	038742
17,5	11/16	3,175	7	150019
19,0	3/4	3,175	7	038743
20,0	-	3,175	7	150021
20,5	13/16	3,175	7	150022
22,2	7/8	3,175	7	150023
24,0	15/16	3,175	7	150024
25,5	1	3,175	7	150025

Technical Data

Temperature Limit:

Maximum 650°C (1200°F)
steam service

Minimum -240°C (-400°F)

Pressure Limit:

260 bar g (3800 psig)* valves

28 bar g (400 psig) pumps

Shaft Speed:

17 m/s (3400 fpm)

Chemical Resistance:

pH 0 to 14 except oleum, fuming nitric acid, and aqua regia

Applications:

Pumps and valves against a wide variety of chemicals and slurry application

* For higher pressure limits consult Chesterton Engineering



VALVE SEALING

- Bonnet seals
- High performance
- Braided

5900

Graphite Bonnet Seals

Chesterton 5900 Graphite Bonnet Seals offer end users in the power industry improved reliability and leak tightness of pressure seal bonnet joints. These graphite bonnet seals are applicable for use on valves with screwed and bolted bonnets in steam and water. 5900 Bonnet Seals are also available with metal end caps.

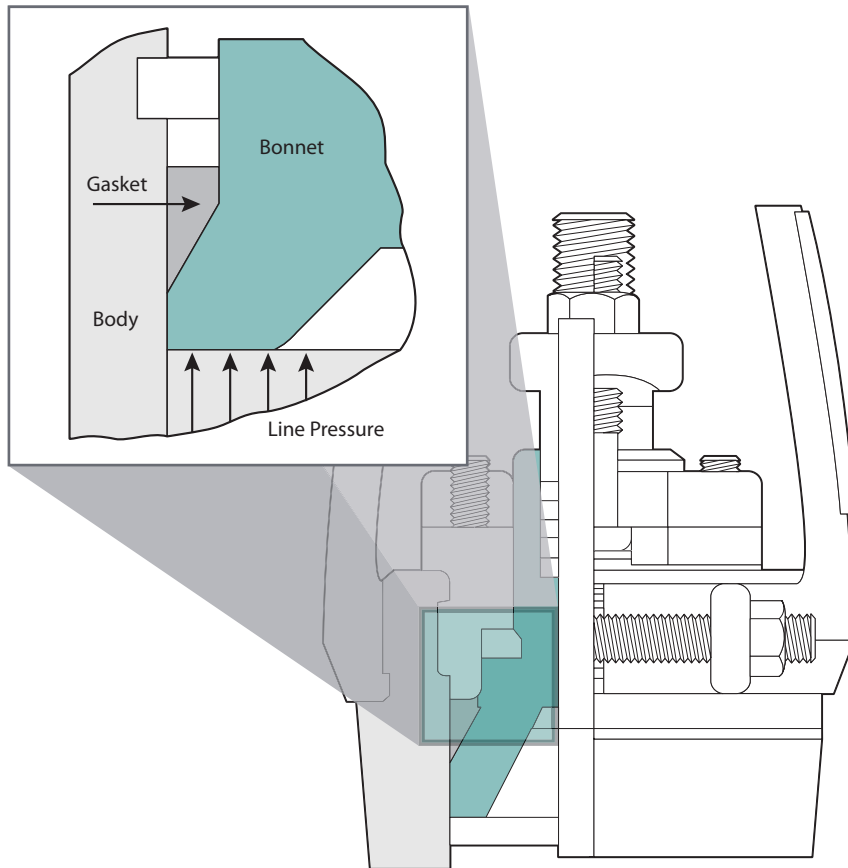

- Conforms easily to the valve's body and bonnet
- Maintains excellent anti-extrusion properties
- Requires significantly lower pressure to seal than traditional metal bonnet seals
- Enables easy removal without damage to the valve body

Technical Data

Temperature Limit:
650°C (1200°F)

Pressure Limit:
290 bar g (4200 psig)

Applications:
Valves in high pressure steam and water

1724E

Control Valve Kits

Chesterton’s 1724E Control Valve Kits are specifically designed to be used on pneumatically actuated control valves. 1724E is best suited for services where operating temperature is steady state with minimal thermal cycling, and in applications where the stem friction from pure graphite packing is too high for the valve’s actuator. The kit contains all the parts necessary to repack the valve in the field with Chesterton’s Live-Loading system.

The kit includes a 1724 five-ring die-formed PTFE packing set, a pre-cut carbon spacer, pre-engineered live-load assemblies, and new gland studs and nuts. All packing rings and spacers are cut to allow installation without removal of the valve actuator, simplifying the valve repacking procedure in the field. The live-load assemblies are easily identifiable by their uniquely shaped outer guide and are simple to install and use. Simply fit the assembly over the stud and tighten the gland bolt until the flat washer is flush with the top of the outer guide. No torque wrench is required.

1724E should be utilized with live-loading in control valves to ensure effective long term sealing over many cycles.

- Complete kit to repack a number of the most popular control valves in industry today
- VOC emissions services
- Reduced stem friction; lower actuation forces required
- Exceeds EPA VOC emissions requirements (<500 ppm as measured by EPA Method 21)
- Simplified installation—torque wrench not required
- Can be installed in the field without removing the valve actuator

1724E Control Valve Kits designed by Chesterton to fit Valtek® Valves			
Kit Number	Nominal Size	Pressure Class	Reorder Number
	Inch		
1	0.5 and 1	150# – 600#	148039
2	1.5 and 2	150# – 600#	148040
3	3	150# – 300#	148041
4	4	150# – 300#	148042
5	4	150# – 300#	148043
6	3	600#	148044
7	4	600#	148045
8	4	600#	148046
9	6	150#	148047
10	6	150#	148048
11	6	300#	148049
12	6	300#	148050
13	6	600#	148051
14	6	600#	148052
15	8	150#	148053
16	8	300#	148054
17	8	300#	148055
18	8	600#	148056
19	8	600#	148057

Valtek® is a trademark of Flowserve Corporation.



1724E Control Valve Kits designed by Chesterton to fit Masoneilan® Control Valves					
10,000 New Series					
Pressure Class	Pipe Diameter	Stem OD Inch	Box Bore Inch	Cross Section	Reorder Number
150-300	4	0.500	0.875	0.1875	148241
	6	0.625	1.000	0.1875	148242
	8	0.750	1.250	0.2500	148243
150-600	2, 3, or 4	0.500	0.875	0.1875	148241
600	6	0.625	1.000	0.1875	148242
	8	0.750	1.250	0.2500	148243
21,000 New Series					
150-300	3 or 4	0.500	0.875	0.1875	148241
	6	0.750	1.250	0.250	148243
150-600	0.750, 1 or 1.5	0.500	0.875	0.1875	148241
	2, 3 or 4	0.500	0.875	0.1875	148241
600	6	0.750	1.250	0.2500	148243
41,000 Old Series					
150-600	1.5 or 2	0.500	0.875	0.1875	148244
	3 or 4	0.625	1.000	0.1875	148246
	6	0.750	1.250	0.2500	148249
	8	1.000	1.625	0.3125	148251
900-1500	2	0.500	0.875	0.1875	148245
	3	0.625	1.000	0.1875	148427
	4	0.625	1.000	0.1875	148248
	6	0.750	1.250	0.2500	148250

1724E Control Valve Kits designed by Chesterton to fit Fisher® Control Valves			
Kit Number and Packing Size Inch	Nominal Size	Pressure Class	Reorder Number
	Inch		
1 – 0.375 x 0.875	1 and 1.5	150# – 300#	148004
2 – 0.500 x 1.000	2, 3 and 4	150# – 300#	148005
3 – 0.750 x 1.375	6 and 8	150# – 300#	148006
4 – 0.750 x 1.3751	6 and 8	600#	148007

Technical Data

Maximum Service Temperature:
200°C (400°F)

Chemical Resistance:
pH 0 to 14

Inert to all common chemicals except molten alkali metals, elemental fluorine, and strong oxidizers.

Applications:

Air operated control valves, light and heavy hydrocarbon services

Fisher® is a registered trademark of Emerson Electric Co.
Masoneilan® is a registered trademark of Dresser, Inc.

5800

WedgeSeal™

Chesterton 5800 WedgeSeal is manufactured from high purity graphite. The die-formed rings are non-absorbent and non-wicking. A corrosion inhibitor is incorporated into the rings to help prevent electrolytic pitting. At elevated system pressures, 5800 gives the added benefit of reduced stem friction while sealing effectively, thus critical control valves with limited torque capabilities can respond more rapidly and precisely throughout the pressure range up to peak system pressure. Five-year warranty available when used with 5150 Live Loading assemblies.

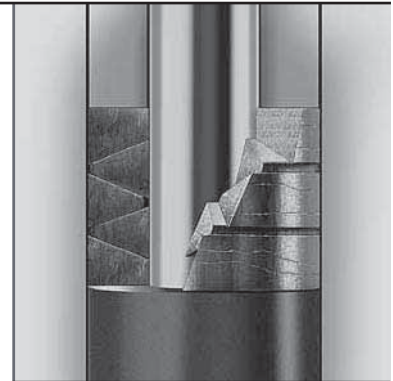

Chesterton WedgeSeal Design

Provides a more efficient gland load transfer to packing set and makes the set more responsive to system requirements.

Two OD end rings and one middle sealer ring

- Primary static end-cap sealer rings
- Die formed, high purity graphite tape
 - Increases thermal stability
 - Decreases porosity and consolidation
 - Non-absorbent, non-wicking
 - Passive corrosion inhibitor

Two ID sealer rings

- Primary dynamic sealing rings
- Die formed graphite—ideal combination to maximize performance
- Passive corrosion inhibitor

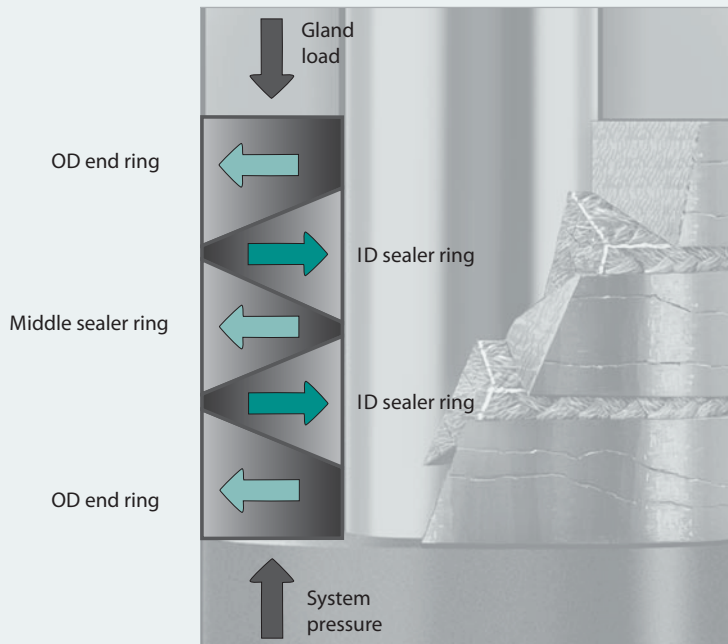

- **The high technology solution for modulated, actuated valves**
- **Reduced stem friction; lower actuation force needed**
- **Passes API 589 Fire Test**
- **Certifiable for nuclear service**

Technical Data

Temperature Limit:
2760°C (5000°F)

Pressure Limit:
For steam services between 210 bar g (3000 psig) and 310 bar g (4500 psig), use 477-1 or 1600 end rings

Chemical Resistance:
pH 0 to 14

Applications:
Nuclear and process industry services to seal, MOV's, AOV's, and steam services

5800E

Emissions WedgeSeal™

Chesterton 5800E WedgeSeal is designed for high temperature, fugitive emissions service in friction sensitive valves. Combining Chesterton’s 5800 pure die-formed graphite sealing rings with our 477-1 braided carbon yarn end rings, the WedgeSeal seals to extremely low VOC emissions levels while providing minimal friction against the stem. The carbon/graphite base materials in the set are unaffected by high temperatures, and the set passes the API 589 Fire Test, ensuring maximum safety in hazardous services. The WedgeSeal set incorporates passive corrosion inhibitors that retard electrolytic pitting. The most important feature of this design is the reduced stem friction which ensures that the valve actuator can respond to system changes more rapidly and precisely.



- Graphite packing sets for fugitive emissions service
- Designed specifically for air operated control valves
- Reduced stem friction; lower actuation force required
- Passes API 589 Fire Test

Product Reorder			
ID Inch	OD Inch	Cross Section	Reorder Number
0.312	0.750	0.219	005456
0.375	0.750	0.187	005454
0.375	0.875	0.250	005445
0.437	0.812	0.187	005461
0.437	1.125	0.344	005493
0.437	0.687	0.500	005540
0.500	0.875	0.187	005453
0.500	1.000	0.250	005446
0.511	1.062	0.275	005541
0.562	1.000	0.218	005528
0.625	1.000	0.187	005452
0.625	1.125	0.250	005463
0.629	1.023	0.197	005534
0.750	1.125	0.187	005529
0.750	1.250	0.250	005455
0.750	1.375	0.312	005447
0.750	1.500	0.375	005544
0.787	1.496	0.354	005543
0.875	1.250	0.187	005449
0.875	1.375	0.250	005471
0.875	1.500	0.312	005472
0.905	1.417	0.256	005542
0.937	2.312	0.687	005555
1.000	1.375	0.187	005521
1.000	1.500	0.250	005482
1.000	1.625	0.312	005444
1.000	1.750	0.375	005484
1.125	1.625	0.250	005450
1.125	1.750	0.312	005547
1.125	1.875	0.375	005549
1.125	2.312	0.594	005554
1.125	2.375	0.625	005557
1.125	2.500	0.687	005559
1.181	1.772	0.296	005548
1.181	1.811	0.315	005526

Product Reorder			
ID Inch	OD Inch	Cross Section	Reorder Number
1.250	1.625	0.187	005545
1.250	1.750	0.250	005520
1.250	1.912	0.331	005532
1.250	2.000	0.375	005457
1.250	2.250	0.500	005553
1.250	2.625	0.687	005561
1.255	1.925	0.335	005550
1.260	1.732	0.236	005546
1.375	2.000	0.312	005551
1.375	2.125	0.375	005552
1.375	2.375	0.500	005556
1.500	2.000	0.250	005496
1.500	2.125	0.312	005486
1.500	2.250	0.375	005488
1.500	2.281	0.390	005497
1.625	2.375	0.375	005536
1.625	2.625	0.500	005560
1.750	2.250	0.250	005538
1.750	2.500	0.375	005558
1.750	2.750	0.500	005522
1.875	2.500	0.312	005523
1.875	2.625	0.375	005535
2.000	2.500	0.250	005451
2.000	3.000	0.500	005562
2.035	3.060	0.513	005563
2.125	3.125	0.500	005595
2.125	3.155	0.515	005596
2.250	3.250	0.500	006059
2.500	3.000	0.250	005530
2.500	3.250	0.375	005597
2.500	3.560	0.500	006144
2.500	3.530	0.515	006130
3.000	4.000	0.500	006145
3.000	4.125	0.562	006135

Technical Data

Temperature Limit:

From -40°C (-40°F)
up to 565°C (1050°F)

Maximum Pressure Limit:
250 bar g (3600 psig)

Chemical Resistance:
pH 0 to 13

Applications:

Light and heavy hydrocarbon services, steam services, chronic leakers in fugitive emissions services—block or control valve

Live loading is recommended for most applications

Note: Also available 5800T for low temperature service -180°C to 230°C (-300°F to 450°F) and 315°C (600°F) in steam services.

5800E

Control Valve Kits

Chesterton 5800E Control Valve Kits are specifically designed to be used on pneumatically actuated control valves. The kit contains all parts necessary to repack the valve in the field with Chesterton’s Live-Loading system; the set includes a 5800E packing set, a pre-cut carbon spacer, pre-engineered live-load assemblies, and new gland studs and nuts. All packing rings and spacers are cut to allow installation without removal of the valve actuator, simplifying the valve repacking procedure in the field. The cartridge live-load assemblies are easily identifiable by their uniquely shaped outer guide and are simple to install and use. Simply fit the assembly over the stud and tighten the gland bolt until the flat washer is flush with the top of the outer guide. No torque wrench is required.

The 5800E WedgeSeal™ is a combination packing set that utilizes Chesterton’s unique wedge shaped, die-formed sealing set along with our 477-1 braided carbon end rings. The 5800E set has been proven to seal to extremely low VOC emissions levels. Reduced stem friction ensures that the valve will respond to system changes more rapidly and precisely. Passive corrosion inhibitors are impregnated in the packing set to help prevent electrolytic pitting. The WedgeSeal set also passes API 589 fire testing, thus ensuring maximum safety in hazardous services.

- Complete kits to repack a number of the most popular control valves in industry today
- For high temperature, VOC emissions services
- Reduced stem friction; lower actuation forces required
- Exceeds EPA VOC emissions requirements (<500 ppm as measured by EPA Method 21)
- Simplified installation—torque wrench not required
- Can be installed in the field without removing the valve actuator
- Meets API 589 Fire Test

5800E Control Valve Kits designed by Chesterton to fit Valtek® Valves			
Kit Number	Nominal Size	Pressure Class	Reorder Number
	Inch		
1	0.5 and 1	150# – 600#	148009
2	1.5 and 2	150# – 600#	148010
3	3	150# – 300#	148011
4	4	150# – 300#	148012
5	4	150# – 300#	148013
6	3	600#	148014
7	4	600#	148015
8	4	600#	148016
9	6	150#	148017
10	6	150#	148018
11	6	300#	148019
12	6	300#	148020
13	6	600#	148021
14	6	600#	148022
15	8	150#	148023
16	8	300#	148024
17	8	300#	148025
18	8	600#	148026
19	8	600#	148027

Valtek® is a trademark of Flowserve Corporation.

5800E Control Valve Kits designed by Chesterton to Fit Masoneilan® Valves					
10,000 New Series					
Pressure Class	Pipe Diameter	Stem OD Inch	Box Bore Inch	Cross Section	Reorder Number
150-300	4	0.500	0.875	0.1875	148224
	6	0.625	1.000	0.1875	148225
	8	0.750	1.250	0.2500	148226
150-600	2, 3 or 4	0.500	0.875	0.1875	148224
600	6	0.625	1.000	0.1875	148225
	8	0.750	1.250	0.2500	148227
21,000 New Series					
150-300	3 or 4	0.500	0.875	0.1875	148224
	6	0.750	1.250	0.2500	148226
150-600	0.750, 1 or 1.5	0.500	0.875	0.1875	148224
	2, 3 or 4	0.500	0.875	0.1875	148224
600	6	0.750	1.250	0.2500	14227
41,000 Old Series					
150-600	1.5 or 2	0.500	0.875	0.1875	148228
	3	0.625	1.000	0.1875	148230
	4	0.625	1.000	0.1875	148232
	6	0.750	1.250	0.2500	148233
	8	1.000	1.625	0.3125	148235
900-1500	2	0.500	0.875	0.1875	148229
	3 or 4	0.625	1.000	0.1875	148231
	6	0.750	1.250	0.2500	148234

5800E Control Valve Kits designed by Chesterton to fit Fisher® Valves			
Kit Number and Packing Size	Nominal Size	Pressure Class	Reorder Number
	Inch		
1 – 0.375 x 0.875	1 and 1.5	150# – 300#	147995
2 – 0.500 x 1.000	2, 3 and 4	150# – 300#	147996
3 – 0.750 x 1.375	6 and 8	150# – 300#	147997
4 – 0.750 x 1.375	6 and 8	600#	147998



Technical Data

Temperature Limit:

565°C (1050°F)

Applications:

Air Operated Control Valves
Light and heavy hydrocarbon services

Fisher® is a registered trademark of Emerson Electric Co.
Masoneilan® is a registered trademark of Dresser, Inc.

5800T

Low Friction WedgeSeal™

Control valves are friction sensitive applications. High packing friction can result in overall decreased system efficiency and reduced production output. In lower temperature services, the most common sealing option is a PTFE V-ring set which provides good sealability and low stem friction during normal use. But, pure PTFE sets do not tolerate large temperature changes and are prone to creep and cold flowing. Fluoroelastomer V-ring packing sets offer improved performance especially at higher temperatures, but they can be very expensive. Pure graphite packings have excellent thermal and physical stability, but have higher coefficients of friction than PTFE.

Chesterton's 5800T combines the excellent thermal and physical stability of graphite and the low friction properties of PTFE. The packing set incorporates the unique Chesterton WedgeSeal design with an innovative graphite/PTFE hybrid packing material. This specially designed hybrid yarn contains a thermally stable base of pure graphite tape overknitted with a thin web of pure PTFE filament. The complete packing set uses the graphite/PTFE hybrid against the dynamic stem where friction is the concern. The static sealing components use Chesterton's pure 5300 graphite tape with a passive corrosion inhibitor.

This design gives 5800T the low friction properties comparable to pure PTFE packings. Unlike PTFE designs, the sealability of 5800T is unaffected by changes in temperature. Because it is mostly graphite by design, the 5800T undergoes minimal volume loss at higher temperatures, maintaining a tight seal even during system upsets. And, of course, the 5800T meets the difficult sealing requirements of both state and federal regulations for VOC emissions and in steam services.

- Designed specifically for air operated control valves
- For service temperatures below 230°C (450°F)
- Exceeds U.S. EPA requirements for emissions services (<500 ppm as measured by EPA Method 21)
- Very low friction design ensures most efficient valve operation
- Passes API 589 Fire Test

Chesterton WedgeSeal Design

Provides a more efficient gland load transfer to packing set and makes the set more responsive to system requirements.

Two OD end rings and one middle sealer ring

- Primary static end-cap sealer rings
- Die formed, high purity graphite tape
 - Increases thermal stability
 - Decreases porosity and consolidation
 - Non-absorbent, non-wicking
 - Passive corrosion inhibitor

Two ID sealer rings

- Primary dynamic sealing rings
- Die formed graphite—ideal combination to maximize performance
- Low PTFE content
 - Reduces stem friction and lowers actuator force
 - Minimizes slip-stick and is more responsive to adjustments
- Passive corrosion inhibitor

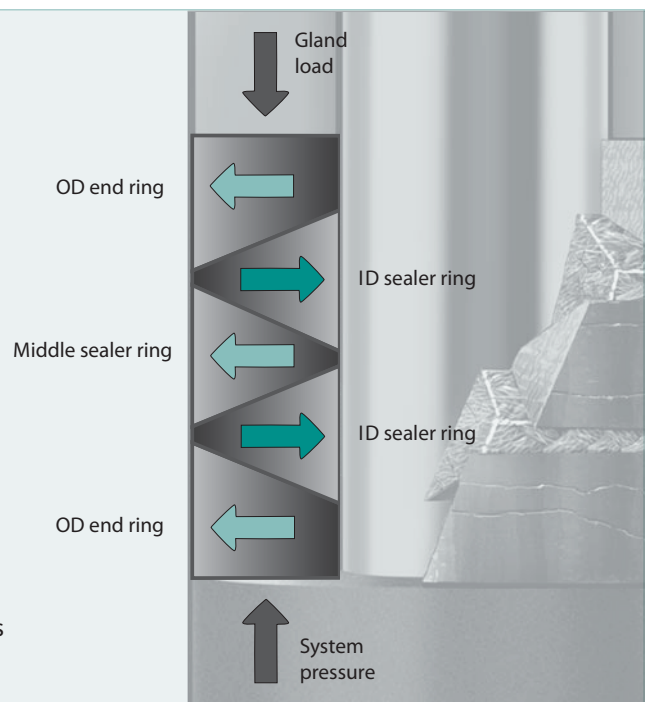



5800T Product Reorder			
ID Inch	OD Inch	Cross Section	Reorder Number
0.312	0.750	0.219	059814
0.375	0.750	0.187	059800
0.375	0.875	0.250	059989
0.437	0.812	0.187	059801
0.437	1.125	0.344	059847
0.437	0.687	0.500	059893
0.500	0.875	0.187	059802
0.500	1.000	0.250	059990
0.511	1.062	0.275	059835
0.562	1.000	0.218	059811
0.625	1.000	0.187	059803
0.625	1.125	0.250	059816
0.629	1.023	0.197	059810
0.750	1.125	0.187	059804
0.750	1.250	0.250	059817
0.750	1.375	0.312	059991
0.750	1.500	0.375	059851
0.787	1.496	0.354	059850
0.875	1.250	0.187	059805
0.875	1.375	0.250	059818
0.875	1.500	0.312	059838
0.905	1.417	0.256	059834
0.937	2.312	0.687	059934
1.000	1.375	0.187	059807
1.000	1.500	0.250	059819
1.000	1.625	0.312	059839
1.000	1.750	0.375	059992
1.125	1.625	0.250	059823
1.125	1.750	0.312	059840
1.125	1.875	0.375	059856
1.125	2.312	0.594	059928
1.125	2.375	0.625	059930
1.125	2.500	0.687	059935
1.181	1.772	0.296	059836
1.181	1.811	0.315	059844

5800T Product Reorder			
ID Inch	OD Inch	Cross Section	Reorder Number
1.250	1.625	0.187	059809
1.250	1.750	0.250	059826
1.250	1.912	0.331	059845
1.250	2.000	0.375	059862
1.250	2.250	0.500	059894
1.250	2.625	0.687	059942
1.255	1.925	0.335	059846
1.260	1.732	0.236	059813
1.375	2.000	0.312	059841
1.375	2.125	0.375	059864
1.375	2.375	0.500	059896
1.500	2.000	0.250	059827
1.500	2.125	0.312	059842
1.500	2.250	0.375	059865
1.500	2.281	0.390	059891
1.625	2.375	0.375	059866
1.625	2.625	0.500	059898
1.750	2.250	0.250	059828
1.750	2.500	0.375	059868
1.750	2.750	0.500	059900
1.875	2.500	0.312	059843
1.875	2.625	0.375	059872
2.000	2.500	0.250	059831
2.000	3.000	0.500	059901
2.035	3.060	0.513	059920
2.125	3.125	0.500	059902
2.125	3.155	0.515	059921
2.250	3.250	0.500	059903
2.500	3.000	0.250	059833
2.500	3.250	0.375	059884
2.500	3.560	0.500	059904
2.500	3.530	0.515	059922
3.000	4.000	0.500	059905
3.000	4.125	0.562	059923

Technical Data

Temperature Limit:

-180°C to 230°C
(-300°F to 450°F)
315°C (600°F) in steam services

Pressure Limit:

172 bar g (2500 psig)

Chemical Resistance:

pH 0 to 14

Applications:

Light and heavy hydrocarbon services, low temperature steam services, chronic leakers in fugitive emissions services
Live-loading is recommended for most applications

5800T

Low Friction Control Valve Kits

Chesterton 5800T Low Friction Control Valve Kits are specifically designed to be used on pneumatically actuated control valves. The kit contains all parts necessary to repack the valve in the field with Chesterton’s Live-Loading system. The set includes a 5800T packing set, a pre-cut carbon spacer, pre-engineered live-load assemblies and new gland studs and nuts. All packing rings and spacers are cut to allow installation without removal of the valve actuator, simplifying the valve repacking procedure in the field.

The cartridge live-load assemblies are easily identifiable by their uniquely shaped outer guide, and are simple to install and use. Simply fit the assembly over the stud and tighten the gland bolt until the flat washer is flush with the top of the outer guide. No torque wrench is required.

Chesterton’s 5800T combines the excellent thermal and physical stability of graphite with the low friction properties of PTFE. The packing set incorporates the unique Chesterton WedgeSeal™ design with an innovative graphite/PTFE hybrid packing material. This specially designed hybrid yarn contains a thermally stable base of pure graphite tape overknitted with a thin web of pure PTFE filament. The complete packing set uses the graphite/PTFE hybrid against the dynamic stem where friction is the concern. The static sealing components use Chesterton’s pure 5300 graphite tape with a passive corrosion inhibitor.



- Complete kit to repack a number of the most popular control valves in industry today
- For VOC emissions services
- Very low stem friction; lower actuation forces required
- Exceeds EPA VOC emissions requirements (<500 ppm as measured by EPA Method 21)
- Simplified installation—torque wrench not required
- Can be installed in the field without removing the valve actuator
- Passes API 589 Fire Test

5800T Control Valve Kits designed by Chesterton to fit Valtek Mark One™ Valves

Kit Number	Size Inch	Pressure Rating	Reorder Number
1	1/2, 1	150 – 600	148081
2	1 1/2, 2	150 – 600	148082
3	3	150 – 300	148083
4	4	150 – 300	148084
5	4	150 – 300	148085
6	3	600	148086
7	4	600	148087
8	4	600	148088
9	6	150	148089
10	6	150	148090
11	6	300	148091
12	6	300	148092
13	6	600	148093
14	6	600	148094
15	8	150	148095
16	8	300	148096
17	8	300	148097
18	8	600	148098
19	8	600	148099

Valve Sealing System

A complete approach to valve sealing for nuclear and fossil plants, refineries, and chemical plants

This system has been proven by years of service in the industry. A Chesterton-trained technical specialist surveys all applicable valves. Information is then cross-checked against one of the industries' largest computerized valve data banks, and a specific packing arrangement is engineered for each valve application. A torque value for each valve is computed. Valve sealing materials can be certified to suit the unique requirements of individual nuclear plants. A Chesterton-trained specialist is available on-site prior to and during outages.

The Chesterton Live Loading provides automatic gland adjustments to keep packing sets under constant pressure, thereby reducing the chance of valve packing blowouts due to line pressure surges. It seals against vacuum, eliminating air ingestion problems.

A five-ring packing set decreases installation time, thus eliminating costs of unnecessary packing materials, reduces labor required to unpack deep stuffing boxes, minimizes hystereses of motor operated and air operated control valves. Low levels of contaminants in Chesterton packing materials reduce the likelihood of stress corrosion cracking. The packing material contains a passive corrosion inhibitor, virtually eliminating valve stem pitting.

In-plant training seminars are conducted by Chesterton-trained technical sealing device specialists.

- The Chesterton Valve Sealing System offers a solution to valve leakage problems associated with conventionally packed valves
- Zero leakage rates are obtainable, providing dramatic reductions in maintenance costs
- Live loading eliminates the need for excessive gland force, continually compensating for in-service packing consolidation
- Valve sealing satisfaction is assured with a Five-Year warranty



5150 Live Loading Assembly

Stacked arrangements of uniquely designed disc springs automatically adjust the gland to maintain constant, optimal sealing pressure on the packing set. Prevents leakage due to aging, consolidation, or thermal cycling. Eliminates the need for frequent manual adjustments, decreasing costly maintenance time and exposure/contamination levels. The live load assembly is capable of storing many times the elastic energy of standard gland bolts. Maintains optimal leakage control with minimal force, making live loading especially valuable for motor operated or inaccessible valves.



5150 Cartridge Valve Live Loading

The cartridge is a 5150 assembly outer container engineered for a valve's specific operating parameters. This results in the correct load being applied to the 5150 assembly based on cartridge height. The stainless steel cartridge makes installation and maintenance easier.



One-CI Braided Graphite Rings

Chesterton One-CI is a low friction, high density graphite packing manufactured from a pure, high quality yarn without any fillers or binders. It functions as a combination wiper and anti-extrusion ring. One-CI disperses heat and withstands temperatures to 2760°C (5000°F) in the absence of an oxidizing agent with no apparent weight loss.



5300 (GTPI) Die-Formed Inhibited Graphite Rings

Chesterton 5300 is a self-lubricating, low friction, high purity, precompressed, die-formed ring manufactured from pure graphite ribbon tape without any fillers, binders, or resins. Each ring is engineered to produce an accurate specific density for compression resistance, elasticity and retention of size and shape—all of which are necessary to provide the best possible valve sealing performance.

5300 can withstand temperatures to 2760°C (5000°F) in a non-oxidizing atmosphere. Both One-CI and 5300 incorporate an inorganic, passive inhibitor that reduces the corrosive properties of graphite by producing a protective barrier between the packing and the stem that will not degrade at high temperatures.



5100 Split Carbon Sleeves

Independent testing confirmed by Chesterton Engineering clearly indicates that a five-ring packing set produces optimum valve sealing. To effectively reduce the number of rings in a stuffing box, the Chesterton system uses a precision machined split carbon sleeve as a spacer in the bottom of the stuffing box. 5100 is manufactured from 99% pure graphite material which has a high compressive strength and a low coefficient of expansion. Four inch lengths are available to fit most stuffing boxes.



1600

Reinforced Graphite Tape

Chesterton 1600 features advanced construction for superior leakage control and high integrity. Layers of graphite tape are plied into compact strands. Each strand is reinforced with an Inconel® wire mesh covering. Strands are square plait braided to form a dense but pliable packing. It is further enhanced with blocking agents. The packing's exterior is then densely impregnated with lubricating agents to reduce stem friction and a corrosion inhibitor to prevent pitting.

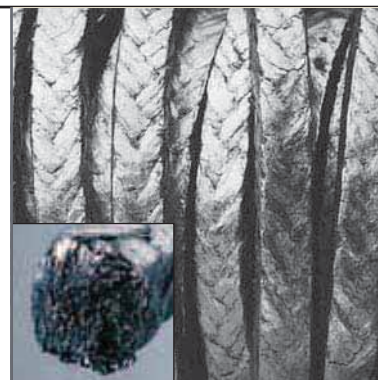

Product Reorder				
Size		Packaged ± 10%		Reorder Number
mm	Inch	kg	lbs	
3,0	1/8	0,908	2	035002
4,0	–	0,908	2	035004
5,0	3/16	0,908	2	035006
6,0	–	0,908	2	035008
6,5	1/4	0,908	2	035010
		2,270	5	035011
8,0	5/16	0,908	2	035013
		2,270	5	035014
9,5	3/8	0,908	2	035016
		2,270	5	035017
		4,540	10	035018
10,0	–	0,908	2	035020
		2,270	5	035021
11,0	7/16	0,908	2	035023
		2,270	5	035024
12,0	–	2,270	5	035026
12,5	1/2	0,908	2	035028
		2,270	5	035029
		4,540	10	035030
14,0	9/16	2,270	5	035032
		4,540	10	035033
16,0	5/8	4,540	10	035035
17,5	11/16	4,540	10	035037
19,0	3/4	4,540	10	035039
22,0	7/8	4,540	10	035041
25,5	1	4,540	10	034943

- Superior emissions control over thousands of cycles
- Fire safe: passes API 589 standards at API 607 temperatures and pressures as tested by an independent laboratory
- Easy installation and extrusion resistance in a single-spool packing
- Proven in high pressure, high temperature steam service

Technical Data

Temperature Limit:

650°C (1200°F) steam
455°C (850°F) oxidizing environment

Pressure Limit:

580 bar g (8400 psig)

Chemical Resistance:

pH 0 to 14 except in strong oxidizers

Applications:

All control and block valves

Inconel® is a registered trademark of Special Metals Corporation.

1601

Reinforced Graphite Tape

Chesterton 1601 features advanced construction for superior leakage control and high integrity. Layers of graphite tape are plied into compact strands. Each strand is reinforced with an Inconel® wire mesh covering. Strands are square plait braided to form a dense but pliable packing. It is further enhanced with blocking agents. The packing’s exterior is then densely impregnated with lubricating agents to reduce stem friction and a corrosion inhibitor to prevent pitting.

Chesterton 1601 is uniquely formulated to meet the purity requirements of the nuclear industry. Certificate of Compliance and Test Analysis available upon request.

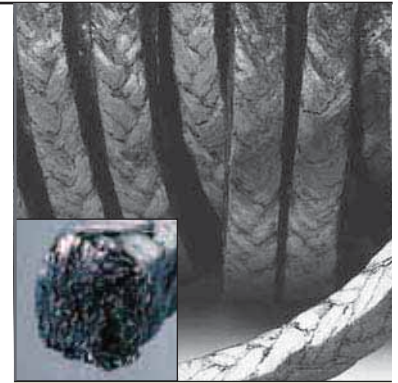

- Superior emissions control over thousands of cycles
- Fire safe: Passes API 589 standards at API 607 temperatures and pressures as tested by an independent laboratory
- Easy installation and extrusion resistance in a single-spool packing
- Proven in high pressure, high temperature steam service

Technical Data

Temperature Limit:

650°C (1200°F) steam
 455°C (850°F) oxidizing environment

Pressure Limit:

580 bar g (8400 psig)

Chemical Resistance:

pH 0 to 14 except in strong oxidizers

Applications:

All control and block valves

Product Reorder				
Size		Packaged ± 10%		Reorder Number
mm	Inch	kg	lbs	
3,0	1/8	0,908	2	034902
4,0	–	0,908	2	034904
5,0	3/16	0,908	2	034906
6,0	–	0,908	2	034908
6,5	1/4	0,908	2	034910
		2,270	5	034911
8,0	5/16	0,908	2	034913
		2,270	5	034914
9,5	3/8	0,908	2	034916
		2,270	5	034917
		4,540	10	034918
10,0	–	0,908	2	034920
		2,270	5	034921
11,0	7/16	0,908	2	034923
		2,270	5	034924
12,0	–	2,270	5	034926
12,5	1/2	0,908	2	034928
		2,270	5	034929
		4,540	10	034930
14,0	9/16	2,270	5	034932
		4,540	10	034933
16,0	5/8	4,540	10	034935
17,5	11/16	4,540	10	034937
19,0	3/4	4,540	10	034939
22,0	7/8	4,540	10	034941
25,5	1	4,540	10	034943

Inconel® is a registered trademark of Special Metals Corporation.

1622

Low Emissions Graphite Tape

Chesterton® 1622 Low Emissions Packing is designed to minimize valve emissions. It exceeds current emissions requirements for the refinery, petrochemical, and chemical industries and is ideal for block valve standardization.

Constructed from an Inconel® reinforced graphite, 1622 is a non-hardening, flexible packing that will not shrink or absorb moisture. Provided as a single spool solution, 1622 is easy to install and can be used to standardize your block valve stem packings, reducing inventories and installation errors caused by wrong packing selection and installation.

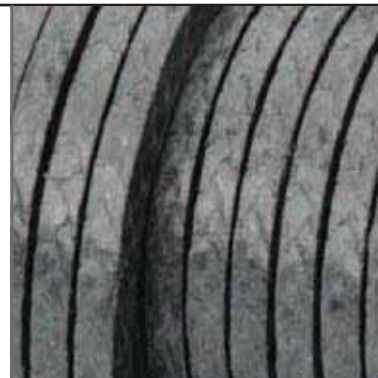

Product Reorder					
Cross Section Size		Average Stem Diameter		Average No. of Valves (per box)	Reorder Number
mm	Inch	mm	Inch		
	1/8		0.500	83	054700
	3/16		0.625	59	054701
6,0		25		31	054702
6,5	1/4		0.875	73	054703
8,0	5/16		1.250	39	054705
9,5	3/8		1.625	22	054707
10,0		40		24	054711
11,0	7/16		2.000	14	054713
12,0		70		9	054715
12,5	1/2		2.750	8	054716
14,0	9/16		3.250	6	054719
16,0	5/8		4.000	4	054721
17,5	11/16		5.000	3	054722
19,0	3/4	These sizes are available on request.			
20,0					
22,0	7/8				
24,5	1				

- **Extremely low published emissions for any spool packing per API 622**
 - Currently exceeds most emission requirements
- **Engineered packing set emissions capability from a single spool of packing**
 - Fits a wide range of block valves, thus minimizing inventory
 - Reduces the chance of errors in packing selection
 - Simplifies installation
- **Meets Consent Decree requirements**
 - Low-Leaking Valve Packing Technology
 - Reduce LDAR monitoring costs

Technical Data

Temperature Limit:

650°C (1200°F) in steam
450°C (850°F) in oxidizing atmosphere

Pressure Limit:

260 bar g (3800 psig)

Chemical Resistance:

pH 0 to 14 except in strong oxidizers

Applications:

Light and heavy hydrocarbons, VOCs, VHAPs, steam, and most non-oxidizing chemicals

Valve Packing Emission Warranty:

Chesterton 1622 packing will not leak in excess of 100 ppm for a period of 5 years. See your Chesterton representative for conditions and details of warranty.

Inconel® is a registered trademark of Special Metals Corporation.

1724

Non Hardening PTFE Yarn

Chesterton 1724 is a PTFE valve packing specially treated with protective lubricants. With 1724's unique formulation and construction you can't squeeze out the lubricants. It will not harden and it will not deteriorate in a wide range of chemical applications. Chesterton 1724 is guaranteed for the life of the valve. If it doesn't outlast the valve it's in, we'll replace it for FREE.*



Product Reorder				
Size		Packaged ± 10%		Reorder Number
mm	Inch	kg	lbs	
3,0	1/8	0,908	2	003260
4,0	-	0,908	2	003261
5,0	3/16	0,908	2	003262
6,0	-	0,908	2	003263
6,5	1/4	0,908	2	003264
		2,270	5	003273
8,0	5/16	0,908	2	003265
		2,270	5	003274
9,5	3/8	0,908	2	003266
		2,270	5	003275
		4,540	10	003281
10,0	-	0,908	2	003267
		2,270	5	003276
11,0	7/16	0,908	2	003268
		2,270	5	003277
12,0	-	0,908	2	003269
		2,270	5	003278
12,5	1/2	0,908	2	003270
		2,270	5	003279
		4,540	10	003283
14,0	9/16	2,270	5	003280
		4,540	10	003284
16,0	5/8	4,540	10	003285
17,5	11/16	4,540	10	003286
19,0	3/4	4,540	10	003287
20,5	13/16	4,540	10	003288
22,0	7/8	4,540	10	003289
24,0	15/16	4,540	10	003293
25,5	1	4,540	10	003294

- Excellent chemical resistance
- Non-hardening
- Guaranteed for the life of the valve

Technical Data

Temperature Limit:
260°C (500°F)

Pressure Limit:
210 bar g (3000 psig)

Chemical Resistance:
pH 0 to 14

Applications:
Valves handling steam, severe chemicals and solvents

*Contact your local Chesterton representative for a copy of the written guarantee.

324

Non Hardening PTFE Yarn

Chesterton 324 is a PTFE valve packing specially treated with protective lubricants. With 324's unique formulation and construction you can't squeeze out the lubricants. It will not harden, and it will not deteriorate in a wide range of chemical applications. Chesterton 324 is guaranteed for the life of the valve. If it doesn't outlast the valve it's in, we'll replace it for FREE.*



Product Reorder				
Size		Packaged ± 10%		Reorder Number
mm	Inch	kg	lbs	
3,0	1/8	0,908	2	003260
4,0	-	0,908	2	003261
5,0	3/16	0,908	2	003262
6,0	-	0,908	2	003263
6,5	1/4	0,908	2	032464
		2,270	5	032473
8,0	5/16	0,908	2	032465
		2,270	5	032474
9,5	3/8	0,908	2	032466
		2,270	5	032475
10,0	-	0,908	2	032467
11,0	7/16	2,270	5	032477
12,0	-	2,270	5	032478
12,5	1/2	0,908	2	032470
		2,270	5	032479
		4,540	10	032483
14,0	9/16	2,270	5	032480
16,0	5/8	4,540	10	032485
19,0	3/4	4,540	10	032487
22,0	7/8	4,540	10	032489
25,5	1	4,540	10	032494

- Excellent chemical resistance
- Non-hardening
- Guaranteed for the life of the valve

Technical Data

Temperature Limit:
260°C (500°F)

Pressure Limit:
170 bar g (2500 psig)

Chemical Resistance:
pH 0 to 14

Applications:
Valves handling steam, severe chemicals and solvents

*Contact your local Chesterton representative for a copy of the written guarantee.

401

Wire Reinforced Braided Yarn

Chesterton 401 is constructed with wire-reinforced braided yarn which surrounds a flexible and resilient asbestos-free core. The non-asbestos jacketed yarn construction encapsulates the wire reinforcement in the yarn, preventing stem wear and scoring. This special construction makes 401 an economical, non-asbestos, general service valve stem packing for use in high-temperature and high-pressure applications.

Product Reorder				
Size		Packaged ± 10%		Reorder Number
mm	Inch	kg	lbs	
6,5	1/4	0,908	2	005261
		2,270	5	005262
8,0	5/16	0,908	2	005263
		2,270	5	005271
9,5	3/8	0,908	2	005272
		2,270	5	005284
		4,540	10	005286
10,0	-	0,908	2	005307
		2,270	5	005320
11,0	7/16	0,908	2	005321
		2,270	5	005322
12,0	-	0,908	2	005323
		2,270	5	005324
12,5	1/2	0,908	2	005325
		2,270	5	005326
		4,540	10	005327
14,0	9/16	2,270	5	005328
		4,540	10	005329
16,0	5/8	4,540	10	005330
17,5	11/16	4,540	11	005331
19,0	3/4	4,540	10	005332
20,5	13/16	4,540	10	005333
22,0	7/8	4,540	10	005334
25,5	1	4,540	10	005335



- Economical, general service valve stem packing
- Wire-reinforced braid over core construction
- High-temperature, high-pressure service

Technical Data

Temperature Limit:
650°C (1200°F)

Pressure Limit:
105 bar g (1500 psig)

Chemical Resistance:
pH 1 to 12

Applications:
General service high-temperature, high-pressure valve sealing applications



FLANGE SEALING

- Live loading
- Semi-metallic gaskets
- Sheet/soft gaskets
- Tape gaskets

Live Loading

5500, 5505L, 5505H Flange Discs

Increase reliability, lower emissions, and reduce total costs by using tailored sealing solutions for critical flanges

Chesterton® Live Loading System

Chesterton Flange Live Loading increases flange reliability by increasing the elastic energy in the flange assembly. This ensures that a pre-calculated gasket stress is maintained at all times, regardless of pressure fluctuations, gasket thickness loss, or thermal cycles. Chesterton flange discs are specially designed for flange applications and maintain their flexibility under extreme mechanical and thermal conditions.

Technical Data	5500	5505L	5505H
Materials	Specialized stainless steel alloy	High strength, high temperature resistant and corrosion resistant stainless steel alloy	Chromium steel with oxide coating
Temperature	-200°C to 300°C (-328°F to 575°F)	-100°C to 350°C (-148°F to -662°F)	0°C to 600°C (32°F to 1100°F)
Corrosion resistance	good	good	average
Applications	Use in combination with Chesterton® Camprofile or Steel Trap™ gaskets on process flanges, heat exchangers, vessels, reactors, valve bonnets, housings, and sight glasses		
Warranty	3-year warranty (see flange live loading warranty for conditions)		

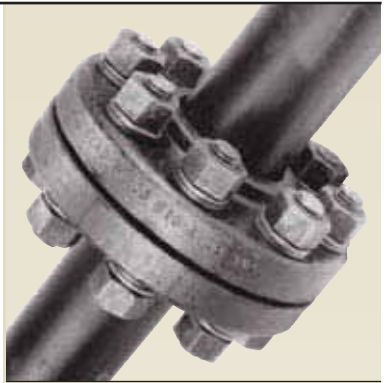

- Shut down to shut down reliability
- Significantly reduces downtime on critical equipment
- Lowers emissions and meets environmental regulations
- Reduces leakage and product loss
- Reduces safety and housekeeping concerns
- Improves plant efficiency and reduces total cost
- For bolted heat exchangers and pipe flanges
- Maintains constant compression on gasket seals
- Eliminates leakage problems caused by thermal cycling, vibration, and pressure surges
- High temperature capability



5500



5505L



5505H

Steel Trap™

High Performance, Semi-Metallic Gasket

Steel Trap is the preferred gasket when improved performance at a minimum seating stress is needed. It features fire, blow out, and leak proof benefits along with the sealing properties of an encapsulated element in a compression seal. Steel Trap is the ideal replacement for problem applications. Steel Trap is available in standard and custom designs, including the unique self-locating design.



Technical Data	
Materials	Metal carrier from virtually any metal with graphite, PTFE, or ceramic sealing elements
Temperature	Atmosphere –200°C to 500°C (–328°F to 932°F) Steam up to 650°C (1200°F) Inert media –200°C to 900°C (–328°F to 1650°F)
Pressure	415 bar g (6000 psig)
pH	0 to 14
Applications	Pipe flanges, heat exchangers, vessels, reactors, valve bonnets, housings

Applicable Standards and Approvals: TA-Luft

- Thin design and soft sealing material encapsulation provides increased blow out safety
- Replaces sheet gaskets without equipment modification
- Can be manufactured in virtually any shape

Spiral Wound

Economical, Semi-Metallic Gasket

Spiral Wound Gaskets are one of the most common metal gaskets used for flange sealing. Chesterton’s Spiral Wound Gaskets are manufactured in accordance with ASME B16.20 and DIN Standards, and are available in a wide range of alloys, sealing materials, sizes, and shapes for most flange applications and services.



Technical Data	
Materials	Stainless steel windings with graphite or PTFE sealing layer, stainless steel inner ring, coated carbon steel outer ring (more materials available)
Temperature	graphite sealing layer 550°C (1022°F) PTFE sealing layer 300°C (572°F)
Pressure	350 bar g (5075 psig)
pH	0 to 14
Applications	Pipe flanges, vessels, reactors, valve bonnets, housings

Applicable Standards and Approvals: TA-Luft

- Economical, semi-metallic solution
- DIN and ANSI standard gaskets and custom shapes available
- Various configurations

Camprofile

High Performance, Semi-Metallic Gasket

Chesterton’s Camprofile gaskets offer outstanding performance in emissions and industrial applications with virtually undetectable leakage. Testing at the MPA Stuttgart demonstrates the superior leak tightness of our Camprofile gaskets against competitive Camprofiles and the more commonly used spiral wound gaskets.



Technical Data	
Materials	Stainless steel carrier with a graphite or PTFE sealing element (more materials available)
Temperature	graphite sealing layer 550°C (1022°F) inert media -200°C to 900°C (-328°F to 1652°F) PTFE sealing layer 300°C (572°F)
Pressure	400 bar g (5800 psig)
pH	0 to 14
Applications	Pipe flanges, heat exchangers, vessels, reactors, valve bonnets, housings

Applicable Standards and Approvals: TA-Luft

- Certified low emission performance
- High reliability
- DIN and ANSI standard gaskets
- Custom shapes available, including heat exchanger gaskets

100

Red Rubber

Chesterton 100 is a quality styrene butadiene rubber sheet compounded to remain soft and pliable with smooth surfaces. 100 is particularly suitable for air, hot and cold water, and saturated steam.



Product Reorder							
Thickness		Weights ± 10%		Approximate Weight Per Roll		Yds. Per Roll ± 10%	Reorder Number
mm	Inch	kg/m ²	lbs per yd	mm (W) x kg	Inches (W) x lbs		
1,6	1/16	2,4	4,8	914 x 45	36 x 100	21	010001
2,4	3/32	3,5	7,1	914 x 45	36 x 100	14	010066
3,2	1/8	4,5	9,1	914 x 45	36 x 100	11	010002
4,8	3/16	7,1	14,3	914 x 45	36 x 100	7	010003
6,4	1/4	9,9	20	914 x 45	36 x 100	5	010004

Technical Data

Temperature Limit:
80°C (180°F) maximum
-29°C (-20°F) minimum

Pressure Limit:
17 bar g (250 psig)

Durometer:
70 to 85 Shore A

Surface Finish: Smooth

Color: Red

119

Cloth Inserted Rubber

Chesterton 119 is a styrene butadiene rubber, polyester cloth-inserted sheet of high strength, rendering it adaptable to light hydraulic service. The cloth is inserted on the inside protecting both sides with a rubber cover. It may be used in hot or cold water, low pressure steam, or ammonia.



Product Reorder					
Thickness		Approximate Weight Per Roll		Yds. Per Roll ± 10%	Reorder Number
mm	Inch	mm (W) x kg	Inches (W) x lbs		
1,5	1/16	914 x 45	36 x 100	23	011901
2,4	3/32	914 x 45	36 x 100	15	011966
3,0	1/8	914 x 45	36 x 100	12	011902
5,0	3/16	914 x 45	36 x 100	8	011903
6,5	1/4	914 x 45	36 x 100	6	011904

Technical Data

Temperature Limit:
80°C (180°F)

Pressure Limit:
10 bar g (150 psig)

Tensile Strength:
69 bar g (1000 psig) minimum

Durometer:
70 to 85 Shore A

Surface Finish: Smooth

Color: Black

122NN

Diaphragm

Chesterton 122NN is a superior quality black diaphragm sheet. For use in services where a high strength nylon fabric reinforced sheet will produce the best results. 122NN's neoprene rubber construction delivers excellent service in steam, gas, air, oil, water, and solvents. 122NN can be used on regulators, reducing valve actuators, or any diaphragm service.

Product Reorder									
Thickness		Width		Weight Per Roll*		Length Per Roll*			Reorder Number
mm	Inch	mm	Inch	kg	lbs	Meters	Yds	Feet	
1,6	1/16	1422	56	46,8	104.0	15,2	16.7	50.0	012210
3,2	1/8	1422	56	46,8	104.0	7,6	8.3	25.0	012282
4,8	3/16	1422	56	56,3	125.0	6,1	6.7	20.0	012213
6,4	1/4	1422	56	56,3	125.0	4,6	5.0	15.0	012212

*Nominal



Technical Data

Temperature Limit:

93°C (200°F) maximum
-40°C (-40°F) minimum

Pressure Limit:

17 bar g (250 psig)
3,2 mm (1/8") thick

Tensile Strength:

97 bar g (1400 psig) minimum

Elongation: 300% minimum

Durometer: 65 to 75 Shore A

Width: 122 +/- 2,5 cm (48", +/- 1")
Meets ASTM D2000 BC714

Mullen Burst Test Rating:

83 bar g (1200 psig), obtained using burst tester with 31,5 mm (1.24") diameter opening per ASTM D751 and 1 ply material

Surface Finish: Smooth

Color: Black

124

Oil Resistant Rubber

Chesterton 124 rubber sheet is made of oil resistant materials and a fortified carbon black compound for gaskets against fatty acids, oils, water, low pressure steam, solvents, and non-aromatic petroleum products.

Product Reorder					
Thickness		Approximate Weight Per Roll		Yds Per Roll ± 10%	Reorder Number
mm	Inch	mm (W) x kg	Inches (W) x lbs		
1,6	1/16	914 x 45	36 x 100	24	012401
3,2	1/8	914 x 45	36 x 100	12	012402
4,8	3/16	914 x 45	36 x 100	8	012403
6,4	1/4	914 x 45	36 x 100	6	012404



Technical Data

Temperature Limit:

88°C (190°F) maximum
-29°C (-20°F) minimum

Durometer:

55 to 65 Shore A

Surface Finish: Smooth

Color: Black

184

Expanded PTFE

Chesterton 184 is 100% virgin PTFE with micro-fibrillated internal structure for excellent stability. Micro-fibrillated structure turns ordinary PTFE into a dimensionally strong, creep resistant gasket material. 184 provides a long lasting, high reliability seal with minimum re-torque requirements. 184 is soft and pliable to conform to worn or uneven surfaces and effects a tight seal.

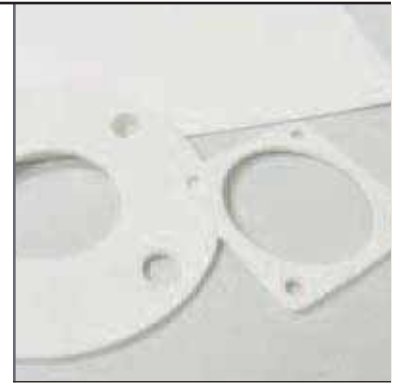

Product Reorder				
Size		Dimensions		Reorder Number
mm	Inch	M	Inch	
1,6	1/16	1,52 x 1,52	60 x 60	004843
3,2	1/8	1,52 x 1,52	60 x 60	004844

Technical Data

Temperature Limit:
-267°C (-450°F) to 315°C (600°F)

Pressure Limit:
Full vacuum to 210 bar g (3000 psig)

Chemical Resistance:
pH 0 to 14 inert to all common chemicals except molten alkali metals and elemental fluorine

Applications:
For large areas and cut gasketing

Color: White

195

Synthetic Fiber

Chesterton 195 synthetic fiber, nitrile binder sheet is a heavy duty sheet consisting of aramid fibers and high quality nitrile binder. Applicable for use in a wide range of general service flange gasket applications.



Product Reorder						
Size		Dimensions		Packaged ± 10%		Reorder Number
mm	Inch	M	Inch	kg	lbs	
0,4	1/64	1,52 x 1,52	60 x 60	1,4	3.8	019561
0,8	1/32	1,52 x 1,52	60 x 60	2,7	7.6	019562
1,6	1/16	1,52 x 1,52	60 x 60	5,4	15.0	019501
2,4	3/32	1,52 x 1,52	60 x 60	8,2	23.0	019586
3,2	1/8	1,52 x 1,52	60 x 60	10,9	30.0	019502
0,8	1/32	1,52 x 3,04	60 x 120	5,4	15.0	019574
1,6	1/16	1,52 x 3,04	60 x 120	10,9	30.0	019571
2,4	3/32	1,52 x 3,04	60 x 120	16,3	46.0	019576
3,2	1/8	1,52 x 3,04	60 x 120	21,8	60.0	019572

Technical Data

Temperature Limit:
400°C (750°F)

Pressure Limit:
100 bar g (1470 psig),
20 bar g (300 psig) saturated steam service

P x T = 14,400 (°C x bar g)

P x T = 400,000 (°F x psig)

Color: White

198

Inhibited Graphite

Chesterton 198 is a high purity graphite sheet with no fillers or binders. 198 contains a corrosion inhibitor, making it an excellent gasket for almost all environments—ideal for use in extreme temperature applications where metal reinforcement cannot be used.



Product Reorder						
Thickness		Dimensions Length x Width		Approximate Weight		Reorder Number
mm	Inch	M	Inch	kg	lbs	
0,8	1/32	1,00 x 1,00	39.4 x 39.4	0,86/1,28	1.89/2.83	014011
1,6	1/16	1,00 x 1,00	39.4 x 39.4	1,71/2,14	3.77/4.72	014012
3,2	1/8	1,00 x 1,00	39.4 x 39.4	3,42/3,85	7.54/8.49	014013
0,8	1/32	1,52 x 1,52	60 x 60	1,98/2,95	4.38/6.51	014014
1,6	1/16	1,52 x 1,52	60 x 60	3,97/4,94	8.75/10.88	014015
3,2	1/8	1,52 x 1,52	60 x 60	7,94/8,90	17.50/19.63	014016
2,0	–	1,00 x 1,00	39.4 x 39.4	2,79	6.15	014017
2,5	–	1,00 x 1,00	39.4 x 39.4	2,88	6.35	014018
1,0	–	1,00 x 1,00	39.4 x 39.4	1,18	2.59	014019

Technical Data

Temperature Limit:

–240°C (–400°F) to 2760°C (5000°F) in non-oxidizing services
455°C (850°F) in oxidizing services

Pressure Limit:

140 bar g (2000 psig),

Compressibility (ASTM-F36)
40%

Creep Relaxation (ASTM-F38)
<5%

Recovery (ASTM-F36)
12 to 17%

P x T = 58,000 (°C x bar g)

P x T = 1,600,000 (°F x psig)

Color: Grey

199

Foil Inserted Inhibited Graphite

Chesterton 199 is a high purity, chemically inert graphite sheet with a 316 stainless steel foil insert for extreme stability. 199 contains a corrosion inhibitor to prevent galvanic attack of flange faces. Its excellent thermal stability, chemical resistance, and negligible creep characteristics make it a truly universal sheet gasket.



Product Reorder						
Thickness		Dimensions Length x Width		Approximate Weight		Reorder Number
mm	Inch	M	Inch	kg	lbs	
2,0	–	1,00 x 1,00	39.4 x 39.4	2,79	6.15	014020
0,8	1/32	1,00 x 1,00	39.4 x 39.4	0,86/1,28	1.89/2.83	014021
1,6	1/16	1,00 x 1,00	39.4 x 39.4	1,71/2,14	3.77/4.72	014022
3,2	1/8	1,00 x 1,00	39.4 x 39.4	3,42/3,85	7.54/8.49	014023
0,8	1/32	1,52 x 1,52	59.1 x 59.1	1,98/2,95	4.38/6.51	014024
1,6	1/16	1,52 x 1,52	59.1 x 59.1	3,97/4,94	8.75/10.88	014025
3,2	1/8	1,52 x 1,52	59.1 x 59.1	7,94/8,90	17.50/19.63	014026
2,5	–	1,00 x 1,00	39.4 x 39.4	2,88	6.35	014029
1,6	1/16	1,52 x 3,05	59.1 x 120	6,94	15.31	014030
2,6	–	1,5 x 1,5	–	6,75	14.87	014035
3,2	1/8	1,52 x 3,05	59.1 x 120	13,26	29.25	014036
5,0	3/16	1,00 x 1,00	39.4 x 39.4	5,44	12.0	014010
1,6	1/16	1,52 x 2,43	59.1 x 96	6,35	12.0	014038
2,4	–	1,00 x 1,00	39.4 x 39.4	2,66	5.88	014034

Technical Data

Temperature Limit:

870°C (1600°F) in non-oxidizing services
455°C (850°F) in oxidizing services

Pressure Limit:

140 bar g (2000 psig)

Compressibility (ASTM-F38)
40%

Creep Relaxation (ASTM-F38)
<5%

Recovery (ASTM-F36)
12 to 17%

P x T = 58,000 (°C x bar g)

P x T = 1,600,000 (°F x psig)

Color: Grey

359

Graphite

Chesterton 359 is a cost effective, general purpose graphite sheet reinforced with a 304 stainless steel foil insert. Its excellent chemical resistance and thermal stability make this sheet a superior alternative to compressed fiber sheet gasket for virtually all applications in the plant.



Product Reorder				
Thickness		Dimensions		Reorder Number
mm	Inch	M	Inch	
0,75	1/32	1,00 x 1,00	39.4 x 39.4	153793
1,0	–	1,00 x 1,00	39.4 x 39.4	153794
1,5	1/16	1,00 x 1,00	39.4 x 39.4	153795
2,0	–	1,00 x 1,00	39.4 x 39.4	153796
3,2	1/8	1,00 x 1,00	39.4 x 39.4	153797

Technical Data

Temperature Limit:
 870°C (1600°F) in non-oxidizing services
 455°C (850°F) in oxidizing services

Pressure Limit:
 140 bar g (2000 psig),

Compressibility: 35 to 50%

Recovery: 10 to 15% minimum

Color: Grey

450

Synthetic Fiber

Chesterton 450 Synthetic Fiber Sheet is a low temperature, gasket material suitable for general services to 200°C (390°F). 450 Synthetic Fiber Sheet is recommended for use in water, gas, brine, and steam applications. 450 is not recommended for use in chlorinated hydrocarbons or aromatic and ester ketones.



Product Reorder				
Thickness		Dimensions		Reorder Number
mm	Inch	M	Inch	
0,4	1/64	1,52 x 1,52	60 x 60	003050
0,8	1/32	1,52 x 1,52	60 x 60	003051
1,6	1/16	1,52 x 1,52	60 x 60	003052
2,4	3/32	1,52 x 1,52	60 x 60	003053
3,2	1/8	1,52 x 1,52	60 x 60	003054

Technical Data

Temperature Limit:
 200°C (390°F)

Pressure Limit:
 25 bar g (365 psig)

Compressibility (ASTM-F36):
 7 to 17%

Sealability (ASTM-F37):
 0,25 ml/hr

Creep relaxation (ASTM-F38):
 20% maximum

Recovery (ASTM-F36):
 40% minimum

Tensile strength across grain (ASTM-F152)
 110 bar g (1600 psig)

P x T = 4,375 (°C x bar g)
P x T = 125,000 (°F x psig)

Color: Green

455

Aramid Fiber

Chesterton 455 Aramid Fiber Sheet with Nitrile Binder is a general purpose sheet gasket material offering good sealability and chemical resistance. 455 incorporates synthetic fiber with a nitrile binder and can be used against water, salt solutions, organic alkali aliphatic and aromatic hydrocarbons, alcohols, ester, oils, and gases up to 300°C (575°F). 455 is not recommended for use in chlorinated hydrocarbons, aromatic and ester ketones.



Product Reorder				
Thickness		Dimensions		Reorder Number
mm	Inch	M	Inch	
0,4	1/64	1,52 x 1,52	60 x 60	003630
0,8	1/32	1,52 x 1,52	60 x 60	003631
1,6	1/16	1,52 x 1,52	60 x 60	003632
2,4	3/32	1,52 x 1,52	60 x 60	003633
3,2	1/8	1,52 x 1,52	60 x 60	003634
3,2	1/8	1,52 x 4,56	60 x 180	003643
1,6	1/16	1,52 x 4,56	60 x 180	003644

Technical Data

Temperature Limit:
300°C (575°F)

Pressure Limit:
50 bar g (735 psig)

Compressibility (ASTM-F36):
7 to 17%

Sealability (ASTM-F37):
0,25 ml/hr

Creep relaxation (ASTM-F38):
25% maximum

Recovery (ASTM-F36):
50% minimum

Tensile strength across grain (ASTM-F152):
100 bar g (1500 psig)

P x T = 12,810 (°C x bar g)
P x T = 350,000 (°F x psig)

Color: Light Red

457

Carbon Fiber

Chesterton 457 Carbon Fiber Sheet with Nitrile Binder is a high temperature sheet gasket material formulated for a wide variety of applications. 457 is recommended for use in a broad range of steam, water, oil and hydrocarbon applications. 457 is not recommended for use in chlorinated hydrocarbons, aromatic and ester ketones.



Product Reorder				
Thickness		Dimensions		Reorder Number
mm	Inch	M	Inch	
0,4	1/64	1,52 x 1,52	60 x 60	003851
0,8	1/32	1,52 x 1,52	60 x 60	003852
1,6	1/16	1,52 x 1,52	60 x 60	003853
2,4	3/32	1,52 x 1,52	60 x 60	003854
3,2	1/8	1,52 x 1,52	60 x 60	003855

Technical Data

Temperature Limit:
450°C (840°F)

Pressure Limit:
100 bar g (1470 psig)

Compressibility (ASTM-F36):
5 to 15%

Sealability (ASTM-F37):
0,30 ml/hr

Creep relaxation (ASTM-F38):
30% maximum

Recovery (ASTM-F36):
50% minimum

Tensile strength across grain (ASTM-F152):
100 bar g (1500 psig)

P x T = 21,800 (°C x bar g)
P x T = 600,000 (°F x psig)

Color: Black

459

Graphite

Chesterton 459 graphite sheet with a nickel foil reinforcement is designed for use in high temperature, high pressure flange applications. The nickel foil makes 459 easier to cut than other reinforced gasket sheets. It has excellent chemical resistance and can be used up to 870°C (1600°F) in a non-oxidizing atmosphere.



Product Reorder				
Thickness		Dimensions		Reorder Number
mm	Inch	M	Inch	
0,8	1/32	1,00 x 1,00	39.4 x 39.4	005038
0,5	–	1,00 x 1,00	39.4 x 39.4	005042
1,0	–	1,00 x 1,00	39.4 x 39.4	005043
1,6	1/16	1,00 x 1,00	39.4 x 39.4	005039
2,0	–	1,00 x 1,00	39.4 x 39.4	005044
3,0	1/8	1,00 x 1,00	39.4 x 39.4	005040
2,4	3/32	1,00 x 1,00	39.4 x 39.4	005050

Technical Data

Temperature Limit:
 870°C (1600°F) non-oxidizing
 450°C (850°F) oxidizing

Pressure Limit:
 140 bar g (2000 psig)

Compressibility (ASTM-F36)
 35% minimum

Creep relaxation (ASTM-F38):
 <5% maximum

Recovery (ASTM-F36):
 10% minimum

P x T = 60,000 (°C x bar g)
P x T = 1,600,000 (°F x psig)

Color: Grey

553

Environmental Sheet

Chesterton 553 is a supreme fiber gasket produced from a combination of aramid fibers, glass and specialty fillers and rubber binders. The 553 offers superior performance in high temperature and high pressure applications. The 553 sheet gasket is has a DVGW and KTW approval and is fire safe according to API 607.



Product Reorder				
Thickness		Dimensions		Reorder Number
mm	Inch	M	Inch	
0,5	–	1,52 x 1,52	60 x 60	335327
0,6	–	1,52 x 1,52	60 x 60	335328
0,8	1/32	1,52 x 1,52	60 x 60	335329
1,0	–	1,52 x 1,52	60 x 60	335330
1,5	1/16	1,52 x 1,52	60 x 60	335331
2,0	–	1,52 x 1,52	60 x 60	335332
2,4	3/32	1,52 x 1,52	60 x 60	335333
3,0	–	1,52 x 1,52	60 x 60	335334
3,2	1/8	1,52 x 4,56	60 x 180	335335

Technical Data

Temperature Limit:
 450°C (842°F) maximum service
 250°C (482°F) maximum continuous operating

Pressure Limit:
 120 bar g (1740 psig) maximum service
 40 bar g (580 psig) maximum continuous operating

Compressibility (ASTM F-36):
 6 to 12%

Creep Relaxation (ASTM F-38):
 8% maximum

Recovery (ASTM F-36): 55% minimum

Tensile Strength (ASTM F-152):
 9 Mpa (1305 psig) (DIN 52910)

Color: Green

ECS

Environmental Containment Sheet (ECS) ECS-W, ECS-T, ECS-B

ECS-W is a white PTFE sheet gasket suitable for general service in a wide variety of fluids, strong caustics, acids, chlorine, gases, water, steam, hydrocarbons, hydrogen, and aluminum fluoride.

ECS-T is an orange PTFE sheet gasket material suitable for high pressure and temperature services, especially in chemical and hydrocarbon plants in strong acids.

ECS-B is a blue FDA-approved structured PTFE sheet gasket suitable for chemically aggressive services. It is recommended for services with water, steam hydrocarbons, hydrogen peroxide, solvents, refrigerants, cryogenic products, caustics, and strong acids.



Technical Data

Temperature Limit:
-210°C (-346°F) to 260°C (500°F)

Pressure Limit:
ECS-W and *ECS-T*: 83 bar g (1200 psig)
ECS-B: 55 bar g (800 psig)

Chemical Resistance:
pH 0 to 14 inert to all common chemicals except molten alkali metals, fluorine and certain fluorine bearing compounds.

Sealability (ASTM F-37A) @ .7 bar g:

ECS-W: 0,04 ml/h
ECS-T: 0,20 ml/h
ECS-B: 0,12 ml/h

Compressibility (ASTM F-36A) @ 5000 psig:

ECS-W: 5 to 15%
ECS-T: 7 to 12%
ECS-B: 30 to 50%

Sealability (DIN 3535):
< 0,015 cm³/min

Creep Relaxation (ASTM F-38B):

ECS-W: 25% maximum
ECS-T: 18% maximum
ECS-B: 40% maximum

Recovery (ASTM F-36A) @ 5000 psig:

ECS-W and *ECS-T*: 40% minimum
ECS-B: 25% minimum

Tensile Strength (ASTM F-152):
2000 psig; (14 MPa)

P x T Factor:

12,000 (°C x bar g)
350,000 for 1/16"; (°F x psig)
8,500 (°C x bar g)
250,000 for 1/8"; (°F x psig)

Product Reorder						
Thickness		Dimensions		ECS-W Reorder Number	ECS-T Reorder Number	ECS-B Reorder Number
mm	Inch	M	Inch			
0,8	1/32	1,19 x 1,19	47 x 47	058100	058109	058091
1,5	-	1,5 x 1,5	59 x 59	058106	058115	058097
1,6	1/16	1,5 x 1,5	59 x 59	058099	058108	058090
2,0	-	1,5 x 1,5	59 x 59	058107	058116	058098
2,4	3/32	1,5 x 1,5	59 x 59	058103	058112	058094
3,2	1/8	1,5 x 1,5	59 x 59	058102	058111	058093
FDA Sheets						
0,8	1/32	1,19 x 1,19	47 x 47	058125	058132	058118
1,5	-	1,5 x 1,5	59 x 59	058129	058136	058122
1,6	1/16	1,5 x 1,5	59 x 59	058124	058131	058117
2,0	-	1,5 x 1,5	59 x 59	058130	058137	058123
2,4	3/32	1,5 x 1,5	59 x 59	058127	058134	058120
3,2	1/8	1,5 x 1,5	59 x 59	058126	058133	058119

165

Graphite Joint Sealant

Chesterton 165 Ultraseal features advanced materials for tight jointed connections. This exclusive joint sealant is constructed using graphite reinforced with an Inconel® wire mesh covering on a self-adhesive backing. 165 provides the high temperature, high pressure performance of a graphite sheet on a roll for fast and easy use. Lay out complex shapes fast with spooled Joint Sealant, eliminating waste from cut sheet.

Product Reorder				
Size		Approximate Length		Reorder Number
mm	Inch	M	Feet	
3,2	1/8	15	50	003209

Inconel® is a registered trademark of Special Metals Corporation.

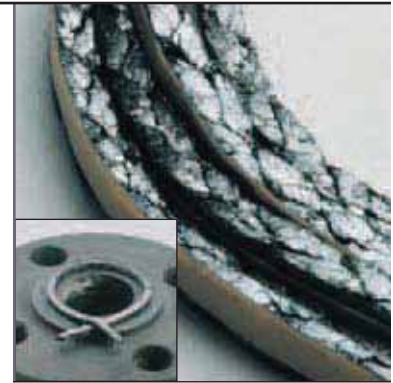

Technical Data

Temperature Limit:
650°C (1200°F) steam
455°C (850°F) oxidizing environment

Pressure Limit:
140 bar g (2000 psig)

Chemical Resistance:
pH 0 to 14 inert to all chemicals

Applications:
For high pressure, high temperature flange sealing services.

175

Silicon Foam

Chesterton 175 Peel&Seal™ silicone foam gasket puts a high quality gasket in your toolbox. Just lay out the path for the gasket, peel off the adhesive paper backing, and apply. The aggressive adhesive is specially designed to hold in place for bolt tightening, but is easily removed.

- Faster than cut rubber gaskets
- Cleaner and easier than two-part, form-in-place and spray can gaskets
- Complete inventory of gaskets on a roll
- Closed-cell foam forms and compresses better than solid silicone rubber
- No binders, no fillers, no leak paths
- More economical than PTFE joint sealants and just as convenient

Product Reorder				
Size		Approximate Length		Reorder Number
mm	Inch	M	Feet	
9,5	3/8	7,6	25	000558
12,5	1/2	7,6	25	000559
19,0	3/4	7,6	25	000561
25,5	1	7,6	25	000562

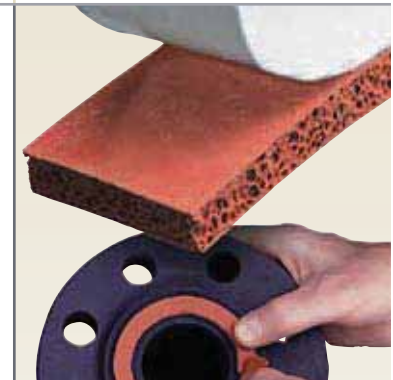

Technical Data

Temperature Limit:
180°C (350°F)

Pressure Limit:
15 bar g (200 psig)

Chemical Resistance:
It can be used in many chemicals, lubricating oils, and alcohols.

Diluted acids and alkalis have little effect on the performance of this material.

Applications:
For use on flanges, manway and handway covers, electric motor junction boxes; NEMA 12 and 4 control panel.

Door gaskets, HVAC duct covers.

185

Expanded PTFE Joint Sealant

Chesterton 185 Expanded Form-In-Place Spooled Joint Sealant is 100% virgin PTFE with micro-fibrillated internal structure for excellent stability. Micro-fibrillated structure turns ordinary PTFE into a dimensionally strong, creep resistant gasket material. 185 provides a long lasting, high reliability seal with minimum re-torque requirements. 185 is soft and pliable to conform to worn or uneven surfaces. It is fast and easy to use. Lay out complex shapes fast with 185 Expanded PTFE Spooled Joint Sealant, eliminating waste from cut sheet. Self-adhesive strip holds the joint sealant in place for easy assembly in the shop or in the field.



- Superior sealability, even on worn or uneven flange surfaces
- Long lasting, high reliability seal with minimum re-torque requirements
- Fast and easy to use
- Suitable for food grade applications FDA 21CFR 77.1550

Product Reorder				
Size Width		Size Length		Reorder Number
mm	Inch	M	Feet	
1,0	-	30,0	100	004819
		305,0	1000	004820
3,0	1/8	30,0	100	004821
		305,0	1000	004822
5,0	3/16	23,0	75	004823
		230,0	750	004824
6,5	1/4	15,0	50	004825
		152,0	500	004826
9,5	3/8	7,5	25	004827
		15,0	50	004828
		76,0	250	004829
12,5	1/2	4,5	15	004830
		9,0	30	004831
		45,0	150	004832
16,0	5/8	4,5	15	004833
		9,0	30	004834
		45,0	150	004835
19,0	3/4	4,5	15	004836
		9,0	30	004837
		30,0	100	004838
25,5	1	4,5	15	004839
		9,0	30	004840
		23,0	75	004841
51,0	2	12,0	39	004842

Technical Data

Temperature Limit:

-270°C (-450°F) to 315°C (600°F)

Pressure Limit:

Full vacuum to 210 bar g (3000 psig)

Chemical Resistance:

pH 0 to 14 inert to all common chemicals, except molten alkali metals and elemental fluorine

Applications:

Fume ducts, steam vessel flanges, concrete lids, manways, glass joints, ceramic joints, heat exchangers, water systems, hydraulic and pneumatic systems, fiberglass reinforced plastic vessels, pump or compressor housing flanges, or practically any other industrial equipment where you require a long-life, trouble-free seal that cuts maintenance costs



185 PTFE Joint Sealant Kit
Reorder No. 004801

Kit includes four spool sizes:
5 mm (3/16"), 6,5 mm (1/4"),
9,5 mm (3/8") and 12,5 mm (1/2")

Fiberglass Products

Chesterton’s line of fiberglass products (160, 161, 162, and 289) for gasket sealing, wrapping, insulating, and protecting in a broad variety of industrial and marine applications. This product line offers many unique characteristics and advantages including flexibility, dimensional stability, and high tensile strength.



160 Fiberglass Tape

Product Reorder					
Sizes		Length per Roll		lbs/100'	Reorder Number
mm	Inch	M	Feet		
1,6 x 25,4	1/16 x 1	30,5	100	2.0	001601
1,6 x 50,8	1/16 x 2	30,5	100	4.1	001602
1,6 x 76,2	1/16 x 3	30,5	100	6.1	001603
3,2 x 25,4	1/8 x 1	30,5	100	4.2	001604
3,2 x 38,1	1/8 x 1-1/2	30,5	100	6.2	001607
3,2 x 50,8	1/8 x 2	30,5	100	8.1	001605
3,2 x 76,2	1/8 x 3	30,5	100	12.2	001606

Technical Data

Temperature Limit:
540°C (1000°F)

Elongation:
3% maximum

Flammability:
Non-flammable

Chemical Incompatibilities:
Hydrofluoric acid, hot phosphoric acid, and wet hydrogen chloride

161 Fiberglass Rope

Product Reorder						
Size		Packaged ± 10%				Reorder Number
mm	Inch	kg	lbs	M/kg	ft/lb	
6,4	1/4	11,4	25	37	55	016104
7,9	5/16	11,4	25	30,9	46	016103
9,5	3/8	11,4	25	16,5	24.5	016106
12,7	1/2	11,4	25	9,1	13.5	016108
15,9	5/8	11,4	25	6,1	9	016110
19,1	3/4	11,4	25	4,4	6.5	016112
22,2	7/8	11,4	25	3,0	4.5	016114
25,4	1	11,4	25	2,5	3.7	016116
31,8	1 - 1/4	11,4	25	1,8	2.7	016120
38,1	1 - 1/2	11,4	25	1,4	2.1	016124
50,8	2	11,4	25	0,8	1.2	160132

Technical Data

Temperature Limit:
540°C (1000°F)

Elongation:
3% maximum

Flammability:
Non-flammable

Chemical Incompatibilities:
Hydrofluoric acid, hot phosphoric acid, and wet hydrogen chloride

162 Fiberglass Cloth

Product Reorder						
Thickness		Width		Length per Roll		Reorder Number
mm	Inch	M	Inch	M	Yds	
1,6	1/16	1,02	40	45,7	50	016201

Technical Data

Temperature Limit:
540°C (1000°F)

289 Fiberglass Tape

Product Reorder				
Thickness		Width		Reorder Number
mm	Inch	mm	Inch	
19,1	3/4	63,5	2 – 1/2	003750
22,2	7/8	25,4	1	003751
22,2	7/8	31,7	1 – 1/4	003752
22,2	7/8	63,5	2 – 1/2	003754
22,2	7/8	47,6	1 – 7/8	003753
25,4	1	28,6	1 – 1/8	003755
25,4	1	31,7	1 – 1/4	003756
25,4	1	63,5	2 – 1/2	003757
50,8	2	76,2	3	003780

Technical Data

Temperature Limit:
204°C (400°F)

Pressure Limit:
12,4 bar g (180 psig)

Chemical Resistance:
pH 4 to 9

Chemical Incompatibilities:
Hydrofluoric acid, hot phosphoric acid and wet hydrogen chloride

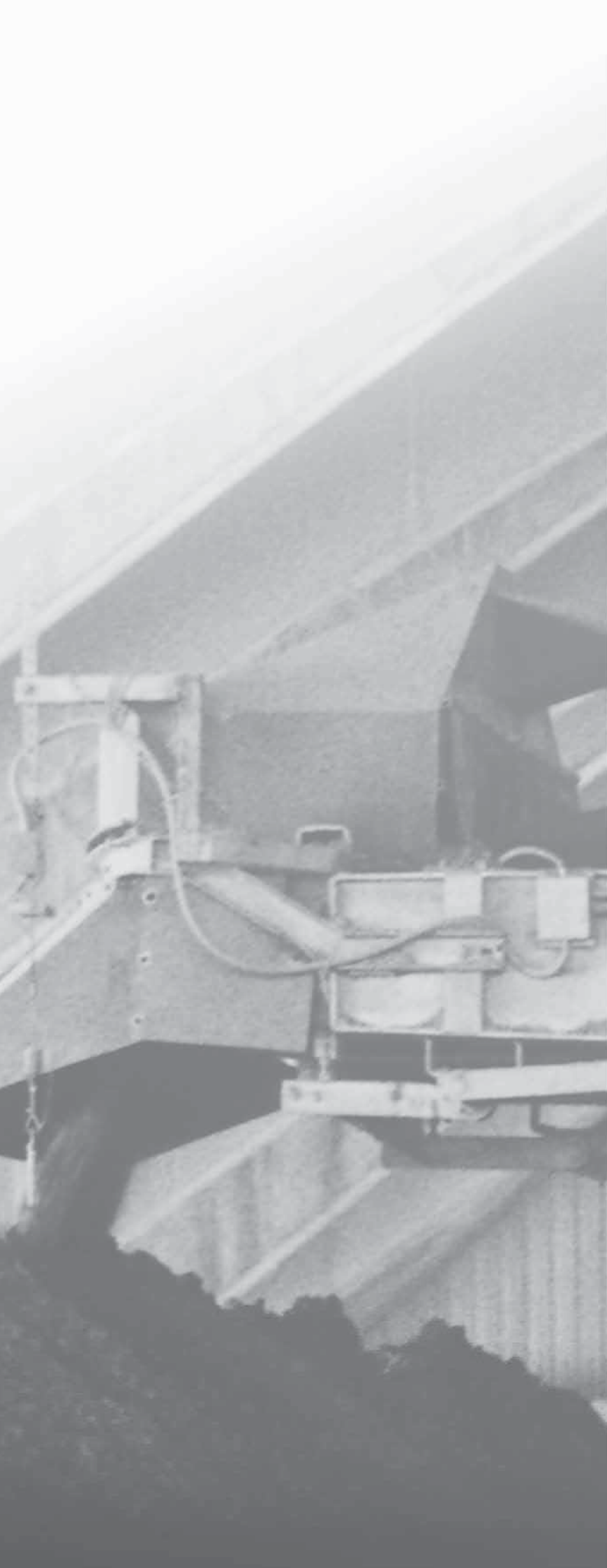

SPECIALTY EQUIPMENT

- Sootblower seals
- Tank covers, hatches, and lids

Lid-Lock

PTFE-Based Packing

Chesterton’s Lid-Lock packing is designed specifically to handle the unique sealing requirements of the tank covers, hatches and lids found on marine- and rail-based chemical transport equipment. In an industry where the variety of cargoes being shipped can vary on a frequent basis, it is important to have a universally compatible product sealing the tank lids.

The Lid-Lock starts with a rubber core overwrapped with a high quality PTFE film. This core is then overbraided with the non-absorbent, chemically resistant polypropylene yarn. The combination of the two gives this packing its excellent compressibility and elasticity. This flexible core is then wrapped with a double layer of high quality PTFE film. Finally, the Lid-Lock is overbraided with a tough, pure PTFE filament jacket that protects the PTFE film barrier from damage.



- PTFE-based construction makes it impervious to almost all chemicals
- Soft and conformable, yet resilient design provides excellent sealability and durability to withstand repeated tank cover opening and closing
- Available in bulk lengths or preformed, endless rings

Product Reorder	
Size (Bulk Length)	Reorder Number
mm	
25	087750
30	087751
38	087752
40	087753

Technical Data

Temperature Limit:
100°C (210°F)

Chemical Resistance:
pH 0 to 14

Applications:
Tank covers, hatches and lids found in marine- and rail-based chemical transport equipment

3000

Sootblower Sets

Chesterton 3000 Soot Blower Sets are molded from an exclusive mixture containing graphite and PTFE along with other materials. 3000 sets are designed with a thicker than usual top ring to act as a bearing for the set and to resist extrusion. All rings are split to go over the rod without being deformed. Exclusive Chesterton formulation and processing allow rings to slip over rod and return to their molded contour without cracking.

Sealing rings are designed so the top of each ring protects the ring above it. This eliminates the majority of lip damage normally associated with early set failure. Sealing ring lips expand inward and outward as increased gland pressure is applied. The tapered lip design allows the rings to respond readily to steam pressure, assuring increased sealing efficiency and longer life during operation. Individual sealing rings expand under bolt loading to maintain a tight, virtually leak-proof set with up to 50% longer service over braided styles.

- **Exclusive materials provide resilient, self-lubricating, extrusion resistant sets**
- **Resilient tapered lips for positive sealing**
- **Bendable cut rings for easy installation**
- **Up to 50% longer life than braided sets, no braided material to wear out or fray away**

Product Reorder			
ID mm	OD mm	Cross Section	Reorder Number
42	62	35	014710
42	62	50	008814
42	62	60	008813
42	62	70	008917
42	62	127	008918
48	68	50	008815
50	70	65	014727
60	80	60	008940
60	80	80	008857
60	80	90	008911
60	80	100	014702
60	80	110	008816

3000 Sootblower Product Reorder			
ID Inch	OD Inch	Cross Section	Reorder Number
0.5	1	1.25	008858
0.5	1.125	1.25	008912
1.25	2.5	2	008862
1.56	2.81	1.75	008950
1.625	2.187	2.5	008874
1.875	2.5	2.812	008841
1.875	2.5	2.875	008838
1.875	2.5	3	008905
1.875	2.5	3.062	008882
1.875	2.5	3.125	008839
1.875	2.625	2.25	008829
1.875	2.625	4.25	008832
1.875	2.625	4.875	008860
1.875	2.625	5	008866
1.96	2.715	2.2	008824
1.96	2.715	2.25	008823
1.96	2.715	2.5	008820
1.96	2.715	3.125	008923
2	2.625	1.625	008909
2	2.75	2.5	008873
2	2.75	3.187	014706
2	2.75	4	014719
2.25	3	4.75	008944
2.312	3.062	2	008855
2.312	3.062	2.125	008854
2.312	3.062	2.5	008852
2.312	3.062	3	008853
2.355	3	1.625	014704
2.355	3	1.875	008865
2.355	3	3.187	008864
2.355	3.125	3	014723
2.375	3	1	008869
2.375	3	1.375	008861
2.375	3	1.5	008806
2.375	3	1.562	008812
2.375	3	1.625	008850
2.375	3	1.75	008809
2.375	3	1.875	008870
2.375	3	2.25	008891

3000 Sootblower Product Reorder			
ID Inch	OD Inch	Cross Section	Reorder Number
2.375	3	2.875	008807
2.375	3	3	008808
2.375	3	3.125	008811
2.375	3	3.187	008851
2.375	3	3.25	008810
2.375	3	3.5	008901
2.375	3	3.625	008849
2.375	3	3.75	008877
2.375	3	3.875	008903
2.375	3.125	1.5	008847
2.375	3.125	1.625	008893
2.375	3.125	2	008900
2.375	3.125	2.25	008932
2.375	3.125	2.5	008848
2.375	3.125	3	008805
2.375	3.125	3.125	008804
2.375	3.125	3.187	008843
2.375	3.125	3.25	008803
2.375	3.125	3.375	008801
2.375	3.125	3.415	008842
2.375	3.125	3.5	008802
2.375	3.125	3.75	008844
2.375	3.125	4	008895
2.375	3.125	4.125	008952
2.375	3.125	4.25	008949
2.375	3.125	4.5	008878
2.375	3.125	6	008948
2.605	3.125	3	008915
2.75	3.5	1.625	014715
2.75	3.5	2.362	014712
2.75	3.5	3.125	008888
2.75	3.5	3.25	008907
2.75	3.5	3.375	014771
2.75	3.5	3.375	008827
2.75	3.5	3.5	008826
3.715	5	3.75	008835
3.75	5	3.75	008879
3.75	5	4.125	008825



Technical Data

Temperature Limit:
260°C (500°F)

Chemical Resistance:
pH 0 to 14

Applications:
Water, steam, acids and alkalis, solvents, and gases

5700/5700B

Sootblower Kits

The 5700/5700B Sootblower Kit combines Chesterton exclusive materials to seal the stuffing box. 5700/5700B Sootblower Kits include 5300 GTP sealing rings, 1600 end-rings, 5150 Live Loading Assemblies, and a new split bronze bushing. The main sealing rings of 5300 GTP die-formed, inhibited graphite rings are self-lubricating, low friction, and high purity. Manufactured from pure graphite ribbon tape without any fillers, binders, or resins, each ring is engineered to an accurate specific density for compression resistance, elasticity, and retention of size and shape—all of which are necessary to provide the best possible sealing performance. The 1600 end rings add both sealing and anti-extrusion properties to the five ring set. The 5150 Live Loading Assemblies are used to maintain constant gland load while compensating for in-service consolidation of the packing. The split bronze bushing is used to reduce stuffing box depth while acting as a bearing to maintain lance tube concentricity to the stuffing box in blowers that require more than a conventional five-ring set of packing.



- Split bronze bushing acts as a bearing to maintain lance tube concentricity
- Provides longer service life

Technical Data

Chemical Resistance:

Not recommended for use with highly ionized reducing acid or hydrochloric acids at elevated temperatures

Applications:

For use in sootblower applications to 45 bar g (680 psig)

5700 Product Reorder

Kit	mm			Inch			Quantity		Clearance		Reorder Number
	ID	OD	Bolt Dia.	ID	OD	Bolt Dia.	Bushing	Live Load	Axial	Radial	
1	60,33	76,21	9,5	2.38	3.00	0.375	1	2	1.077"	1.000"	032001
2	60,33	76,21	9,5	2.38	3.00	0.500	1	2	1.195"	0.635"	032002
3	60,33	79,29	12,7	2.38	3.13	0.375	1	2	1.313"	0.800"	032003
4	69,88	88,92	9,5	2.38	3.13	0.500	1	2	1.195"	0.635"	032004
5	69,88	88,92	12,7	2.75	3.50	0.375	1	2	1.313"	0.635"	032005
6	60,33	76,21	12,7	2.75	3.50	0.500	1	2	1.206"	0.800"	032006
7	60,00	80,00	12,0	2.36	3.15	0.472	1	2	30 mm	16 mm	032007
8	70,00	90,00	12,0	2.76	3.54	0.472	2	4	30 mm	23 mm	032008
9	60,00	80,00	12,0	2.36	3.15	0.472	2	2	30 mm	16 mm	032009
10	70,00	90,00	10,0	2.76	3.54	0.393	2	4	30 mm	23 mm	032010

5700B Product Reorder

Kit	Inches			Quantity		Reorder Number
	ID	OD	Stud Size	Bushing	Live Load	
1	2.375	3	3/8"	1	2	034814
2	2.375	3	1/2"	1	2	034815
3	2.375	3.125	3/8"	1	2	034816
4	2.375	3.125	1/2"	1	2	034817



TOOLS

179

Gasket Cutter and Accessories

Chesterton Gasket Cutter utilizes a sturdy brass cutting head that slides easily over a variety of gasket materials. The unique design gasket cutter allows you to quickly adjust your cutting size from 6 mm ID to 940 mm OD (1/4" ID to 37" OD). Specially designed cutting blades are held securely, ensuring consistent and repetitive cuts in material up to 19 mm (3/4") thick. Includes 457 mm (18") cutting board with fiber pad.

Gasket Cutter Kit (Metric) Reorder No. 042651

Gasket Cutter Kit (Inch) Reorder No. 042650



174

Packing Knife

Chesterton 174 Packing Cutting Knife has a fine, bevelled blade to cut braided packings, and a serrated blade to cut molded items.

Blade length 125 mm (5")

Overall length case included 250 mm (10")

Reorder No. 002300



178

Ring Packing Cutter Kit

Chesterton 178 Ring Packing Cutter permits accurate cutting of rings from spiral or flat coil packings. The scale reads directly in terms of shaft sizes, in inches and, in millimeters. To operate, simply set one scale to correspond with cross-sectional size of packing, set other scale for shaft diameter, and cut ring. Handles packing sizes 3 mm (1/8") through 25 mm (1") and shaft sizes up to 100 mm (4").

Kit Reorder No. 003400

Knife for Ring Packing Cutter Reorder No. 003402



176

Tamping Tools

Chesterton 176 Tamping Tools are applicable for use on valves and pumps to tamp the packing into the stuffing box.



Product Reorder			
Packing Size	Pump Item Number	Packing Size	Reorder Number
1/8" to 6 mm	002505	6 mm to 5/16"	002306
1/4" to 5/16"	002507	3/8" to 12 mm	002307
3/8" to 12 mm	002508	1/2" to 3/4"	002308
1/2" to 3/4"			002309

242

Stiff Packing Extractors

Chesterton 242 Stiff Packing Tools are made of a special tool steel to withstand the roughest usage. They are warranted not to break when removing packing from any type of stuffing box. The 242 packing tools are only sold in complete sets of six.

Reorder No. 002402



253

Flexible Packing Extractors

Chesterton 253 Flexible Packing Extractors are designed for strong pull packing removal. Construction features include high strength aircraft cable, precision heat-treated extracting worm, and unbreakable rotary-swaged assembly. Worm tips have plastic protective coating. Large, smooth, easy-grip handle. Furnished in sets of four tools.



Product Reorder		
Number	Minimum OD	Reorder Number
Set		002400
0	requires 4.2 mm (0.165")	002499
1	requires 6.6 mm (0.260")	002501
2	requires 10.7 mm (0.420")	002502
3	requires 10.7 mm (0.420")	002503

Water Jet Packing Extractor

The Water Jet Packing Extractor system consists of an air operated, high pressure pumping system, high pressure hose, extraction gun, portable reservoir, and nozzle kit. This system has been designed for fast and efficient removal of valve stem packing, pump packing, and flange gaskets.

Reorder No. 104991



Sure-Cut Packing Cutter

The Sure-Cut Packing Cutter will save time, money, and braided packing while providing precision butt and skive cuts for the highest quality packing installations. The Sure-Cut Packing Cutter provides fast, accurate cuts every time and has been tested and will cut a number of different Chesterton packings* including 412-W, 1724, 1727, 1730, 1400, 1400R, and 1600.** Sure-Cut Maintenance Kit which includes a pocket sharpener and replacement blade is also available.

Reorder No. 001924

Maintenance Kit Reorder No. 001925

Kevlar® is a registered trademark of E.I. du Pont de Nemours and Company.



* Not recommended for Kevlar® products.
** Cuts up to 5/8" cross section for 45° skive cuts and up to 1" for butt cuts for all styles.

Equipment and Process	Chesterton Packing
Asphalt Plants	
Asphalt Pumps 600 F.P.M.	1760, 1400R/(477-1), 1830
Asphalt Pumps 1200 F.P.M.	1760, 1400R/(477-1), 1830
Bituminous Tank Agitators	1730SC, 1400R/(477-1)
Asphalt Loading Pumps	1760, 1400R/(477-1), 1830
Emulsified Asphalt Pumps	1760, 1400R/(477-1), 1830
Solvent Pumps	1760, 1400R/(477-1), 1830
Light Flux Pumps	1765
Auto Assembly	
Bonderite pumps	1765
Paint pumps	1727, 412-W, InnerLube
Battery Manufacture	
Acid pumps	1760, 1765
Hydraulic platen presses	600, 6000, 8000, 10,000
Bottling Companies	
Bottle washer	1730, 1727, 1760, 1765, 1830
Breweries	
Air compressor	1730, 1400R, 1727, 1760, 1830
Ammonia compressor	1400R/(477-1)
Ammonia valves	1400R, 477-1, 1724
Liquid ammonia pumps	1400R, 477-1, 1730, 412-W
Corn syrup pumps	1730, 412-W
Brine pumps	1730, 412-W
Beer pumps	1730, 412-W, 425, 1725A
Stock pumps	1760, 1730, 412-W, 1830
Rinse pumps	1760, 1730, 412-W, 1765, 1830
Slurry pumps	1760, 1730, 412-W, 1830
Caustic rinse pumps	1760, 1730, 1830
Storage tanks	185, 289
Feed water treatment tanks	185, 289
Cookers and kettles	184, 185, 1724, 425
Brick Manufacturing	
Oven door gaskets	345, 289, 160, 161, 162
Steam pumps - rods	1400R/(477-1), 1724, 1760
Tunnel kiln pushers	600, 8000, 10,000
Cement Plants	
Sludge pumps	1730, 1727
Chemical Plants	
Mild chemicals pH 5 to 9	1760, 1730, 1727, 1830
Strong acids pH 1 to 4	
Valves & reciprocating	1724, 1765
Centrifugals	1760, 1765, 1724, 324, 1830
Strong caustics pH 10 to 14	
Valves & reciprocating	324, 1724, 1765
Centrifugals	1765, 1760, 1724, 324, 1830
Solvent pumps	1765, 1727, 1730, 1760, 1830
Sheet Packings:	
Tank and door gaskets:	
Regular	185, 289
Solvents	184, 185
Cold oils	124, 140
Acids	459, 198, 199, 184, 185, ECS-T
Alkalies	459, 198, 199, 184, 185, ECS-T
Hot solvents	459, 198, 199, 184, 185, ECS-T
Steam	459, 199, 457, 455
Coal Mines	
Centrifugal pumps	1730, 1727, 1830
Plunger pumps	600, 8000, 10,000
Strip mine shovels, jacks	600, 8000, 10,000
Cold Storage	
Ammonia compressors	1400R/(477-1)
Ammonia valves	1400R/(477-1), 1724

Equipment and Process	Chesterton Packing
Corn Processing	
Acid pumps	1765, 1760, 1830
Alkaline pumps	1765, 1727, 1730, 1760, 1830
Stock pumps	1727, 1730, 1830
Cotton Ginning	
Presses, hydraulic pumps	800, 8000, 10,000
Cotton Seed Oil	
Oil pumps	1727, 1730, 1830
Hexane pumps	1760, 477-1, 1400R/(477-1)
Compress, rams	600, 6000, 8000, 10,000
Creosote Treating	
Pressure pumps:	
Centrifugal	
Reciprocating	1400R/(477-1), 1760
Liquid rods	1760, 1724
Steam rods	1760, 1724
Pressure tank door gaskets	1727, 1730, 1724
Dairies	
Food or milk	1725A, 425
Homogenizers, viscolizers	
Bottle and can washer pumps	1725A, 425
Distilleries (also see Breweries)	
Whiskey pumps	1725A, 425
Rinse pumps	1725A, 425
Slop, mash pumps:	
Centrifugal	1725A, 425
Reciprocating	1725A, 425
Evaporating drum driers	324, 1724, 1730SC
Elevator Repair and Manufacturing	
Hydraulic jack (ram)	600, 6000, 8000, 10,000
Farm Machinery (repairs, earthmoving)	
Hydraulic rams and rods	600, 6000, 8000, 10,000
Fertilizer Plants (also see and include recommendations for Fish Oil and Meal)	
Acid pumps	1765, 1760, 1830
Fish Oil and Meal	
Acid pumps	1765, 1760, 1830
Caustic wash pumps	1765, 1727, 1730, 1830
Fish pumps:	
Centrifugal	1727, 1730
Reciprocating	1727, 1730
Cooker, retort gaskets	289, 184, 185
Food Processing (also see Meat Packing)	
Blood cookers	1765, 1725A, 425
Food pumps:	
Centrifugals	1725A, 425
Reciprocating	1725A, 425
Cooker or retort gaskets	289, 184, 185
Ammonia compressors	1400R/(477-1)
Ammonia valves	324, 1724, 1400R/(477-1)
Mixers	1725A, 425
Gaskets	184, 185
Forging Plants	
Steam hammer rods:	
End rings	1724, 477-1
Balance	600
Furniture Manufacturing	
Backbenders	600, 8000
Steam chest gaskets	289, 1600

NOTE:
 1400R/(477-1) – Combination sets of 1400R with 477-1 as anti-extrusion rings.
 324/DigesterPak/477-1T – See DigesterPak Application Guide (Form No. 088146).

Equipment and Process	Chesterton Packing
Gas Manufacturing	
Ammonia solutions	1400R/(477-1), 1727, 1730
Ammonia valves	1400R/(477-1), 324, 1724
Crude Oil	1400R/(477-1), 1727, 1730
Exhauster shafts	1400R/(477-1)
Fuels and gas oil	1400R/(477-1), 1727, 1730
Gas tar, tar water	1400R/(477-1), 1727, 1730
Generator ash and clinker doors	289
Hot valves:	
Generator to carburetor	5300/One-Cl, GTP, 1600, 1400R/(477-1)
Naphthalene	1400R/(477-1)
Oil splash lubricated engines	1400R/(477-1), 1727, 1730
Purifier box cover and door seals	289
Seal, box and scrubber	1727, 1730
Greenhouses (also see Power Generating Plants)	
Humidifier centrifugals	1727, 1730, 1830
Gold Mines	
Reciprocating sludge pumps	1765, 1760
Reciprocating slime pumps	1765, 1760
Centrifugals	1765, 1760, 1730, 1727, 1830
Acid pumps	1765, 1760, 1830
Hospitals (also see and include Power Generating Plants recommendations)	
Ammonia compressor	1400R/(477-1)
Expansion joints	324, 1724
Fire pumps – Centrifugals	1400R/(477-1), 1727, 1730, 1760, 1830
Feed and vacuum pumps	1400R/(477-1), 1760, 370, 1830
Sterilizers, autoclaves (gaskets)	185, 289
Junk Yards	
Hydraulic reciprocating oil pumps	600, 8000
Body baling press	600, 6000, 8000, 10,000
Laundry – Dry Cleaning (also see Power Generating Plants)	
Filter cloth gasket	140
Solvent pump	1765, 1727, 1730, 1760, 1830
Soap pump	1765, 1727, 1730, 1760, 1830
Air compressor	1730, 1727, 1760, 1830
Flat work ironer, mangles, presses	1730SC
Loading Platforms and Equipment	
Rams	600, 6000, 8000, 10,000
Lumber Operations	
Shotguns, feed engines, riggers, winches donkey engines, log turners, loaders	
Use end rings	
Balance of set	1730SC
Also recommended	600, 8000
Meat Packing	
Crackling press	600, 6000, 8000, 10,000
Hydraulic pumps	600, 8000
Blood cookers	1725A, 425
Tree washer pumps	1727, 1730, FDA 1725A, 425
Cookers, dryers, blenders	1727, 1730, FDA 1725A, 425
Cookers, dryers-gaskets	289
Stock liquor pumps	1765, 1760
Acid pumps	1765, 1760
Caustic pumps	1765, 1760
Ammonia compressor	1400R/(477-1)
Ammonia valves	324, 1724
Metal Casting	
Quench – oil pumps	1727, 1730
Hydraulic pumps	1727, 1730, 600, 1760
Accumulators	600, 6000, 8000, 10,000
Hydraulic rams	600, 6000, 8000, 10,000

Equipment and Process	Chesterton Packing
Oil Refineries	
For critical installations where mechanical seals are advisable because of explosive conditions, or where economy requires minimum loss of fluids, selection should be made from our range of <i>Chesterton Mechanical Seals</i> . In this category of fluids are solvent vapors, solvent charges, solvent oils, propane, butane and the like. Other recommendations for soft packings are as follows:	
Mild chemicals – pH 5 to 9	1727, 1730, 1760, 1830
Strong acids pH 1 to 4	
Valves and reciprocating	324, 1724, 1760
Centrifugals	1765, 1760, 1724, 1830
Strong caustics pH 10 to 14	
Valves and reciprocating	324, 1765, 1724, 1760
Centrifugals	324, 1724, 1760, 1830
Oil Refineries	
Gasoline, Lubricating Oils, Light Fuel Oils: up to 230°C (450°F)	1400R/(477-1), 1724, 1727, 1730, 1760, 1830
over 230°C (450°F)	1400R/(477-1), 370
Hot crude charge pumps and hot oil pumps: over 200°C (400°F) when flushed	1400R/(477-1), 370
Note: deep boxes over 6 rings require special bottom bushings	
Control valves, chemical valves: to 260°C (500°F)	5800, 5800E, 5800T, 1622, 1400R/(477-1) GTP/ONE, 324, 1724
over 260°C (500°F)	5800, 5800E, 1622, 1400R/(477-1), GTP/ONE
Block valves, chemical	1622
Steam valves:	
High temperature	1400R/(477-1), GTP, 1601
Condensate centrifugal pumps	1400R/(477-1), 370, 1830
Cooling tower acid pumps	1727, 1730, 1760, 1830
MEK Unit Filters	1400R/(477-1), 324, 1724, 5300
Asphalt:	
Reciprocating pump rods, steam end	1760, 1730SC, 1724
Air compressor	1730, 1727, 1760, 1830
Refrigeration	1400R/(477-1), 1760, 370
Power Plant (see Power Generating Plants)	
Sheet Packings	
Cold oils	140, 455, 457
Hot solvents	184, 185, ECS-T
Acids	184, 185, ECS-T
Caustics	459, 199, 184, 185, ECS-T
Steam	459, 199, 457, 455
General purpose	455, 457
Gaskets:	
Regular	140, 455, 457
Solvents, chemicals	184, 185, ECS-T
Paint Manufacturing	
Paint pumps	1727, 412-W
Solvent pumps	1760, 1730, 1727, 1830

NOTE:
 1400R/(477-1) – Combination sets of 1400R with 477-1 as anti-extrusion rings.
 324/DigesterPak/477-1T – See DigesterPak Application Guide (Form No. 088146).

Equipment and Process	Chesterton Packing	Equipment and Process	Chesterton Packing
Paper and Pulp Mills		Phosphate Mines	
Control valves to 260°C (500°F)	5800, 5800T, 1724,	Phosphate centrifugal pumps	1730, 1727, CMS 2000
Mild chemicals – pH 5 to 9	412-W, InnerLube, 1730, 1727, 1830	Acid pumps	1724, 1765, 1760
Strong acids – pH 1 to 4: Valves and reciprocating Centrifugals (also seals)	1760, 1765, 1830 1400R/(477-1), 1724, 1760 1730, 1760, 1727, 1400R/(477-1T), 1830	Piano Manufacturing	
Strong caustics – pH 10 to 13: Valves and reciprocating Centrifugals	1400R/(477-1), 1724, 1760 1730, 1760, 1727, 1400R/(477-1T), 1830	Platen press rams	1760, 477-1, 477-1T
Sheet Gaskets: Steam and general Caustics Acids Water	455, 459, 457 ECS-T, 459, 185 ECS-T, 459, 185 100, 175	Hydraulic pump and accumulator	1760, 477-1, 477-1T
Stock pumps, Jordans, Claffins	370, 1730, 1760, 1727, GraphMax 1400R/(477-1T), 1830-SSP	Plastic Moulding	
Hydropulpers, hydrofiners	370, 1730SC, 1760, 1727, GraphMax, 1400R/(477-1T), 1830-SSP	Rams of press	1760, 477-1, 477-1T
Refiners, stock chests	1730, 1760, 370, GraphMax, 1400R/(477-1T), 1830-SSP	Hydraulic pump and accumulator	1760, 477-1, 477-1T, 1830
White water pumps	1730, 1760, 1727, GraphMax, 1400R/(477-1T), 1830-SSP	Plywood Manufacturing	
White liquor pumps	1760, 1727, 1400R/(477-1T), 1765, GraphMax	Curing press	1760, 477-1, 477-1T
Black liquor pumps (also seals)	1400R/(477-1T), 1760, 324/ DigesterPak/477-1T, GraphMax	Lathes	1760, 477-1, 477-1T
Green liquor pumps (also seals)	1760, 1400R/(477-1T), 370, GraphMax	Hydraulic pump and accumulator	1760, 477-1, 477-1T, 1830
Bleach liquor pumps	1765	Potteries	
Chlorine pumps	1765	Glaze pumps, pottery slip	1765, 1724, 1730, 1727
Evaporators	1760, 1400R/(477-1T), 1765, GraphMax	Soup pumps (plunger)	1760, 477-1, 477-1T
Sulphate and soda, digester	1760, 1765, 324/ DigesterPak/477-1T	Power Generating Plants (For All Industries)	
Sulphate digester top gland	1760, 1765, 324/ DigesterPak/477-1T	Steam valves:	
Sulphate acid, digester	1760, 1765	High temperatures under 260°C (500°F)	GTP/ONE, 1600, 1400R, 477-1 GTP/ONE, 324, 1724, 1601, 1400R, 477-1
Lime slurry	1400R, 1760, 324/ DigesterPak/477-1T, GraphMax	Isolating valves	GTP/ONE, 1601, 1400R, 477-1
Sodium chlorate	1765	Soot blower	5700B
Hydraulic pumps, accumulator	1724, 1760	Stokers	1600, 1400R/(477-1)
Cold water rods	1724, 1760	Ash sluice pumps:	
Cold water shafts	1730, 1727, 1760, 412-W, InnerLube, 1830-SSP	Bottom ring	1740, 477-1
Pocket grinder	412-W, InnerLube, 1730	Balance	1730, 1727, 1760, 1400R
Raw acid pumps	1765	Condensate pumps	1760, 1400R/(477-1), 370, 1830
Mixers, bleach dept	1765	Circulating and cooling pumps:	1760, 477-1, 1730, 1727, InnerLube, 412-W, 1830
High density stock pump	1730, 1760, 370, GraphMax, 1400R/(477-1T), 1830-SSP	Boiler feed pumps	370, TWO, 1400R/(477-1), 1830
Drying cylinder box	InnerLube, 1730	Fuel oil service	1400R/(477-1), 1760, 1730, 1830
Vacuum pumps	InnerLube, 1730, 370, 1830-SSP	Transfer pumps	1400R/(477-1), 1760, 1730, 1830
Pharmaceutical		Milton-Roy or Proportioners	
Control valves, to 260°C (500°F)	GTP, 1724, 5800	Chemical Injectors:	
Steam valves	GTP, 1724, 1600, 1400R	Acid	324, 1724, 1760
Pumps:		Alkalines	324, 1724, 1760
Neutral liquids	1727, 1725A, 1765, 1730, 425, 1830	Sheet gasket services	455, 457, 459, ECS-T, 199
Liquids subject to discoloration	1727, 1725A, 1765, 1730, 425	Heat exchanger gaskets	252, 459, 199
Acids	1765, 1724, 1760	Rolling Mills	
Alkalies	1760, 1765	Cooling systems: Centrifugal pumps –	
Solvents	1724, 1730, 1727, 1760, 1830	Coolant, booster, balance, filter:	
Kettle gaskets:		Oil	324, 1724, 1760, 1830
Glass joints	184, 185	Water	1730, 1727, InnerLube, 412-W, CMS 2000, 1830
PTFE tape for chemicals	185	Geared pumps	1760, 1400R/(477-1), 1830
		Valves:	
		Oil	GTP/ONE, 1600, 477-1
		Water	GTP/ONE, 1600, 477-1
		Heat exchanger:	
		Head gaskets	252, 459, 199
		Oil gaskets	252, 459, 199
		Remelt Dept. – casting pit rams	600, 6000, 10,000
		Pumps – furnace, casting pit, balester, cut-off saw	1760, 477-1, 1730
		Sump pump, boring machining pump	1760, 1730
		Valves	GTP/ONE, 1600, 1400R, 477-1
		Pump House:	
		Fire pump	1730, 477-1, 1760, 1400R, 1727, 1830, GraphMax
		Turbine pumps, condensate, water	1730, 477-1, 1760, 1400R, 1727, 1830

NOTE:
1400R/(477-1) – Combination sets of 1400R with 477-1 as anti-extrusion rings.
324/DigesterPak/477-1T – See DigesterPak Application Guide (Form No. 088146).

Equipment and Process	Chesterton Packing
Rolling Mills	
Propane Plant:	
Valves	GTP/ONE, 324, 1724, 1400R, 477-1
Compressor	1760, 1724
Rotary displacement meter, control valves	GTP/ONE, 324, 1724, 5800
Sewage Disposal:	
Sewage	1730, 1760, InnerLube, CMS 2000, 1727, 1830
Circulating	1730, 1760, InnerLube, CMS 2000, 1727, 1830
Extrusion:	
Leveller rams	600, 6000, 8,000, 10,000
Hydropress	1760, 1730, 6000, 10,000
Tube Dept.:	
Embossers, bridal assembly jacks	6000, 10,000
Draw bench, tube pointer pumps	1760
Slitter pumps	1760, 1730
Hot Mill, Tandem Mill jacks	6000, 8000
Rubber Manufacturing	
Rams of platen presses	600, 6000, 8000, 10,000
Press pullbacks	600, 6000, 8000, 10,000
Hydraulic pumps and accumulators	600, 8000, 10,000
Solvent pumps	477-1, 1400R, 1760, 1830
Solvent cement mixers	1730, 1740, 1760
Mills, crackers:	
Steam end	1601
Water end	1760, 1727, 1730, InnerLube
Calenders:	
Steam end	1724, 477-1
Water end	1760, 1727, 1730, InnerLube, 1830
Air compressors	1730, 1727, 1760, 1400R, 1830
Steam valves:	
High temperatures under 260°C (500°F)	GTP/ONE, 1601, 477-1, 1400R GTP/ONE, 324, 1601, 1724, 477-1, 1400R
Regulator valves	5800, GTP/ONE, 324, 1724, 1601
De-vulcanizers	1600, 1601
Pipe flange gaskets	252, 459, 199, ECS-T
Sewage Disposal	
Centrifugal pumps	1730, 1760, 1727, CMS 2000, InnerLube, 1830-SSP
Sludge pump (plunger type)	600, 1760, 1727, 1730
Mudhog pump	1727, 1730, InnerLube
Sump pumps:	
Acid	1765, 1724, 1760, 1830
Alkalines	1724, 1765, 1760, 1830
Water valves	477-1, 1400R, 1724, GraphMax

Equipment and Process	Chesterton Packing
Ships and Shipyards	
Condenser pumps	1760, 1730, 1727, InnerLube, 412-W, 1830
Condensate pumps	370, 1760, 1400R/(477-1), 1830
Chemical transfer pumps	1724, 1765, 324, 1760, 1830
Transfer pumps (neutral products)	1760, 477-1, 1730, 1727, InnerLube, 1400R, 1830, GraphMax
Discharge pumps	1760, 477-1, 1730, 1400R, 1830, GraphMax
Pure water pumps	1730, 1765, 1724, 1760, 1830
Chemical injection pump	1765, 1724, 1760
Boiler feed pumps	370, TWO, 1400R/(477-1), 1830
Stern tube	329, 412-W
Rudder post	329, 412-W
Salt water pumps	1760, 1730, 1727, InnerLube, 412-W, 1830
Hydraulic pumps (cent.)	1760, 477-1, 1730, 1830
Ballast and bilge pumps	1760, 1730, 1727, InnerLube, 412-W, 1830
Fire pumps	1730, 1760, 1400R/(477-1), 1727, 1830
Fuel and lube oil pumps	1730, 1760, 1400R/(477-1), 1727, 1830
Steam:	
High temperature valves to 650°C (1200°F)	GTP/ONE, 1601, 1400R
Medium temperature valves to 260°C (500°F)	GTP/ONE, 1601, 1400R, 477-1
Low temperature valves	GTP/ONE, 324, 1724, 477-1, 1601, 1400R
Reciprocating pumps	1760, 1724
Gaskets:	
Fuel, chemical hatches	184, 185, ECS-T, 459, 199
Steam	459, 199, 252, 455, 457
Water	100, 450
Diesel oil	140, 455, 457
Soap Making (Generally follow the same recommendations as for Chemical Plants)	
Other suggestions: Toothpaste, shampoos, deodorants, hair conditioners (slow speed pumps)	324, 1724, 1725A, 425
Agitator shafts	
Highly acid	1765, 1724
Highly caustic	1765, 1760, 1724, 1830
Neutral	1730, 1760, InnerLube, 1727, 1830
Solder Manufacturing	
Rams extruding presses	600, 6000, 8000, 10,000
Soy Bean Oil	
Rams of compressors	1760, 1740, 1724
Hydraulic pumps	600, 6000, 8000, 10,000
Hexane pumps	1400R/(477-1), 1760, 1830
Oil pumps	1400R/(477-1), 1760, 1730, 1727, 1830
Rotary driers	1730, 1727, 1830
Chandler drilling machine	1730, 1727
Stone, Crushed	
Air compressor	1730, 1760, 1830
Asphalt pump	1400R/(477-1), 1760, 1830
Centrifugal sludge pumps	1730, 1727, 1760, CMS 2000, 1830
Clear water pump	412-W, InnerLube, 1730, 1830
Fuel oil pump	1400/(477-1), 1730, 1760, 1830

NOTE:
1400R/(477-1) – Combination sets of 1400R with 477-1 as anti-extrusion rings.
324/DigesterPak/477-1T – See DigesterPak Application Guide (Form No. 088146).

Equipment and Process	Chesterton Packing
Raw Sugar Mill (Cane) (also see and include Power Generating Plant)	
Cleaning Plant:	
Mud pumps	1730, 1727, 1400R/(477-1)
Water pumps	1730, 1760, 1727, 1400R/(477-1), 1830
Lime slurry pumps	1760, 1400R/(477-1)
Crushing Plant:	
Raw juice pumps	1730, 1400R/(477-1), 1760, 1727, 1830
Water pumps	1730, 1400R/(477-1), 1760, 1727, 412-W, 1830
Condensate pumps	1730, 1400R/(477-1), 1760, 1727, 1830
Accumulator	477-1, 1760
Boiling House:	
Clarified juice pumps	1400R, 1725A, 1730, 425, 412-W, 1760
Sweet water pumps	1400R, 1725A, 425, 1760
Molasses pumps	1400R, 1725A, 425, 1760
Massecuite pumps	1730, 1727, 1760
Salt water	1760, 1727, 1730, InnerLube, 412-W, 1830
Caustic soda	1760, 1400R/(477-1), 1830
Limed juice	425, 1725A, 1760, 1730
Hot syrup	425
Remelt sugar	1725A, 425
White Sugar Refining	
Melter House:	
Mingler glands	1725A, 425, 1400R
Centrifugal mixer glands	1725A, 425, 1400R
Affination syrup	1725A, 425, 1400R
Melter liquor pumps	1725A, 425, 1400R
Filter House:	
Clarifier liquor pumps (treated)	1724, 1765, 1760, 1400R
Carbonation liquor pumps	1760, 1727, 1730, 1400R, 1765
Filter press, rotary and sluicing pumps	1760, 1727, 1730, 1400R
Press cake slurry pump	1724, 1760, 1765
Lime slurry pump	1760, 1400R/(477-1)
Activated carbon slurry pump	1730, 1727, 1760, 477-1, 1400R
Filter medium slurry (diatomaceous earth)	1760, 370, 1730, 1400R
Acid pump – dilute	1760, 1765, 1730
Acid pump – concentrated	1724, 1765, 1760
Pan House:	
Vacuum pan circulator glands	1730, 1727, 1760
Evaporator pumps	1730, 1727, 1760
Crystallizer glands	1730, 1727, 1765, 1760
Centrifugal mixer glands	1730, 1727, 1760
Liquor, syrup, and remelt pumps	1725A, 425, 1760, 1730
Magma pumps	1760, 1724
Scale treatment pumps (caustic)	1760, 1765, 1724, 1400R
Scale treatment pumps (acid)	1765, 1724, 1730, 1760
Condensate water pumps	1730, 1727, 1400R/(477-1), 370
Commercial liquor pumps	1760, 1725A, 425
CO ₂ pumps	370, 1400R/(477-1), 1760
Salt water pumps	1760, 1730, 1727, InnerLube, 412-W, 1830

All statements in this catalog pertaining to pressure, chemical compatibility, temperature, and service ratings are based on general service experience. Because of the wide variety of applications of our products, the broad range of products available, and the wide range of equipment conditions encountered, together with the unpredictable human factors involved in the installation of these products by the ultimate user, you should not follow recommendations shown without specific prior service experience or consultation with an authorized Chesterton representative.

Specific data on materials, construction methods, installation, and troubleshooting procedures are subject to change without notice.

Equipment and Process	Chesterton Packing
Textile Mills (also see and include Power Generating Plant)	
Steam valves	GTP/ONE, 1600, 1400R, 477-1
Control valves	GTP/ONE, 5800, 1600, 1400R, 477-1, 1724
Air compressor	1730, 1760, 1830
Dry cans, slasher	1730, 1727, 1760
Pumps:	
Humidifier	1727, 1730, 1760, 1400R/(477-1), 1830
Circulating	1727, 1730, 1760, 1400R/(477-1), 1830
Screen	1727, 1730, 1760, 1400R/(477-1), 1830
Filtrate	1727, 1730, 1760, 1400R/(477-1), 1830
Size – starch	1400R/(477-1), 1760, 1830
Size – acrylic	1724, 1727, 1730, 1765
Dye	1724, 1765, 1760
Bleach	1765, 1724, 1760
Textile Finishing and Dyeing	
Service and Metering Pumps:	
Sulphuric acid	1724, 1765
Hydrochloric acid	1724, 1765, 1760
Acetic acid	1724, 1765, 1760, 1400R
Hydrogen Peroxide (90%)	1724, 1765
Sodium Hydroxide (caustic soda)	1760, 1400R/(477-1), 1765, 1830
Cloth heat treating (formaldehyde – textile resins)	
Bleaching – sodium hypochlorite	1724, 1765
Sizing – sodium sillcate	1730, 1727, 1760, 1830
Steam valves on continuous service	GTP/ONE, 1600, 1400R, 477-1
Drying cylinders – end of journals	459, 455, 457
Diaphragm motor valves	122-NN
Bailing presses	600, 6000, 8000, 10,000
Thermo Plastics (see Plastic Moulding)	
Utilities (see Power Generating)	
Veneer (see Plywood)	
Water Works	
Water Works:	
Plunger pumps	1730, 1760, 600
Centrifugal pumps	1730, 1760, 1400R/(477-1), 1830 InnerLube, 412-W
Water treating pumps	
Chlorine	1724, 1765
Caustic	1724, 1765, 1760
Acids	1724, 1765
Water valves	1724, 1400R/(477-1), 1600
Whiskey Manufacturing (see Distilleries)	
Wines (see Distilleries)	
Wire Manufacturing	
Continuous vulcanizers	1724, 324, 1600, 477-1
Wood Production (see Lumber Operations)	

Performance is closely associated with the process operating conditions and equipment conditions. Technical data reflects results of laboratory tests and is intended to indicate general characteristics only. A.W. CHESTERTON COMPANY DISCLAIMS ALL WARRANTIES EXPRESSED, OR IMPLIED, INCLUDING WARRANTIES OF MERCHANTABILITY AND FITNESS FOR A PARTICULAR PURPOSE OR USE. LIABILITY, IF ANY, IS LIMITED TO PRODUCT REPLACEMENT ONLY.

NOTE:
1400R/(477-1) – Combination sets of 1400R with 477-1 as anti-extrusion rings.
324/DigesterPak/477-1T – See DigesterPak Application Guide (Form No. 088146).



GLOBAL SOLUTIONS, LOCAL SERVICE

Since its founding in 1884, the A.W. Chesterton Company has successfully met the critical needs of its diverse customer base. Today, as always, customers count on Chesterton solutions to increase equipment reliability, optimize energy consumption, and provide local technical support and service wherever they are in the world.

Chesterton's global capabilities include:

- Servicing plants in over 100 countries
- Global manufacturing operations
- More than 500 Service Centers and Sales Offices worldwide
- Over 1200 trained local Service Specialists and Technicians

Visit our website at
www.chesterton.com

Chesterton ISO certificates available on www.chesterton.com/corporate/iso

Masonellan® is a registered trademark of Dresser, Inc.
Fisher® is a registered trademark of Emerson Electric Co.
Inconel® is a registered trademark of Special Metals Corporation.
Kevlar® is a registered trademark of E.I. du Pont de Nemours and Company.
SprialTrac® is a registered trademark of Enviroseal Engineering Products Ltd.
Valtek® is a trademark of Flowserve Corp.

Technical data reflects results of laboratory tests and is intended to indicate general characteristics only.

A.W. CHESTERTON COMPANY DISCLAIMS ALL WARRANTIES EXPRESSED, OR IMPLIED, INCLUDING WARRANTIES OF MERCHANTABILITY AND FITNESS FOR A PARTICULAR PURPOSE OR USE. LIABILITY, IF ANY, IS LIMITED TO PRODUCT REPLACEMENT ONLY. ANY IMAGES CONTAINED HEREIN ARE FOR GENERAL ILLUSTRATIVE OR AESTHETIC PURPOSES ONLY AND ARE NOT INTENDED TO CONVEY ANY INSTRUCTIONAL, SAFETY, HANDLING OR USAGE INFORMATION OR ADVICE RESPECTING ANY PRODUCT OR EQUIPMENT. PLEASE REFER TO RELEVANT MATERIAL SAFETY DATA SHEETS, PRODUCT DATA SHEETS, AND/OR PRODUCT LABELS FOR SAFE USE, STORAGE, HANDLING, AND DISPOSAL OF PRODUCTS, OR CONSULT WITH YOUR LOCAL CHESTERTON SALES REPRESENTATIVE.



DISTRIBUTED BY:

860 Salem Street
Groveland, MA 01834 USA
Telephone: 781-438-7000
Fax: 978-469-6528
www.chesterton.com

© A.W. Chesterton Company, 2012. All rights reserved.
® Registered trademark owned and licensed by A.W. Chesterton Company
in USA and other countries, unless otherwise noted.

FORM NO. 073972

PRINTED IN USA 08/12