

2AUW, 3AUW

GASOLINE ENGINE SELF-PRIMING CENTRIFUGAL PORTABLE CONTRACTOR PUMPS

Commercial Water

FEATURES

Reliable Subaru Robin engines:

- Overhead cam design
- Low oil shutdown
- Automatic decompression system

Lightweight, portable and compact design.

Die cast aluminum casing, engine housing and volute.

Durable cast iron impeller.

Trouble-free mechanical seal, carbon/ceramic/BUNA-N.

Rugged, convenient carry handle/base.

Multi-position discharge connection.

Injection molded suction strainers.

Fittings to accommodate NPT connections.

Available in 2 sizes:

- 2" connections, 4.5 HP
- 3" connections, 6.0 HP

APPLICATIONS

Home, farm and cottage water systems and booster service.

PUMP SPECIFICATIONS

2AUW (2" Connections):

- Length: 20.50"
- Width: 15.00"
- Height: 15.75"
- Weight: 45 lbs.
- Solids: 1/2" Dia.

3AUW (3" Connections):

- Length: 20.75"
- Width: 15.50"
- Height: 17.25"
- Weight: 52 lbs.
- Solids: 1/2" Dia.

ENGINE SPECIFICATIONS

2AUW (2" Connections):

- Horsepower: 4.5 HP
- Displacement: 126 cc
- Fuel capacity: .7 gal.
- Oil capacity: 20 oz.
- Air cleaner: Paper
- Ignition: Electronic
- Run time: 2.7 hours

3AUW (3" Connections):

- Horsepower: 6.0 HP
- Displacement: 169 cc
- Fuel capacity: .95 gal.
- Oil capacity: 20 oz.
- Air cleaner: Paper
- Ignition: Electronic
- Run time: 2.5 hours

2AUW PERFORMANCE

Flow (GPM)	0	25	50	75	100	125	145
TDH (Ft.)	105	96	80	60	40	20	0

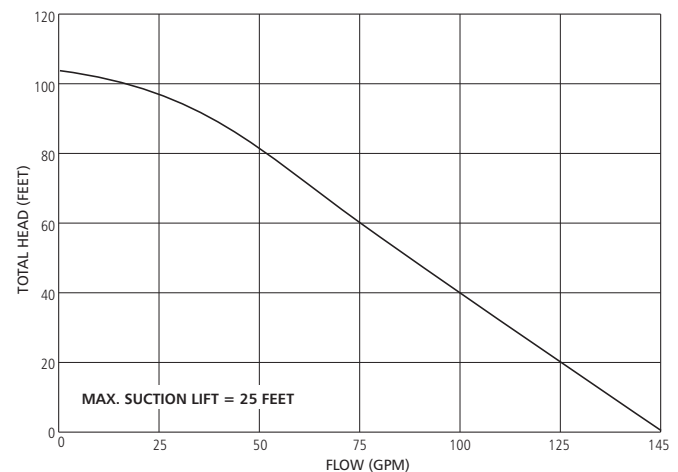

3AUW PERFORMANCE

Flow (GPM)	0	40	80	120	160	170
TDH (Ft.)	100	78	57	35	14	0

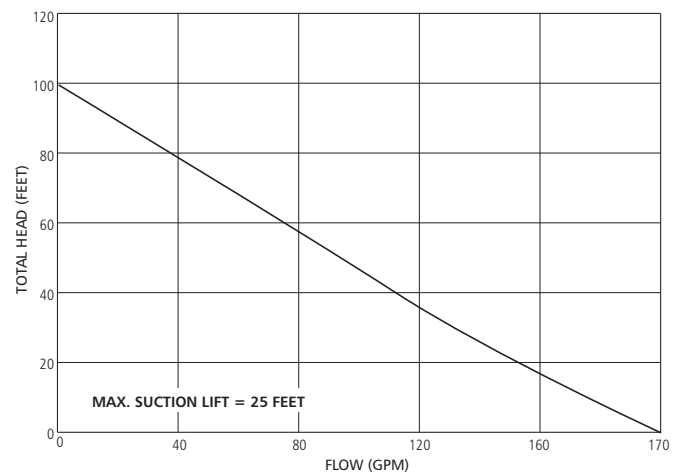

DIMENSIONS AND WEIGHTS

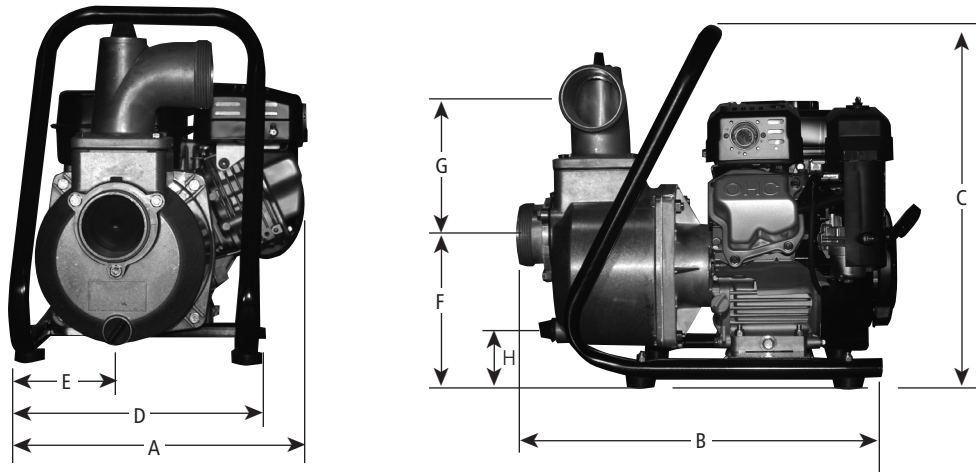

Model	Dimension (in inches)								Weight (lbs.)
	A	B	C	D	E	F	G	H	
2AU	15	18 ³ / ₄	15 ³ / ₈	14 ³ / ₈	5	7 ¹ / ₄	5 ¹ / ₄	2 ¹ / ₂	59
3AU	15	20 ³ / ₄	18 ¹ / ₂	12 ³ / ₄	6	7 ³ / ₄	7 ¹ / ₄	2 ¹ / ₂	63

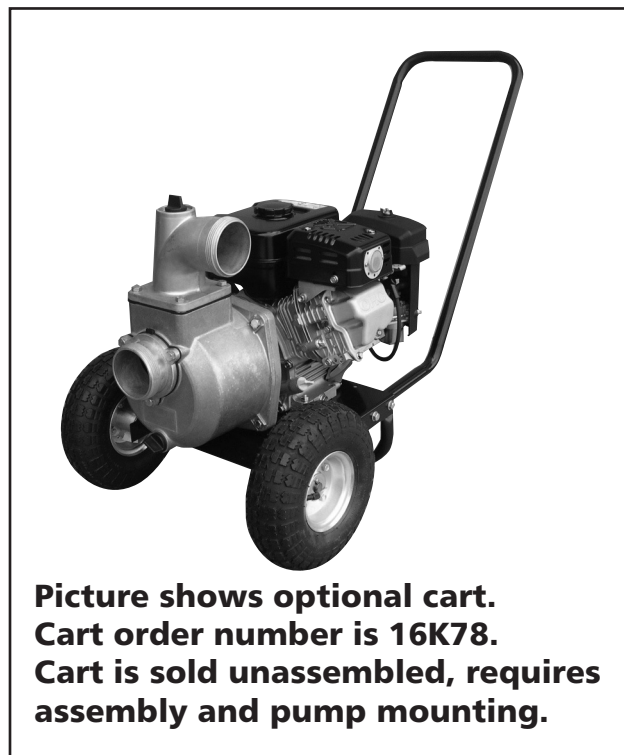

**Picture shows optional cart.
Cart order number is 16K78.
Cart is sold unassembled, requires
assembly and pump mounting.**

COMPONENTS LIST

Item No.	Part Description	Item No.	Part Description
1	Engine – 4½ HP	9	Suction strainer
	Engine – 6 HP	10	Pump housing
2	Locknut – ¾" – 16	11	Bolt – ¾" – 16" x 1½"
3	Engine adapter	12	O-ring, drain/filler plug
4	Aluminum washer – 5/16"	13	Drain/fill plug
5	Bolt – 5/16" – 24" x ¾"	14	Flapper valve
6	Seal assembly	15	Suction flange BSP*
	Shaft sleeve		Suction flange NPT
	O-ring housing	16	Bolt – 5/16" – 18" x 7/8"
	O-ring volute		Discharge elbow BSP*
7	Impeller	17	Discharge elbow NPT
	Volute		Discharge gasket
	Imp. shim: 010, 020, 030	18	Discharge gasket
8*	Hose mounting gasket	19	Bolt – 5/16" – 18" x 1½"
	Hose mounting nipple	20	Lock nut – 5/16" – 18
	Hose mounting nut	21	Cradle assembly
	Suction strainer		

*Supplied with 2AU, built before September 2005.

BSP fittings no longer available.

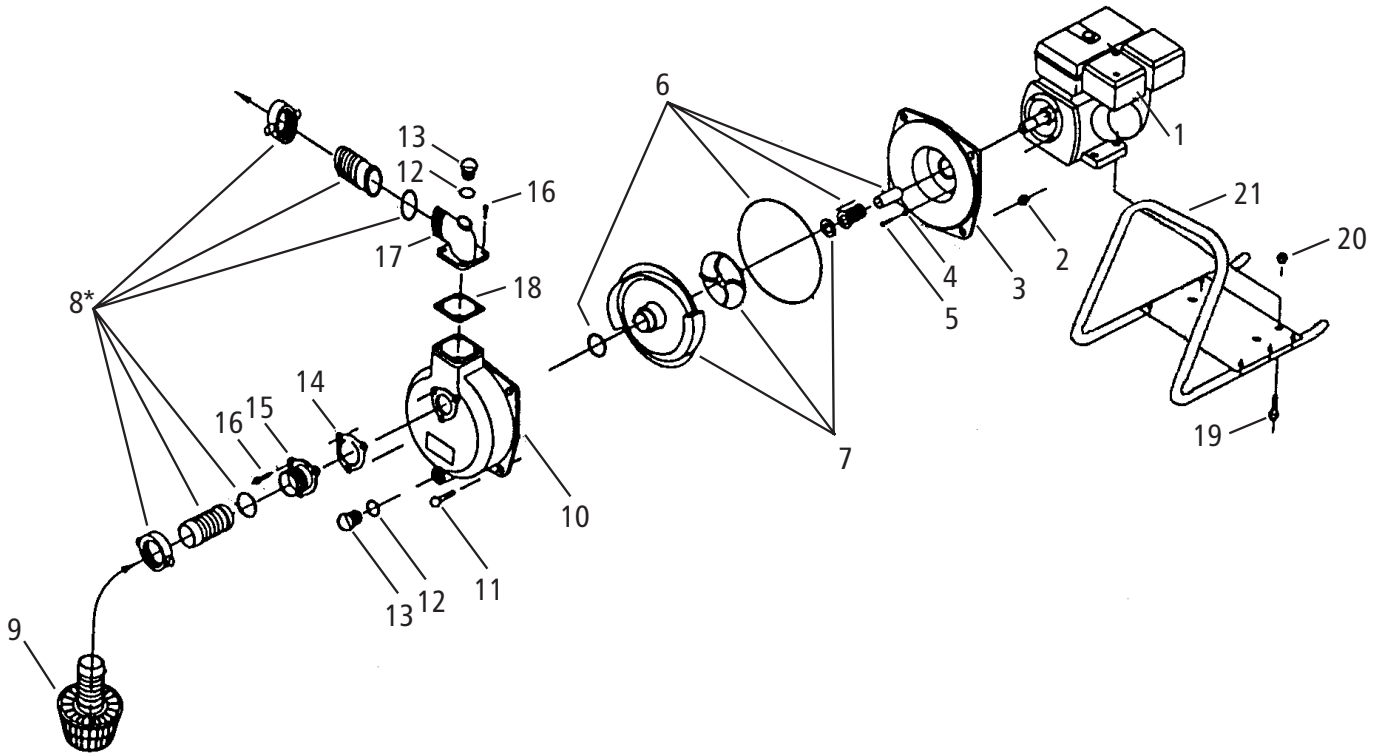

xylem
Let's Solve Water

Xylem, Inc.
2881 East Bayard Street Ext., Suite A
Seneca Falls, NY 13148
Phone: (800) 453-6777
Fax: (888) 322-5877
www.xylem.com/brands/gouldswatertechnology

Goulds is a registered trademark of Goulds Pumps, Inc. and is used under license.
© 2012 Xylem Inc. BAU March 2012