

G&L Pumps

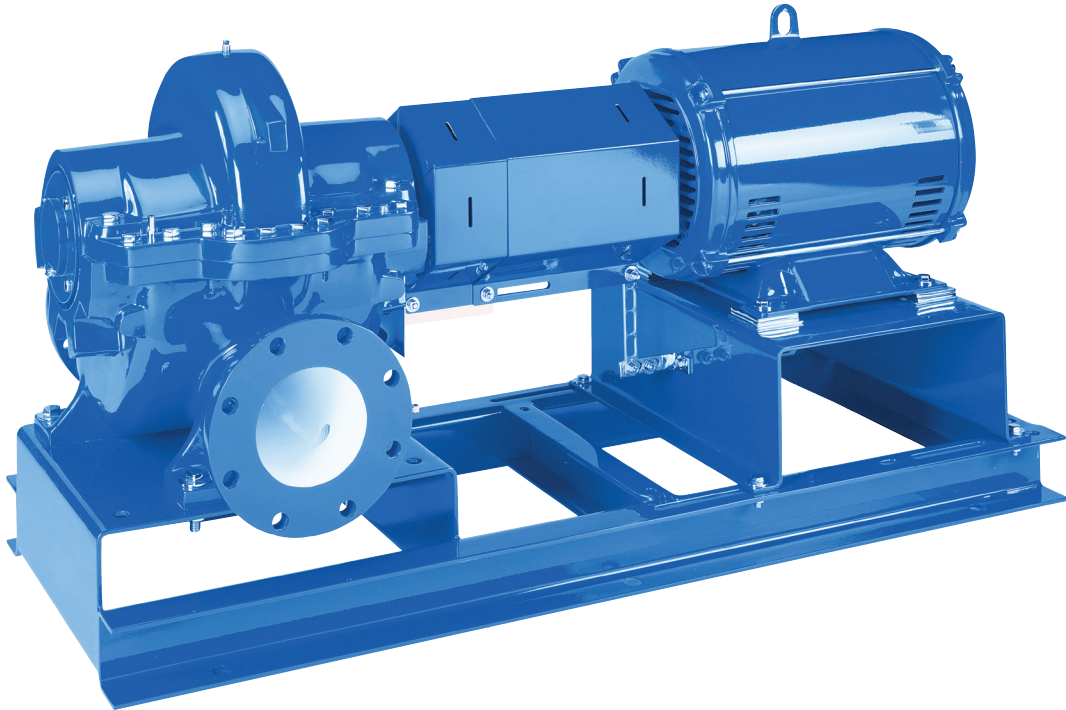

G&L Pumps

Series A-C 8300 - Split Case Pumps

GL-520

xylem
Let's Solve Water

G&L Pumps

Series A-C 8300

Table of Contents

Useful Pump Formulas.....	.2
Performance Curves.....	3-4
Materials of Construction (Standard).....	.4
L/D Ratio Comparison.....	.5
Dimensions.....	6-7
Engineering Specifications.....	.8

Useful Pump Formulas

Pressure (PSI)	=	$\frac{\text{Head (Feet)} \times \text{Specific Gravity}}{2.31}$
Head (Feet)	=	$\frac{\text{Pressure (PSI)} \times 2.31}{\text{Specific Gravity}}$
Vacuum (Inches of Mercury)	=	Dynamic Suction Lift (Feet) x .888 x Specific Gravity
Horsepower (Brake)	=	$\frac{\text{GPM} \times \text{Head (Feet)} \times \text{Specific Gravity}}{3960 \times \text{Pump Efficiency}}$
Efficiency (Pump)	=	$\frac{\text{Horsepower (Water)}}{\text{Horsepower (Brake)}} \times 100\%$
NPSH (Available)	=	Positive Factors - Negative Factors

Affinity Laws: Effect of change of speed or impeller diameter on centrifugal pumps.

	GPM Capacity	Ft. Head	BHP
Impeller Diameter Change	$Q_2 = \frac{D_2}{D_1} Q_1$	$H_2 = \left(\frac{D_2}{D_1}\right)^2 H_1$	$P_2 = \left(\frac{D_2}{D_1}\right)^3 P_1$
Speed Change	$Q_2 = \frac{\text{RPM}_2}{\text{RPM}_1} Q_1$	$H_2 = \left(\frac{\text{RPM}_2}{\text{RPM}_1}\right)^2 H_1$	$P_2 = \left(\frac{\text{RPM}_2}{\text{RPM}_1}\right)^3 P_1$

Where Q = GPM, H = Head, P = BHP, D = Impeller Dia., RPM = Pump Speed

60 Cycle Performance Curves - G&L Pump Series A-C 8300

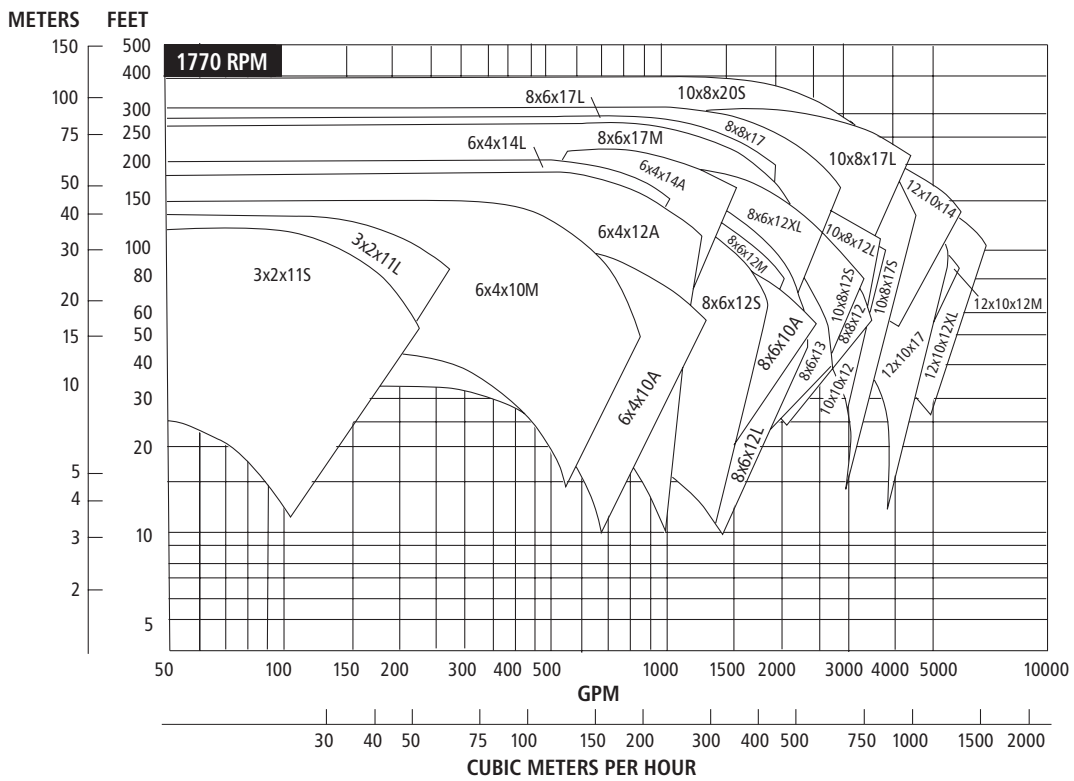
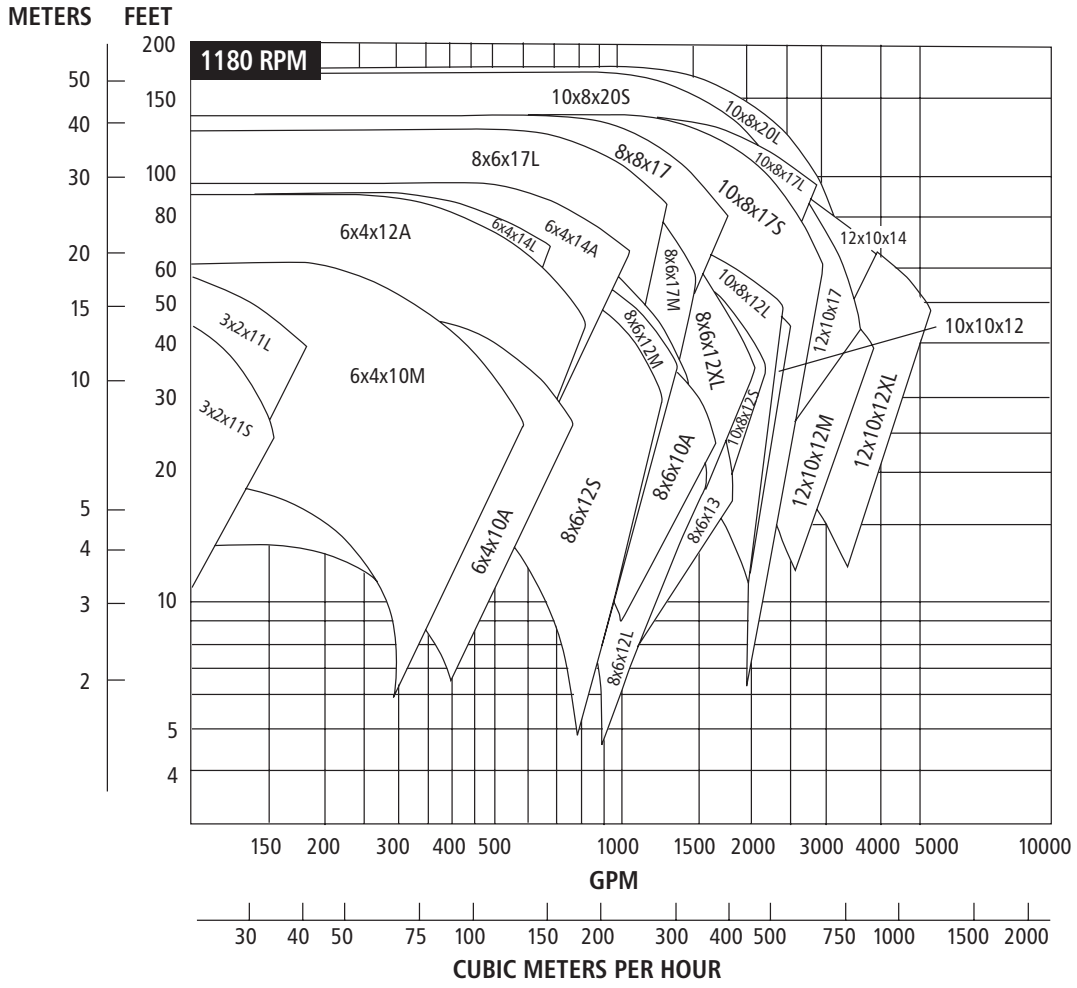

50 Cycle Performance Curves - G&L Pump Series A-C 8300

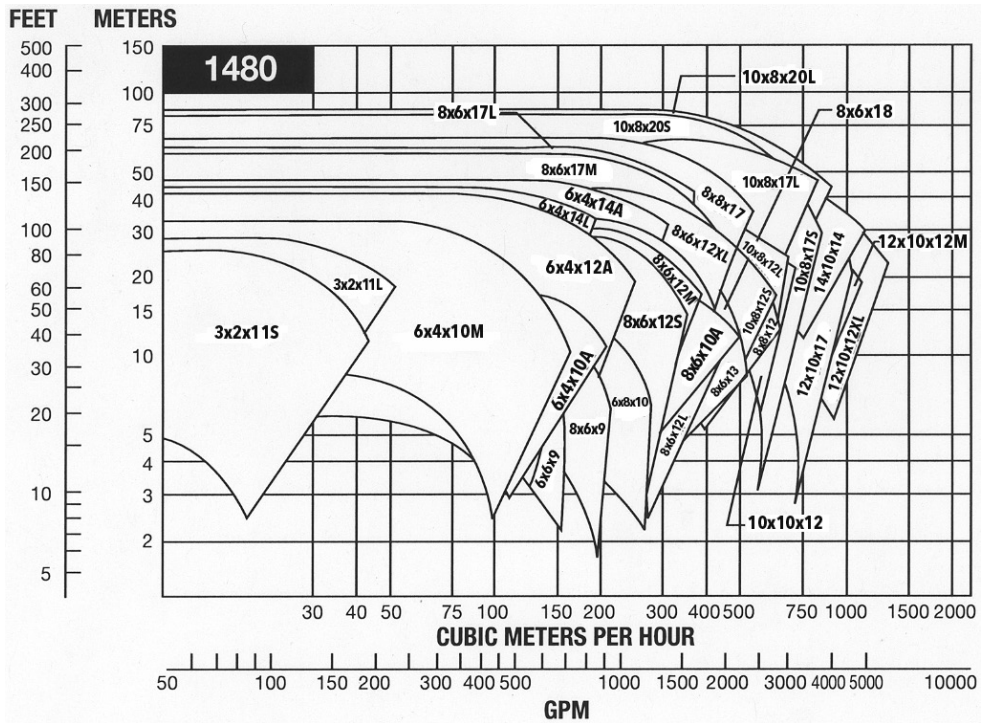

G&L Pump Series A-C 8300 Materials of Construction

Mechanical Seal Mounted on shaft

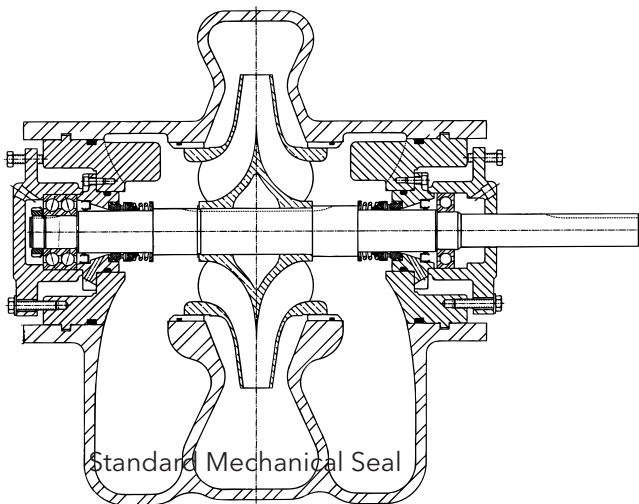

Part Name	Material
	Cast Iron, Bronze Fitted
Casing assembly	Cast iron (ASTM A48 Class 35A)
Casing joint gasket (suction)	Paper (vellumoid 505)
Casing joint gasket (discharge)	Paper (vellumoid 505)
Casing ring	Bismuth Bronze
Shaft	416 Stn. Stl.
Bearing housing	Cast iron (ASTM A48 Class 30A)
Bearing housing	Cast iron (ASTM A48 Class 30A)
Bearing (inboard) ball	Steel
Bearing (outboard) ball	Steel
Stuffing box (mechanical seal)	Cast iron (ASTM A48 Class 30A)
Lip seal (bearing)	Rubber (BUNA-N)
Mechanical seal	Stn. stl., rubber, carbon, ceramic
Capscrew (bearing housing)	Steel, grade 2
Pipe plugs (bearing housing)	Steel
Key, impeller	Stn. stl. (ANSI 416)
Key, coupling	Steel
O-ring (casing ring)	Rubber (BUNA-N)
O-ring (cover plate)	Rubber (BUNA-N)
Retaining ring (impeller)	Steel
Ring retaining (bearing)	Steel
End cap	Steel
Spirol pin (casing ring)	304 SS
Impeller	Bronze (ASTM C87600)

L/D Ratio Construction

The L/D ratio measures the comparable shaft stiffness factor between two pumps where “L” equals the distance between the inboard and outboard bearings and “D” represents the shaft diameter at the impeller. The lower the ratio, the stiffer the shaft. Excessive shaft deflection will shorten mechanical seal life, subject the shaft

to fatigue stress, that could result in shaft failure and increase bearing load with a corresponding reduction in bearing life. As calculated in the table below, the G&L Pump Series A-C 8300 has a L/D ratio that is significantly below a traditional horizontal split case pump.

Pump Size	L = Span Between Bearing to Bearing (Center)	D = Diameter Through Impeller	L/D	L = Span Between Bearing to Bearing (Center)	D = Diameter Through Impeller	L/D
3x2x11S	11.03	1.689	6.5	20.90	1.689	12.4
3x2x11L	11.03	1.689	6.5	20.90	1.689	12.4
6x4x10A	14.56	1.939	7.5	25.25	1.939	13.0
6x4x10M	12.53	1.689	7.4	22.90	1.689	13.6
6x4x12A	12.53	1.689	7.4	22.90	1.689	13.6
6x4x14A	12.53	1.689	7.4	22.90	1.989	13.0
6x4x14L	12.53	1.689	7.4	22.90	1.989	13.0
8x6x10A	18.25	1.939	9.4	29.57	2.439	12.1
8x6x12S	12.53	1.689	7.4	22.90	1.689	13.6
8x6x12M	14.56	1.939	7.5	25.25	1.939	13.0
8x6x12L	12.53	1.689	7.4	22.90	1.689	13.6
8x6x12XL	12.53	1.689	7.4	22.90	1.689	13.6
8x6x13	16.16	1.939	8.3	27.25	1.939	14.1
8x6x17M	16.16	1.939	8.3	27.25	1.939	14.1
8x6x17L	16.16	1.939	8.3	27.25	1.939	14.1
8x8x12	16.16	1.939	8.3	27.25	1.939	14.1
8x8x17	18.59	2.439	7.6	29.90	2.439	12.3
10x8x12S	18.59	2.439	7.6	29.90	2.439	12.3
10x8x12L	18.59	2.439	7.6	29.90	2.439	12.3
10x8x17S	18.59	2.439	7.6	29.90	2.439	12.3
10x8x17L	18.59	2.439	7.6	29.90	2.439	12.3
10x8x20S	18.59	2.439	7.6	29.90	2.439	12.3
10x8x20L	18.59	2.439	7.6	29.90	2.439	12.3
10x10x12	21.59	2.439	8.9	32.90	2.439	13.5
12x10x12M	21.59	2.439	8.9	32.90	2.439	13.5
12x10x12XL	21.59	2.439	8.9	32.90	2.439	13.5
12x10x14	18.59	2.439	7.6	29.90	2.439	12.3
12x10x17	18.59	2.439	7.6	29.90	2.439	12.3

G&L Pump Series A-C 8300 Model - 150 Dimensions

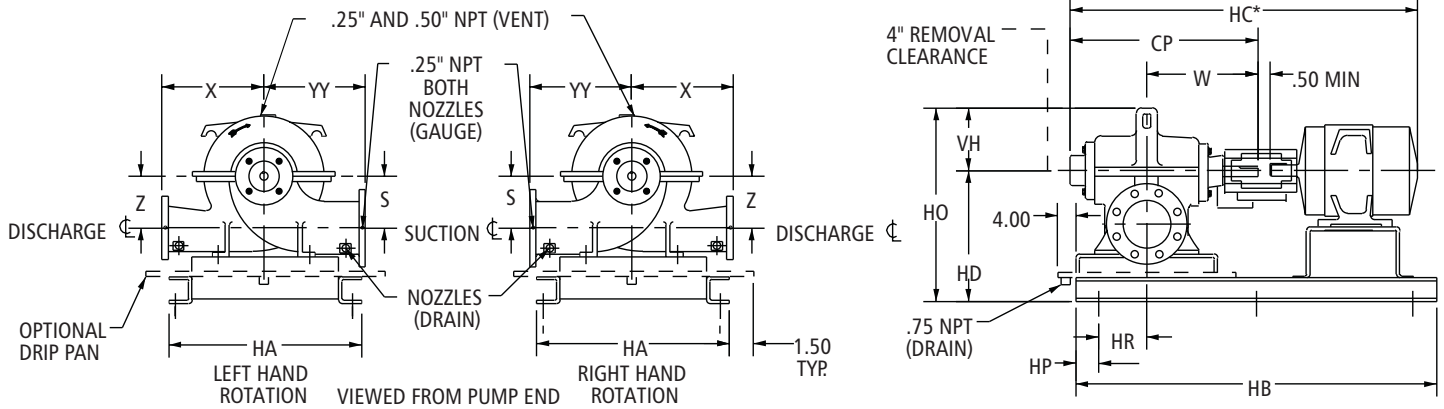

Mechanical Seal Data

Standard Construction

- 175 PSIG (12 BAR) maximum working pressure
- *100 PSIG (7 BAR) maximum suction pressure
125#FF ANSI flange (ANSI A21.10, AWWA C110 & ANSI B16.1 class 125)
- Type 21, BUNA/Carbon-ceramic, *100 PSIG (7 BAR) maximum suction pressure, from -20° to 225°F (-29° to 107°C)
- Optional seals:
 - Type 21, EPR/carbon-ceramic, *100 PSIG (7 BAR) maximum suction pressure, from -20° to 250°F (-29° to 121°C)
 - Type 21, EPR/carbon-tungsten carbide, *100 PSIG (7 BAR) maximum suction pressure, from -20° to 250°F (-29° to 121°C)

Internally Self-Flushing Seal:

The G&L Pump Series A-C 8300 features internally self-flushing mechanical seals. This innovative design, and industry standard, insures maximum seal life lubrication, heat dissipation and debris removal - all without vulnerable, external flush lines and filter kits that can clog and result in seal failure. With the G&L Pump Series A-C 8300 internally self-flushing seal design, as much as 25% of the total pump flow continuously flushes the seal faces compared to only a few GPM for conventional stuffing box mounted mechanical seals. Seals remain cooler and unwanted debris is flushed away from the mechanical seal faces resulting in longer mechanical seal life.

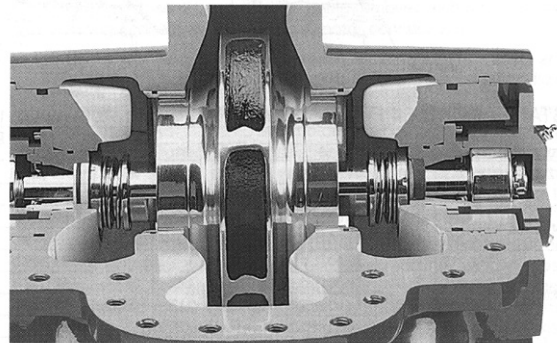

Standard: 125# FF ANSI Flange (ANSI A21.10, AWWA C110 & ANSI B16.1 Class 125)

PUMP SIZE	MOTOR FRAME	DIMENSIONS - INCHES (MM)													
		HA	HB	HP	HR	CP	HC* MAX	HD	HO	S & Z	VH	VH1	W	X	YY
3x2x11S, L	143-215	20.00 (508)	44.00 (1118)	6.00 (152)	2.25 (57)	18.62 (473)	39 (991)	15.25 (388)	22.05 (560)	5.50 (140)	6.80 (173)	-	11.31 (287)	9.00 (229)	10.00 (254)
	254-365		54.00 (1372)				50 (1270)								
6x4x10A	182-215	21.50 (546)	48.00 (1219)	6.00 (152)	2.88 (73)	19.93 (506)	50 (1270)	18.25 (464)	25.94 (659)	7.00 (178)	7.69 (195)	-	12.19 (310)	11.50 (292)	12.00 (305)
	254-324		54.00 (1372)				59 (1499)								
6x4x10M	182-215	24.00 (610)	48.00 (1219)	6.00 (152)	4.62 (117)	22.81 (579)	43 (1092)	18.25 (464)	26.12 (664)	6.50 (165)	7.88 (200)	-	13.50 (343)	11.50 (292)	13.00 (330)
	254-326		58.00 (1473)				52 (1321)								
	364-405		64.00 (1626)				61 (1549)								
	444-445		76.00 (1930)				68 (1727)								
6x4x12A	215	24.00 (610)	48.00 (1219)	6.00 (152)	4.62 (117)	22.81 (579)	43 (1092)	18.25 (464)	26.81 (681)	7.38 (188)	8.56 (218)	-	13.50 (343)	11.50 (292)	13.00 (330)
	254-326		58.00 (1473)				52 (1321)								
	364-365		64.00 (1626)				61 (1549)								
6x4x14A	215-256	24.00 (610)	48.00 (1219)	6.00 (152)	3.25 (83)	20.62 (524)	45 (1143)	19.52 (489)	28.50 (723)	7.75 (197)	9.20 (234)	-	12.56 (319)	11.50 (292)	13.00 (330)
	284-365		58.00 (1473)				54 (1372)								
	404-405		68.00 (1727)				60 (1524)								
	444		76.00 (1930)				64 (1625)								
6x4x14L	182-256	24.00 (610)	48.00 (1219)	6.00 (152)	3.25 (83)	20.62 (524)	45 (1143)	19.25 (489)	28.87 (733)	7.75 (197)	9.62 (244)	-	12.56 (319)	11.50 (292)	13.00 (330)
	284-365		58.00 (1473)				54 (1372)								
8x6x10A	215-286	24.00 (610)	58.00 (1473)	6.00 (152)	10.75 (273)	29.19 (741)	56.38 (1432)	21.25 (540)	30.50 (775)	8.25 (210)	9.25 (235)	-	17.58 (447)	12.50 (318)	12.50 (318)
	324-326		64.00 (1626)				58.38 (1438)								
	364-365		68.00 (1727)				60.38 (1534)								
8x6x12 S, L, XL	182-256	21.50 (546)	48.00 (1219)	6.00 (152)	3.25 (83)	20.62 (524)	45 (1143)	21.25 (540)	28.75 (730)	9.00 (229)	9.60 (244)	-	12.56 (319)	14.00 (356)	14.00 (356)
	284-326		54.00 (1372)				51 (1295)								
	364-365		60.00 (1524)				54 (1372)								
8x6x12M	254-326	24.00 (610)	58.00 (1473)	6.00 (152)	4.63 (118)	22.81 (579)	53 (1346)	21.25 (540)	30.75 (784)	9.00 (229)	9.60 (244)	-	13.50 (343)	14.00 (356)	14.00 (356)
	364-405		64.00 (1626)				61 (1549)								
	444-447		76.00 (1930)				71 (1803)								
8x6x13	254-326	24.00 (610)	62.00 (1575)	6.00 (152)	5.63 (143)	26.19 (665)	56 (1422)	20.00 (591)	29.40 (747)	8.00 (203)	9.40 (239)	-	16.06 (408)	13.00 (330)	15.50 (394)
	364-405		68.00 (1727)				65 (1651)								
8x6x17 M, L	284-326	24.00 (610)	62.00 (1575)	6.00 (152)	5.63 (143)	26.19 (665)	56 (1422)	21.25 (540)	33.00 (838)	9.00 (229)	11.75 (299)	-	16.06 (408)	14.00 (356)	16.00 (406)
	364-405		68.00 (1727)				65 (1651)								
	444-445		76.00 (1930)				71 (1803)								
8x8x12	254-326	24.00 (610)	62.00 (1575)	6.00 (152)	5.63 (143)	26.19 (665)	56 (1422)	20.00 (508)	30.25 (768)	8.00 (203)	10.25 (260)	-	16.06 (408)	14.00 (356)	16.50 (419)
	364-405		68.00 (1727)				65 (1651)								
8x8x17	324-365	24.00 (610)	66.00 (1676)	6.00 (152)	7.00 (178)	28.94 (725)	62 (1575)	21.75 (553)	33.75 (857)	9.50 (241)	12.00 (305)	-	17.56 (446)	15.00 (381)	16.50 (419)
	404-445	29.40 (747)	76.00 (1930)	5.00 (127)	8.00 (203)		74 (1880)	23.75 (603)	35.75 (908)						
	447-449		86.00 (2184)		82 (2083)										
10x8x12 S, L	254-286	24.00 (610)	62.00 (1575)	6.00 (152)	7.00 (178)	28.94 (735)	56 (422)	21.50 (546)	32.00 (813)	8.50 (216)	10.50 (267)	-	17.56 (446)	14.00 (356)	17.00 (432)
	324-365		66.00 (1676)	5.00 (127)	8.00 (203)		62 (1575)								
	404-445	29.40 (747)	76.00 (1930)		74 (1880)		23.25 (591)	34.00 (864)							
10x8x17 S, L	324-365	24.00 (610)	66.00 (1676)	6.00 (152)	7.00 (178)	28.94 (735)	62 (1575)	23.25 (591)	36.06 (916)	10.00 (254)	12.81 (325)	-	17.56 (446)	16.00 (406)	18.00 (457)
	404-445	29.40 (747)	76.00 (1930)	5.00 (127)	8.00 (203)		74 (1880)	25.25 (641)	38.06 (967)						
	447-449		86.00 (2184)		82 (2083)										
10x8x20 S, L	324-365	26.00 (660)	66.00 (1676)	6.00 (152)	7.00 (178)	28.94 (735)	62 (1575)	27.25 (692)	49.50 (1257)	14.00 (356)	15.44 (392)	22.25 (565)	17.56 (446)	18.00 (457)	20.00 (508)
	404-445	31.40 (798)	76.00 (1930)	5.00 (127)	8.00 (203)		74 (1880)	29.25 (743)	51.50 (1308)						
	447-449		86.00 (2184)		82 (2083)										
12x10x12	284-365	24.00 (610)	68.00 (1727)	6.00 (152)	8.50 (216)	31.94 (811)	68 (1727)	22.50 (572)	33.69 (856)	9.00 (229)	11.19 (284)	-	19.06 (484)	16.00 (406)	18.00 (457)
	404-445	29.40 (747)	80.00 (2032)	5.00 (127)	9.50 (241)		81 (2057)	24.50 (622)	35.69 (907)						
1210x12 M, XL	284-365	24.00 (610)	68.00 (1727)	6.00 (152)	8.50 (216)	31.94 (811)	68 (1727)	24.50 (622)	36.00 (914)	10.00 (254)	11.50 (292)	-	19.06 (484)	16.00 (406)	19.00 (483)
	404-445	29.40 (747)	80.00 (2032)	5.00 (127)	9.50 (241)		81 (2057)	26.50 (673)	38.00 (965)						
12x10x14	324-365	24.00 (610)	66.00 (1676)	6.00 (152)	7.00 (178)	28.94 (735)	62 (1575)	25.25 (641)	38.69 (983)	11.00 (280)	13.44 (341)	-	17.56 (446)	18.00 (457)	20.00 (508)
	404-445	29.40 (747)	76.00 (1930)	5.00 (127)	8.00 (203)		74 (1880)	27.25 (692)	40.69 (1034)						
	447-449		86.00 (2184)		82 (2083)										
12x10x17	324-365	24.00 (610)	66.00 (1676)	6.00 (152)	7.00 (178)	28.94 (735)	62 (1575)	25.25 (641)	38.69 (983)	11.00 (280)	13.44 (341)	-	17.56 (446)	18.00 (457)	20.00 (508)
	404-445	29.40 (747)	76.00 (1930)	5.00 (127)	8.00 (203)		74 (1880)	27.25 (692)	40.69 (1034)						
	447-449		86.00 (2184)		82 (2083)										

Not for construction unless certified.

Engineering Specification for G&L Pump Series A-C 8300

Base Mounted Double Suction Pumps

Double Suction, Horizontal Split Case Pumps (Base Mounted):

A. Manufacturer:

Contractor shall furnish and install new double suction horizontal split case pumps for water transport and boosting applications as indicated on the drawings. Pumps shall be the G&L Pump Series A-C 8300 as manufactured by G&L Pumps under base bid. Pumps shall meet types, sizes, capacities and characteristics as scheduled on the Equipment Schedule drawings.

B. Double Suction Horizontal Split Case Pump (Base Mounted):

1. The pumps shall be long coupled, base mounted, single stage, double suction, horizontally split case design, in cast iron bronze fitted construction specifically designed and guaranteed for quiet operation. Suitable standard operations at 225°F (107°C) and 175 PSIG working pressure. Working pressures shall not be de-rated at temperatures up to 250°F (121°C). The pump internals shall be capable of being serviced without disturbing the upper casing half and system piping.
2. A bearing housing shall supply support for a pair of heavy-duty regreasable ball bearings. An inboard single row bearing will absorb thermal expansive forces while an outboard double row bearing will be clamped in place to absorb both radial and thrust loads and keep the rotating element in proper axial alignment. Bearings shall be replaceable without disturbing the system piping, the upper casing half, and shall be regreasable without removal of the bearings from the bearing housing.
3. The impeller shaft shall be a solid 416 stainless steel shaft.
4. Pump shall be equipped with a pair of internally flushed mechanical seal assemblies in direct contact with the pump shaft. Seal assemblies shall be Type 21 having a stainless steel housing, BUNA bellows and seat gasket, stainless steel spring, and be of carbon-ceramic design with the carbon face rotating against a stationary ceramic face.
5. Impeller shall be of the enclosed double suction type made of ASTM B584-876 bronze, both hydraulically and dynamically balanced to ANSI/HI 1.1-1.5-1994, section 1.4.6.1.3.1, figure 1.106, balance grade G6.3 keyed to the shaft and fixed in the axial position.
6. A flexible type coupling, capable of absorbing torsional vibration, shall be employed between the pump and motor. On variable speed applications the coupler sleeve should be constructed of an SPDM material to maximize performance life.
7. The coupling shall be shielded by a dual rated ANSI B15.1, Section 8 and OSHA 1910.219 compliant coupling guard and contain viewing windows for inspection of the coupling.
8. Pump volute shall be of a cast iron (rated for 175 PSIG max. WP) axially-split design with flanges (175 PSIG drilled for 125# ANSI companion flanges) and mounting feet

integral cast into the bottom half of the casing. Suction and discharge flanges shall be on a common centerline in both the horizontal and vertical planes, and the volute shall include bronze casing wear rings, priming port, gauge ports at nozzles, and vent and drain ports. The upper half casing shall be capable of being removed without disturbing piping connections or electrical motor connections.

9. Pump seal flushing shall be internal within the pump casing and shall flush the seal at a rate equal to 25% of the total pump flow.
10. Motors shall meet scheduled horsepower, speed, voltage and enclosure design. Pump and motors shall be factory aligned, and shall be realigned after installation by the manufacturer's representative. Motors shall be non-overloading at any point on the pump curve and shall meet NEMA specifications and conform to the standards outlined in EISA 2007.
11. Base plate shall be of structural steel or fabricated steel channel with fully enclosed sides and ends, and securely welded cross members. The grouting area shall be fully open. The combined pump and motor base plate shall be sufficiently stiff as to limit the susceptibility of vibration. The minimum base plate stiffness shall conform to ANSI/HI 1.3.4-1997 for Horizontal Baseplate Design standards.
12. Base shall be capable of being field grouted.
13. Pump rotation shall be righthand or lefthand as viewed from the pump end.
14. Pump manufacturer shall be ISO9001 certified.
15. The seismic capability of the pump shall allow it to withstand a horizontal load of 0.5g, excluding piping and/or fasteners used to anchor the pump to mounting pads or to the floor, without adversely affecting pump operation.
16. Each pump shall be factory hydrostatically tested per Hydraulic Institute standards and name-plated before shipment. It shall then be thoroughly cleaned and painted with at least one coat of high grade paint prior to shipment.

C. Accessories:

1. Where noted on schedule pumps shall be provided with internal bronze pump wear rings, special shaft materials, or special spacer couplers.
2. Where noted on schedule either balanced or unbalanced seals of EPR carbon/ceramic seals, EPR tungsten/carbide seal, or packing gland material should be used in lieu of the standard seal.
3. Where noted on schedule pumping equipment may require one or all of the following tests: certified lab tests (unwitnessed), ANSI/Hydraulic Institute Standard 14.6 Acceptance Grade 2B tests, or witnessed tests.



Xylem Inc.
8200 N. Austin Avenue
Morton Grove, Illinois 60053
Phone: (847) 966-3700
Fax: (847) 965-8379
www.xyleminc.com