

WRAPFLEX®  
Talk About Simple!

FALK POWERED FALK POWERED FALK POWERED FALK POWERED FALK POWERED

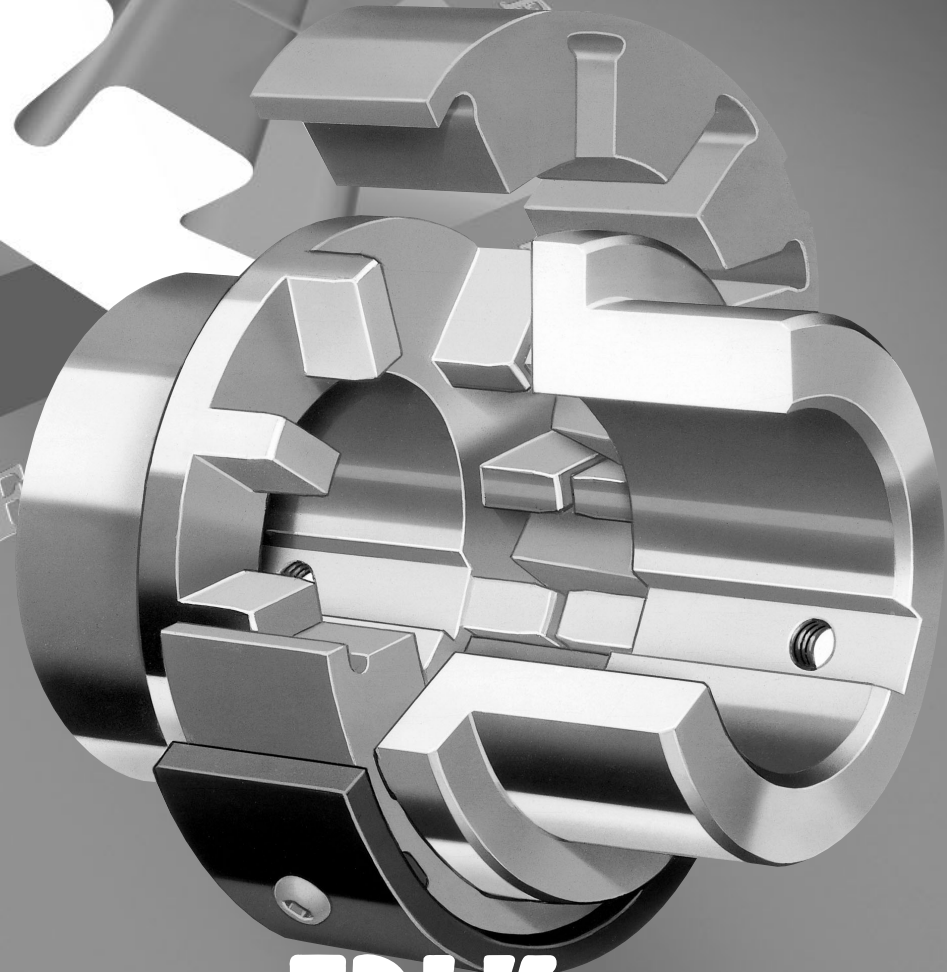

**FALK®**

# WRAPFLEX®

## Now there's a simple way to increase productivity

- 9 sizes
- Torque range: 133,000 lb.in. (15 028Nm)
  - Bore capacity: 7¼" (186mm)
  - "Replace in place"
  - Non-lubricated/low maintenance
  - 3-Year Heavy-Duty Warranty



Ever think that keeping your production lines running more profitably could be as simple as replacing a light bulb or opening a can with a pop-top?

Quick, easy installation and replacement set new standards for reduced downtime. Because motors or drives don't need to be moved, our "replace in place" elements even eliminate the need for time-consuming realignment, further reducing downtime. Available in close-coupled and spacer designs, Wrapflex couplings accommodate up to 7¼" (186 mm) shafts and torque loads up to 133,000 lb.in. (15 028 Nm). For simplicity and cost-effectiveness over the life of your coupling, it just doesn't get any easier than this – Wrapflex couplings from Falk.

### Low initial cost

- Advanced manufacturing methods and innovative material allow us to offer you higher capacity ratings at a more competitive price than ever before possible.
- Initial investment protected by the industry's first, standard 3-Year Heavy-Duty Warranty.

### Easy to install

- The compound root radius in the element teeth (patent applied for) increases flexibility for easier and quicker assembly.
- Can be blind assembled from either direction.

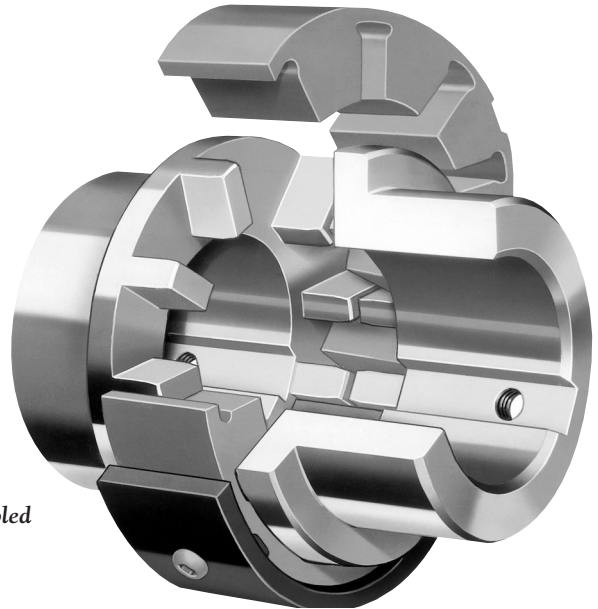

R10 Close-Coupled

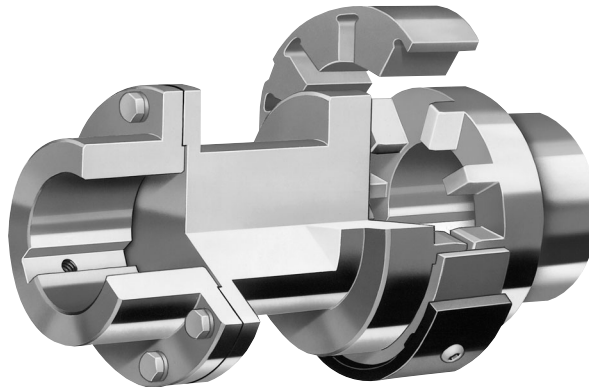

R35 Half-Spacer



#### Replace in place

- Design allows quick and easy element replacement.
- There's no need to remove hubs or realign motors or drives, reducing downtime.

#### No maintenance needed

- Non-lubricated design of the tough, flexible polyurethane element reduces periodic maintenance costs.

#### Protects equipment

- Patent applied for design of the flexible element minimizes effects of misalignment for improved performance and life.

- Hub teeth machined with special nose radius (patent applied for) for better tooth-to-tooth contact.

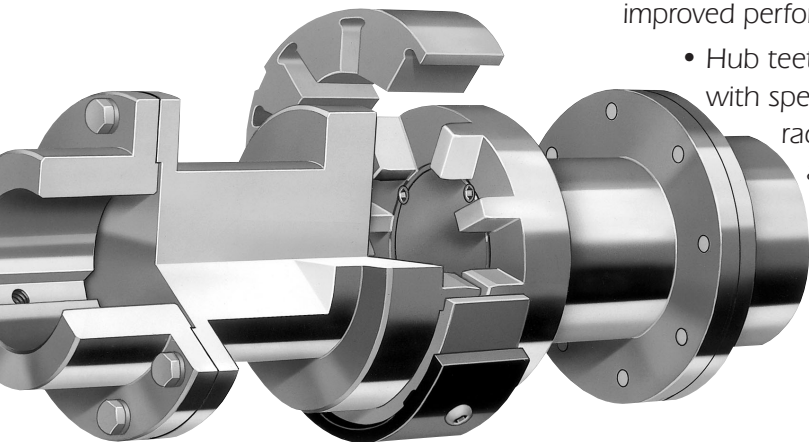

R31 Full-Spacer

#### Tough, long-lasting

- Polyurethane element has excellent wear and chemical resistance, and a operating temperature of  $-40^{\circ}\text{C}$  ( $-40^{\circ}\text{F}$ ) to  $95^{\circ}\text{C}$  ( $200^{\circ}\text{F}$ ).
- Hubs made from carbon steel for maximum strength.
- Weather-resistant, high-grade nylon cover is standard.
- Optional carbon steel covers with black epoxy coating for highly corrosive, severe-duty applications. (Standard for sizes 60-80.)

#### Safety first

- Two stainless steel button-head cap screws, positioned  $180^{\circ}$  apart, prevent relative motion between cover and element and provide a positive means of retaining the cover to the element.
- Flexible element is retained after failure, helping minimize the potential for damage or personal injury.

#### Quick and easy retrofits

- Compact design eliminates the need for coupling guard redesign on existing applications.
- Stock finished bores in popular sizes and taper bores, which accept O.D. and TaperLock bushings, are available from our worldwide distribution network for off-the-shelf availability.

# WRAPFLEX® Selection Guide

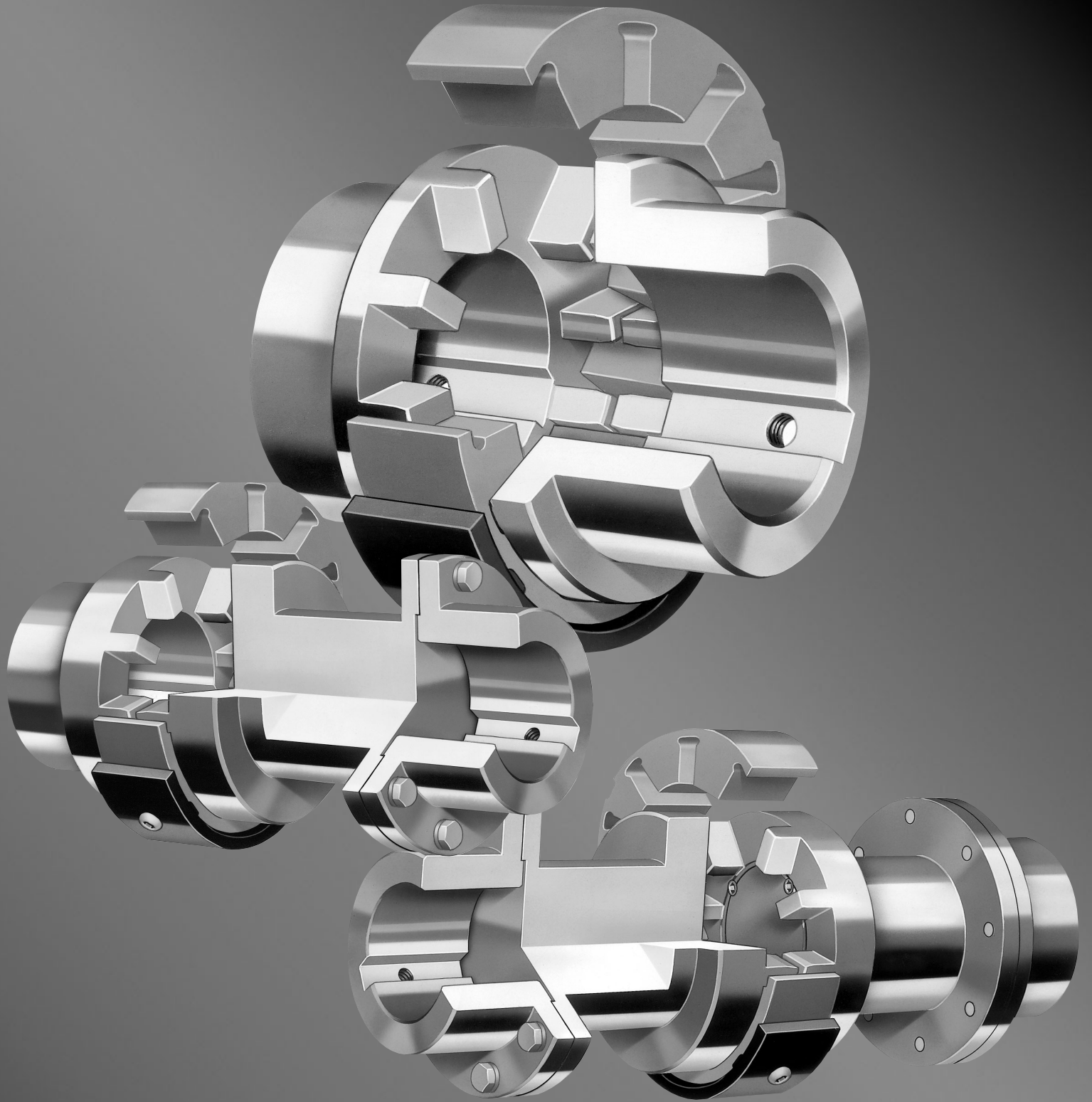







# Selection Guide 491-110, June 2004

## Wrapflex Quick Selection Method

1. Determine Service Factor — Refer to Table 1 or 4 for motor or turbine driven applications. See Table 5 for Engine Drives.
2. Determine Equivalent Horsepower:  
Refer to Table 2 — Under the actual hp required and opposite the service factor, read the equivalent hp.
3. Determine Coupling Size:
- A. Refer to Table 3 — Trace horizontally from the required speed to a hp value equal to or larger than the equivalent hp determined in Step 2. Read the coupling size at the top of the column.
- B. Check shaft diameters against coupling maximum bores shown in Table 3 and on Page 8 for the correct coupling size selected.
- C. In Table 3, check the required speed against the allowable speed shown below the correct coupling size selected.
4. Determine Coupling Dimensional Requirements:
- A. Determine application/design shaft spacing and check application dimension requirements against selected coupling type dimensions shown on Pages 8 thru 12. Confirm sufficient clearances for coupling.
5. Confirm that application ambient operating temperatures are between -40°C (-40°F) to 95°C (200°F). For applications requiring Service Factor above 1.5 and temperatures above 79°C (175°F), consult Falk Engineering for selection assistance or optional high temperature elements.

**SERVICE FACTORS** are a guide, based on experience, of the ratio between coupling catalog rating and system characteristics. The system characteristics are best measured with a torque meter.

**TABLE 1 — Service Factors**

Torque Demands Driven Machine	Typical applications for electric motor or turbine driven equipment	Typical Service Factor
	Constant torque such as Centrifugal Pumps, Blowers, and Compressors.	1.0
	Continuous duty with some torque variations including Plastic extruders, Forced Draft Fans.	1.5
	Light shock loads from Metal Extruders, Cooling Towers, Cane Knife, Log Haul.	2.0
	Moderate shock loading as expected from a Car Dumper, Stone Crusher, Vibrating Screen.	2.5
	Heavy shock load with some negative torques from Roughing Mills, Reciprocating Pumps, Compressors, Reversing Runout Tables.	3.0
	Applications like Reciprocating Compressors with frequent torque reversals, which do not necessarily cause reverse rotations.	Refer to Falk

**TABLE 2 — Equivalent Horsepower = (Actual hp x Service Factor)**

Service Factor ‡	Actual HP																									
	3/4	1	1½	2	3	5	7½	10	15	20	25	30	40	50	60	75	100	125	150	200	250	300	350	400	450	500
<b>1.0</b>	.75	1.0	1.5	2.0	3.0	5.0	7.5	10	15	20	25	30	40	50	60	75	100	125	150	200	250	300	350	400	450	500
<b>1.25</b>	.94	1.25	1.9	2.5	3.8	6.3	9.4	12.5	19	25	31	38	50	63	75	94	125	156	188	250	312	375	438	500	563	625
<b>1.5</b>	1.1	1.5	2.3	3.0	4.5	7.5	11.3	15	23	30	38	45	60	75	90	113	150	188	225	300	375	450	525	600	675	750
<b>1.75</b>	1.3	1.8	2.6	3.5	5.3	8.8	13.1	18	26	35	44	53	70	88	105	131	175	219	262	350	438	525	613	700	787	875
<b>2.0</b>	1.5	2.0	3.0	4.0	6.0	10.0	15.0	20	30	40	50	60	80	100	120	150	200	250	300	400	500	600	700	800	900	1000
<b>2.5</b>	1.9	2.5	3.8	5.0	7.5	12.5	18.8	25	38	50	63	75	100	125	150	187	250	312	375	500	625	750	875	1000	1125	1250
<b>3.0</b>	2.3	3.0	4.5	6.0	9.0	15.0	22.5	30	45	60	75	90	120	150	180	225	300	375	450	600	750	900	1050	1200	1350	1500
<b>3.5</b>	2.6	3.5	5.3	7.0	10.5	17.5	26.2	35	52	70	87	105	140	175	210	262	350	437	525	700	875	1050	1225	1400	1575	1750

‡ For service factors not listed, Equivalent hp = Actual hp x Service Factor.

TABLE 3 — Falk "Wrapflex" Coupling Quick Selection Chart

	5R	10R	20R	30R	40R	50R	60R	70R	80R
Max Bore (Inches)	1.625	1.875	2.375	2.875	3.375	4.125	5.250	6.125	7.250
Max Speed	4500 rpm	4500 rpm	4500 rpm	4500 rpm	3600 rpm	3000 rpm	2500 rpm	2100 rpm	1800 rpm
Torque (lb-in)	550	1150	2800	4600	9100	22,200	35,500	70,900	133,000
HP/100 rpm	0.87	1.82	4.44	7.3	14.4	35.2	56.3	112.5	211.0
RPM	HP Ratings								
4500	39.3	82.1	200	328					
3600	31.4	65.7	160	263	520				
3000	26.2	54.7	133	219	433	1057			
2500	21.8	45.6	111	182	361	881	1408		
2100	18.3	38.3	93.3	153	303	740	1183	2362	
1800	15.7	32.8	80.0	131	260	634	1014	2025	3798
1750	15.3	31.9	77.7	128	253	616	986	1969	3693
1450	12.7	26.5	64.4	106	209	511	817	1631	3060
1170	10.2	21.3	52.0	85.4	169	412	659	1316	2469
1000	8.7	18.2	44.4	73.0	144	352	563	1125	2110
870	7.6	15.9	38.7	63.5	126	306	490	979	1836
720	6.3	13.1	32.0	52.6	104	254	406	810	1519
650	5.7	11.9	28.9	47.4	93.9	229	366	731	1372
580	5.1	10.6	25.8	42.3	83.7	204	327	652	1224
520	4.5	9.5	23.1	38.0	75.1	183	293	585	1097
420	3.7	7.7	18.7	30.7	60.6	148	237	472	886
350	3.1	6.4	15.5	25.5	50.5	123	197	394	739
280	2.4	5.1	12.4	20.4	40.4	98.6	158	315	591
230	2.0	4.2	10.2	16.8	33.2	81.0	130	259	485
190	1.7	3.5	8.4	13.9	27.4	66.9	107	214	401
155	1.4	2.8	6.9	11.3	22.4	54.6	87.3	174	327
125	1.1	2.3	5.6	9.1	18.0	44.0	70.4	141	264
100	.87	1.8	4.4	7.3	14.4	35.2	56.3	112	211
84	.73	1.5	3.7	6.1	12.1	29.6	47.3	94.5	177
68	.59	1.2	3.0	5.0	9.8	24.0	38.3	76.5	143
56	.49	1.02	2.5	4.1	8.1	19.7	31.5	63.0	118
45	.39	.82	2.0	3.3	6.5	15.9	25.3	50.6	95.0
37	...	.68	1.6	2.7	5.3	13.0	20.8	41.6	78.1
30	...	.55	1.3	2.2	4.3	10.6	16.9	33.7	63.3
25	...	...	1.1	1.8	3.6	8.8	14.1	28.1	52.8
20	...	...	.89	1.5	2.9	7.0	11.3	22.5	42.2
16.5	...	...	.73	1.2	2.4	5.8	9.29	18.6	34.8
13	...	...	.58	.95	1.9	4.6	7.32	14.6	27.4

# Service Factors

**TABLE 4 — Flexible Coupling Service Factors for Motor ♦ and Turbine Drives**

Service factors listed are typical values based on normal operation of the drive systems.

Alphabetical listing of applications		Alphabetical listing of industries	
	Service Factor		Service Factor
<b>AERATOR</b> .....	2.0	<b>AGGREGATE PROCESSING, CEMENT, MINING KILNS; TUBE, ROD AND BALL MILLS</b>	
<b>AGITATORS</b>		Direct or on L.S. shaft of	
Vertical and Horizontal		Reducer, with final drive	
Screw, Propeller, Paddle .....	1.0	Machined Spur Gears .....	2.0
<b>BARGE HAUL PULLER</b> .....	1.5	Single Helical or	
<b>BLOWERS</b>		Herringbone Gears .....	1.75
Centrifugal .....	1.0	Conveyors, Feeders, Screens,	
Lobe or Vane .....	1.25	Elevators, .....	See General Listing
<b>CAR DUMPERS</b> .....	2.5	Crushers, Ore or Stone .....	2.5
<b>CAR PULLERS</b> .....	1.5	Dryer, Rotary .....	1.75
<b>CLARIFIER OR CLASSIFIER</b> .....	1.0	Grizzly .....	2.0
<b>COMPRESSORS</b>		Hammermill or Hog .....	1.75
Centrifugal .....	1.0	Tumbling Mill or Barrel .....	1.75
Rotary, Lobe or Vane .....	1.25	<b>BREWING AND DISTILLING</b>	
Rotary, Screw .....	1.0	Bottle and Can	
Reciprocating		Filling Machines .....	1.0
Direct Connected .....	Refer to Falk	Brew Kettle .....	1.0
Without Flywheel .....	Refer to Falk	Cookers, Continuous Duty .....	1.25
*With Flywheel and Gear		Lauter Tub .....	1.5
between Compressor		Mash Tub .....	1.25
and Prime Mover		Scale Hopper, Frequent Peaks .....	1.75
1 cylinder, single acting .....	3.0	<b>CLAY WORKING INDUSTRY</b>	
1 cylinder, double acting .....	3.0	Brick Press, Briquette Machine,	
2 cylinders, single acting .....	3.0	Clay Working Machine,	
2 cylinders, double acting .....	3.0	Pug Mill .....	1.75
3 cylinders, single acting .....	3.0	<b>DREDGES</b>	
3 cylinders, double acting .....	2.0	Cable Reel .....	1.75
4 or more cyl., single act. ....	1.75	Conveyors .....	1.25
4 or more cyl., double act. ....	1.75	Cutter head, Jig Drive .....	2.0
▲ <b>CONVEYORS</b>		Maneuvering Winch .....	1.5
Apron, Assembly, Belt, Chain,		Pumps (uniform load) .....	1.5
Flight, Screw .....	1.0	Screen Drive, Stacker .....	1.75
Bucket .....	1.25	Utility Winch .....	1.5
Live Roll, Shaker and		<b>FOOD INDUSTRY</b>	
Reciprocating .....	3.0	Beet Slicer .....	1.75
▲ <b>CRANES AND HOIST</b>		Bottling, Can Filling Machine .....	1.0
Main Hoist .....	1.75	Cereal Cooker .....	1.25
Skip Hoist .....	1.75	Dough Mixer, Meat Grinder .....	1.75
Slope .....	1.5	<b>LUMBER</b>	
Bridge, Travel or Trolley .....	1.75	Band Resaw .....	1.5
<b>DYNAMOMETER</b> .....	1.0	Circular Resaw, Cut-off .....	1.75
<b>ELEVATORS</b>		Edger, Head Rig, Hog .....	2.0
Bucket, Centrifugal Discharge .....	1.25	Gang Saw	
Freight or Passenger .....	Not	(Reciprocating) .....	Refer to Falk
Approved		Log Haul .....	2.0
Gravity Discharge .....	1.25	Planer .....	1.75
<b>ESCALATORS</b> .....	Not Approved	Rolls, Non-Reversing .....	1.25
<b>EXCITER, GENERATOR</b> .....	1.0	Rolls, Reversing .....	2.0
<b>EXTRUDER, PLASTIC</b> .....	1.5	Sawdust Conveyor .....	1.25
<b>FANS</b>		Slab Conveyor .....	1.75
Centrifugal .....	1.0	Sorting Table .....	1.5
Cooling Tower .....	2.0	Trimmer .....	1.75
Forced Draft — Across the		<b>METAL ROLLING MILLS</b>	
Line start .....	1.5	Coilers (Up or Down) Cold	
Forced Draft Motor		Mills only .....	1.5
Driven thru fluid or		Coilers (Up or Down) Hot	
electric slip clutch .....	1.0	Mills only .....	2.0
Gas Recirculating .....	1.5	Coke Plants	
Induced Draft with damper		Pusher Ram Drive .....	2.5
control or blade cleaner .....	1.25	Door Opener .....	2.0
Induced Draft without controls .....	2.0	Pusher or Larry Car	
<b>FEEDERS</b>		Traction Drive .....	3.0
Apron, Belt, Disc, Screw .....	1.0	Continuous Caster .....	1.75
Reciprocating .....	2.5	Cold Mills —	
<b>GENERATORS</b>		Strip Mills .....	Refer to Falk
Even Load .....	1.0	Temper Mills .....	Refer to Falk
Hoist or Railway Service .....	1.5	Cooling Beds .....	1.5
Welder Load .....	2.0	Drawbench .....	2.0
♦ For engine drives, refer to Table 5. Electric motors, generators, engines, compressors and other machines fitted with sleeves or straight roller bearings usually require limited end float couplings. If in doubt, provide axial clearances and centering forces to Falk for a recommendation.		Feed Rolls - Blooming Mills .....	3.0
* For balanced opposed design, refer to Falk.		Furnace Pushers .....	2.0
▲ If people are occasionally transported, refer to Falk for the selection of the proper size coupling.		Hot and Cold Saws .....	2.0
♣ For high peak load applications (such as Metal Rolling Mills) refer to Falk.		Hot Mills .....	
		Strip or Sheet Mills .....	Refer to Falk
		Reversing Blooming .....	Refer to Falk
		or Slabbing Mills .....	Refer to Falk
		Edger Drives .....	Refer to Falk
		Ingot Cars .....	2.0
		Manipulators .....	3.0
		Merchant Mills .....	Refer to Falk
		Mill Tables	
		Roughing Breakdown	
		Mills .....	3.0
		Hot Bed or Transfer,	
		non-reversing .....	1.5
		Runout, reversing .....	3.0
		Runout, non-reversing,	
		non-plugging .....	2.0
		Reel Drives .....	1.75
		Rod Mills .....	Refer to Falk
		Screwdown .....	2.0
		Seamless Tube Mills	
		Piercer .....	3.0
		Thrust Block .....	2.0
		Tube Conveyor Rolls .....	2.0
		Reeler .....	2.0
		Kick Out .....	2.0

**TABLE 5 — Engine Drive Service Factors ▼**

Service Factors for engine drives are those required for applications where good flywheel regulation prevents torque fluctuations greater than ±20%. For drives where torque fluctuations are greater or where the operation is near a serious critical or torsional vibration, a mass elastic study is necessary.

No. of Cylinders	4 or 5 ▼					6 or more ▼				
	1.0	1.25	1.5	1.75	2.0	1.0	1.25	1.5	1.75	2.0
<b>Table 4 S.F.</b>	1.0	1.25	1.5	1.75	2.0	1.0	1.25	1.5	1.75	2.0
<b>Engine S.F.</b>	2.0	2.25	2.5	2.75	3.0	1.5	1.75	2.0	2.25	2.5

▼ To use Table 5, first determine application service factor from Table 4. Use that factor to determine ENGINE Service Factor from Table 5. When service factor from Table 4 is greater than 2.0, or where 1, 2, or 3 cylinder engines are involved, refer complete application details to Falk Engineering.

# Type R10

## Close Coupled Coupling/Dimensions — Inches

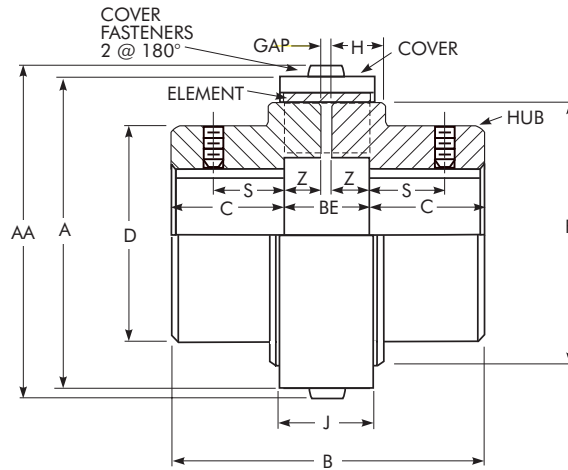

DIMENSIONS — INCHES †

SIZE ★	Torque Rating lb-in	Allow Speed rpm	Max Bore Std Hub Mount ◆	Max Bore Protruded Shaft ▲	Cplg Wt No Bore - lb		A		AA		B	BE	C	D	F	H	J		S ▲	Z	Gap	Cover Fasteners ■	
					Nylon Cover	Steel Cover	Nylon Cover	Steel Cover	Nylon Cover	Steel Cover							Nylon Cover	Steel Cover				Size	Allen Wrench Tool
					●	●	●	●	●	●							●	●					
<b>5R</b>	550	4,500	1.625	1.500	2.96	3.26	3.01	3.01	3.17	3.17	2.82	0.77	1.02	2.36	2.520	0.59	0.91	0.91	0.63	0.35	.062	M4	M2.5
<b>10R</b>	1,150	4,500	1.875	1.750	5.47	5.96	3.56	3.56	3.72	3.72	3.61	0.93	1.34	2.83	2.992	0.75	1.10	1.10	0.88	0.43	.062	M4	M2.5
<b>20R</b>	2,800	4,500	2.375	2.250	12.3	13.4	4.96	4.88	5.20	5.12	4.79	1.24	1.77	3.62	4.016	0.98	1.46	1.46	1.00	0.59	.062	M6	M4
<b>30R</b>	4,600	4,500	2.875	2.500	20.7	22.1	5.77	5.63	6.01	5.87	5.97	1.40	2.28	4.13	4.646	1.14	1.65	1.64	1.25	0.67	.062	M6	M4
<b>40R</b>	9,100	3,600	3.375	3.125	37.6	39.9	7.17	6.97	7.48	7.28	7.12	1.84	2.64	5.12	5.906	1.34	2.15	2.09	1.63	0.83	.188	M8	M5
<b>50R</b>	22,200	3,000	4.125	4.125	74.4	78.5	9.09	8.82	9.41	9.13	8.46	2.39	3.03	6.69	7.480	1.81	2.74	2.65	1.75	1.10	.188	M8	M5
<b>60R</b>	35,500	2,500	5.250	5.250	...	137	...	10.51	...	10.94	10.83	2.96	3.94	7.87	8.976	2.37	...	2.64	...	1.39	.188	M10	M6
<b>70R</b>	70,900	2,100	6.125	6.125	...	217	...	12.20	...	12.64	12.76	3.31	4.72	8.94	10.630	2.74	...	2.95	...	1.56	.188	M10	M6
<b>80R</b>	133,000	1,800	7.250	7.250	...	364	...	14.57	...	15.00	14.85	3.82	5.51	10.63	12.913	3.28	...	3.35	...	1.79	.250	M10	M6

★ Standard urethane element operating temperature: -40°C (-40°F) to 95°C (200°F). Dimensions are for reference and are subject to change without notice unless certified.

† Inch/metric conversions may not be direct conversions.

● 5R-50R nylon cover is standard & epoxy coated steel cover is optional. 60R-80R epoxy coated steel cover is standard (nylon cover not available).

■ Cover Fasteners are ISO 7380 Stainless Steel Socket Button Head Cap screws. Two cover fasteners per coupling.

▲ A protruded shaft is defined as the shaft penetrating into the area shown above as Dimension "Z". Size 5R-50R are standard "clearance" fit with keyway and 2 setscrews (one over keyway & one at 90° from keyway). 60R-80R are standard "interference" fit with keyway & no setscrew.

◆ The number of application start/stop cycles should be limited to 10 per hour at the maximum bore condition unless long hubs are utilized. For applications with a Service Factor requirement of 2.0 or more, refer to Falk for possible use of long hubs for additional shaft engagement or utilization of Interference Fits.



# Type R10

## QD Bushings/Dimensions – Inches

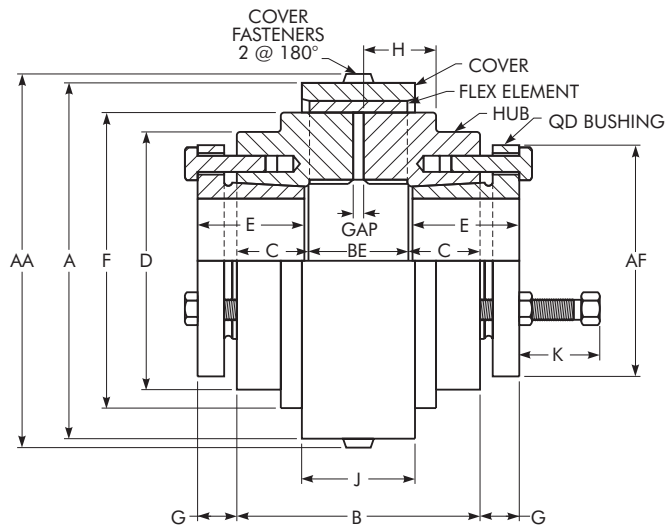

COUPLING SIZE	Bushing Size	Torque Rating	HP per 100 rpm	Max RPM	Max Bore †	Min Bore †	Coupling Weight without Bushing		Gap	BE
		lb-in			Inch	Inch	Nylon Cover – lb	Steel Cover – lb		
5R	JA	550	0.87	4500	1.250	0.500	2.13	2.43	0.063	0.77
10R	JA *	1150	1.82	4500	1.250	0.500	3.49	3.99	0.063	0.93
20R	SD	2800	4.44	4500	1.938	0.500	6.73	7.78	0.063	1.24
30R	SD	4600	7.3	4500	1.938	0.500	10.2	11.6	0.063	1.40
40R	SF	9100	14.4	3600	2.938	0.500	17.0	19.2	0.188	1.84
50R	E *	22200	35.2	3000	3.500	0.875	36.8	40.9	0.188	2.39
60R	J	35500	56.3	2500	4.500	1.438	NA	82.8	0.188	2.96
70R	J *	70900	112.5	2100	4.500	1.438	NA	126	0.188	3.31
80R	M *†	133000	211.0	1800	5.500	1.938	NA	254	0.250	3.82

COUPLING SIZE	Cover Fasteners *		Bushing Fasteners • Inch Hardware	AA – Nylon Cover	AA – Steel Cover	A – Nylon Cover	A – Steel Cover	AF ■	B
	Size	Hex Tool							
5R	M4	M2.5	#10-24 x 1.00	3.17	3.17	3.01	3.01	2.00	2.82
10R	M4	M2.5	#10-24 x 1.00	3.72	3.72	3.56	3.56	2.00	2.98
20R	M6	M4	1/4-20 x 1.00	5.20	5.12	4.96	4.88	3.19	3.76
30R	M6	M4	1/4-20 x 1.00	6.01	5.87	5.77	5.63	3.19	3.92
40R	M8	M5	3/8-16 x 1.25	7.48	7.28	7.17	6.97	4.63	4.52
50R	M8	M5	1/2-13 x 1.75	9.41	9.13	9.09	8.82	6.00	5.70
60R	M10	M6	5/8-11 x 2.50	...	10.94	...	10.51	7.25	9.34
70R	M10	M6	5/8-11 x 2.50	...	12.64	...	12.20	7.25	9.69
80R	M10	M6	3/4-10 x 3.00	...	15.00	...	14.57	9.13	14.22

COUPLING SIZE	C	D	E ■	F	G ■	H	J – Nylon Cover	J – Steel Cover	K – Clearance
	Inch								
5R	1.02	2.36	1.00	2.520	0.44	0.59	0.91	0.91	1.16
10R	1.02	2.83	1.00	2.992	0.44	0.75	1.10	1.10	1.16
20R	1.26	3.62	1.81	4.016	0.56	0.98	1.46	1.46	1.19
30R	1.26	4.13	1.81	4.646	0.56	1.14	1.65	1.64	1.19
40R	1.34	5.12	2.00	5.906	0.84	1.34	2.15	2.09	1.50
50R	1.65	6.69	2.63	7.480	1.13	1.81	2.74	2.65	2.13
60R	3.19	8.03	4.50	8.976	1.50	2.37	...	2.64	2.94
70R	3.19	8.94	4.50	10.630	1.50	2.74	...	2.95	2.94
80R	5.20	10.63	6.75	12.913	1.66	3.28	...	3.35	3.50

★ Refer to specific bushing manufacturer for torque capacity actual ratings.

† 80R requires a special "M" bushing, manufactured for "reverse" mounting. Consult bushing manufacturer.

‡ Typical – refer to bushing manufacturer for exceptions.

• Cover Fasteners are ISO 7380, Stainless Steel, Socket Button Head Cap Screws. Bushing fasteners are SAE Grade 5 (inch) or ISO 8.8 (metric), Hex Head Cap Screws.

■ May vary depending on bushing manufacturer. Consult bushing manufacturer.

## Type R10

## Taper-Lock Bushings/Dimensions – Inches

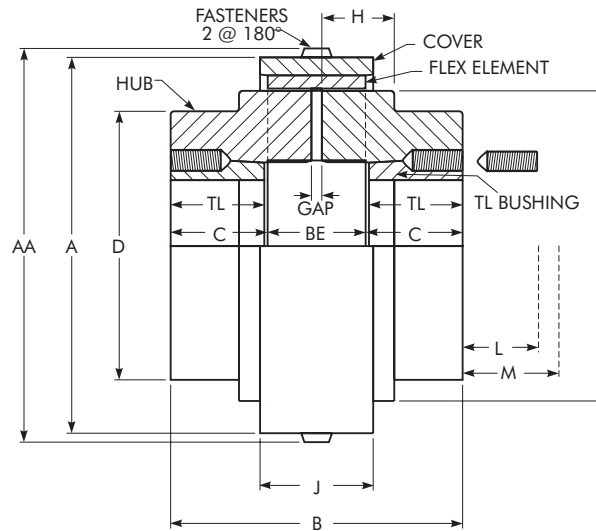

COUPLING SIZE	Bushing Size	Assembly Torque Rating ★ lb-in	HP Per 100 rpm	Max RPM	Max Bore ★ Inch	Min Bore ★ Inch	Coupling Weight w/o Bushing		Gap Inch
							Nylon Cover lb	Steel Cover lb	
5R	1108	550	0.87	4500	1.125	0.500	1.78	2.08	0.063
10R	1210	1,150	1.82	4500	1.250	0.500	3.44	3.93	0.063
20R	1610	2,800	4.44	4500	1.625	0.500	6.86	7.91	0.063
30R	2012	4,600	7.3	4500	2.000	0.500	10.7	12.1	0.063
40R	2517	9,100	14.4	3600	2.500	0.500	19.4	21.7	0.188
50R	3020	22,200	35.2	3000	3.250	0.875	40.9	45.0	0.188
60R	4040	35,500	56.3	2500	4.438	1.438	...	85.9	0.188
70R	4545	70,900	112	2100	4.938	1.938	...	134	0.188
80R	5050	126,000	200	1800	5.313	2.438	...	238	0.250

COUPLING SIZE	Cover Fasteners †		A – Nylon Cover	A – Steel Cover	AA – Nylon Cover	AA – Steel Cover	B	C
	Inch	Size Hex Tool	Inch	Inch	Inch	Inch	Inch	Inch
5R	0.77	M4 M2.5	3.01	3.01	3.17	3.17	2.54	0.89
10R	0.93	M4 M2.5	3.56	3.56	3.72	3.72	3.53	1.30
20R	1.24	M6 M4	4.96	4.88	5.20	5.12	3.84	1.30
30R	1.40	M6 M4	5.77	5.63	6.01	5.87	4.71	1.65
40R	1.84	M8 M5	7.17	6.97	7.48	7.28	5.46	1.81
50R	2.39	M8 M5	9.09	8.82	9.41	9.13	6.72	2.17
60R	2.96	M10 M6	...	10.51	...	10.94	11.07	4.06
70R	3.31	M10 M6	...	12.20	...	12.64	12.37	4.53
80R	3.82	M10 M6	...	14.57	...	15.00	13.90	5.04

COUPLING SIZE	D	F	H	J – Nylon Cover	J – Steel Cover	L ‡		M •		TL Inch
	Inch	Inch	Inch	Inch	Inch	Standard Hex Key	Short ■ Hex Key	Standard Hex Key	Short ■ Hex Key	
5R	2.36	2.520	0.59	0.91	0.91	1.125	0.625	1.250	0.750	0.875
10R	2.83	2.992	0.75	1.10	1.10	1.375	0.813	1.625	1.063	1.000
20R	3.62	4.016	0.98	1.46	1.46	1.375	0.813	1.625	1.063	1.000
30R	4.13	4.646	1.14	1.65	1.64	1.563	0.938	2.000	1.375	1.250
40R	5.12	5.906	1.34	2.15	2.09	1.625	1.000	2.250	1.625	1.750
50R	6.69	7.480	1.81	2.74	2.65	1.813	1.188	2.688	2.063	2.000
60R	7.87	8.976	2.37	...	2.64	2.375	1.625	4.125	3.375	4.000
70R	8.94	10.630	2.74	...	2.95	2.625	1.938	4.750	4.063	4.500
80R	10.63	12.913	3.28	...	3.35	2.813	2.313	5.250	4.813	5.000

★ Typical – refer to bushing manufacturer for exceptions and Service Factor limitations.

† Cover Fasteners are ISO 7380, Stainless Steel, Socket Button Head Cap Screws.

‡ Space required to tighten bushing. Also, space required to loosen screws to permit removal of hub by puller.

• Space required to remove bushing using jackscrews – no puller required.

■ Standard hex key cut to minimum useable length.

# Type R31

## Full Spacer Coupling/Dimensions — Inches

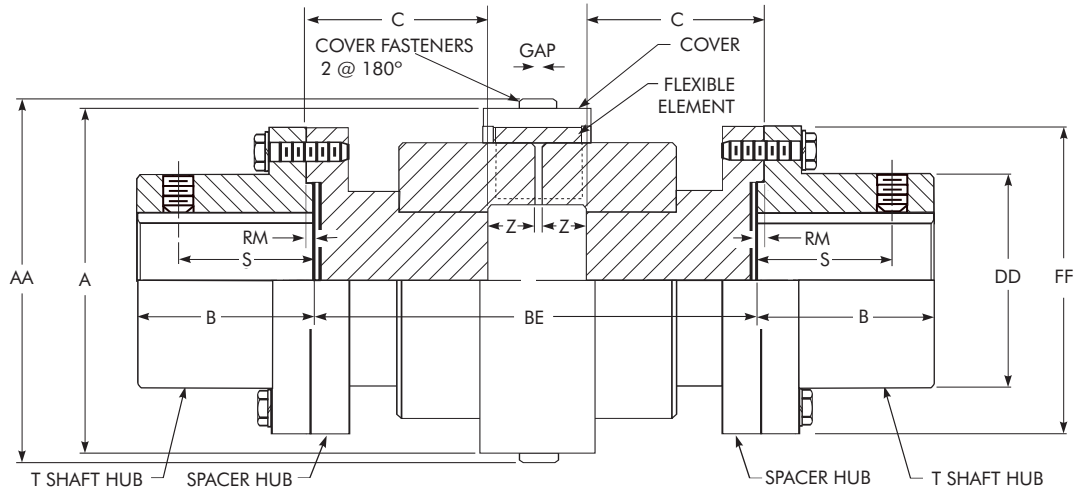

NOTE: Distance Between Shaft Ends (BE) =  $2(C) + 2(Z) + \text{Gap} - 2(RM)$   
 SPACER DIMENSIONS — INCHES

SIZE ★	Torque Rating lb-in	Allow Speed rpm	Max Bore ♦	Cplg Wt No Bore — lb		BE		A		AA		B	DD	FF	RM	S	Z	Gap	Cover Fasteners •		Flange Fasteners ■		T Shaft Hub
				At Min lb	Per Added BE lb/in	Min	Max	Nylon Cover	Steel Cover †	Nylon Cover	Steel Cover †								Size	Allen Wrench Tool	Size	No. Per Flange	
5R	550	4500	1.375	8.0	0.79	3.19	9.25	3.01	3.01	3.17	3.17	1.38	2.06	3.39	0.05	1.080	0.35	0.062	M4	M2.5	M6	4	1020T
10R	1,150	4500	1.625	11.0	0.86	3.50	10.00	3.56	3.56	3.72	3.72	1.63	2.34	3.70	0.05	1.240	0.43	0.062	M4	M2.5	M6	8	1030T
20R	2,800	4500	2.125	21.0	1.49	3.50	10.00	4.96	4.88	5.20	5.12	2.13	3.09	4.45	0.05	1.080	0.59	0.062	M6	M4	M6	8	1040T
30R	4,600	4500	2.375	31.0	1.88	4.38	10.00	5.77	5.63	6.01	5.87	2.38	3.44	4.96	0.05	1.600	0.67	0.062	M6	M4	M8	8	1050T
40R	9,100	3600	3.125	57.0	2.23	5.00	12.25	7.17	6.97	7.48	7.28	3.13	4.31	6.02	0.05	1.840	0.83	0.188	M8	M5	M10	12	1070T
50R	22,200	3000	3.500	100.0	3.31	6.50	12.25	9.09	8.82	9.41	9.13	3.50	4.81	7.01	0.05	1.960	1.10	0.188	M8	M5	M12	12	1080T
60R	35,500	2500	4.000	160.0	4.57	7.87	12.25	...	10.51	...	10.94	4.00	5.63	8.27	0.05	...	1.39	0.188	M10	M6	M16	12	1090T
70R	70,900	2100	4.750	225.0	6.59	8.80	14.70	...	12.20	...	12.64	3.56	6.75	9.88	0.06	...	1.56	0.188	M10	M6	M20	12	1100T
70R	70,900	2100	5.500	265.0	6.59	8.80	14.70	...	12.20	...	12.64	4.10	7.75	10.88	0.06	...	1.56	0.188	M10	M6	M20	12	1110T
80R	133,000	1800	6.250	415.0	8.10	9.85	16.69	...	14.57	...	15.00	4.70	8.88	12.56	0.06	...	1.79	0.250	M10	M6	M24	12	1120T
80R	133,000	1800	7.000	505.0	13.60	10.07	16.69	...	14.57	...	15.00	5.30	9.38	13.63	0.06	...	1.79	0.250	M10	M6	M27	12	1130T

★ Standard urethane element operating temperature: -40°C (-40°F) to 95°C (200°F). Dimensions are for reference only and are subject to change without notice unless certified.)

† 5R-50R nylon cover is standard & epoxy coated steel cover is optional. 60R-80R epoxy coated steel cover is standard (nylon cover not available.)

• Cover Fasteners are ISO 7380 Stainless Steel Socket Button Head Cap Screws. Two cover fasteners per coupling.

■ Flange Fasteners are ISO Grade 10.9 hex head cap screws for 5R-50R and ISO Grade 8.8 hex head cap screws for 60R.

♦ Maximum Inch Bore listed is for a standard square key. Larger bores, with a rectangular key, are available. Sizes 5R-50R are standard clearance fit with setscrew over keyway. Size 60R is standard interference fit with keyway, but no setscrew. For interference fit with setscrew over keyway, refer to 427-105.

TABLE 6 — Taper-Lock® Bushings for T Shaft Hubs

CPLG SIZE	T Shaft Hub	Assembly Torque Rating lb-in	HP per 100 rpm	Allow Speed	Bore Range	Bushings Size
10R	1030T	1,150	1.82	4500	.500-1.125	1108
20R	1040T	2,800	4.44	4500	.500-1.375	1310
30R	1050T	4,300	6.82	4500	.500-1.625	1615
40R	1070T	9,100	14.4	3600	.750-2.500	2525
50R	1080T	11,300	17.9	3000	.750-2.500	2525
60R	1090T	24,000	38.1	2500	.938-3.000	3030
70R	1100T	24,000	38.1	2100	.938-3.000	3030
70R	1110T	44,000	71.1	2100	1.19-3.500	3535
80R	1120T	77,300	122	1800	1.44-4.000	4040
80R	1130T	110,000	174	1800	1.94-4.500	4545

TABLE 7 — Type R31 Standard Spacer Lengths — Inches

CPLG SIZE	BE Lengths (Distance Between Shaft Ends)					
	3.50	4.38	5.00	7.25	9.75	10.00
5R	X	X	X	...	...	...
10R	X	X	X	X	...	...
20R	X	X	X	X	...	...
30R	...	X	X	X	...	...
40R	...	...	X	X	X	...
50R	...	...	...	X	X	X
60R	...	...	...	...	X	...

Other BE lengths available. Refer to Falk.

# Type R35

## Half Spacer Coupling/Dimensions — Inches

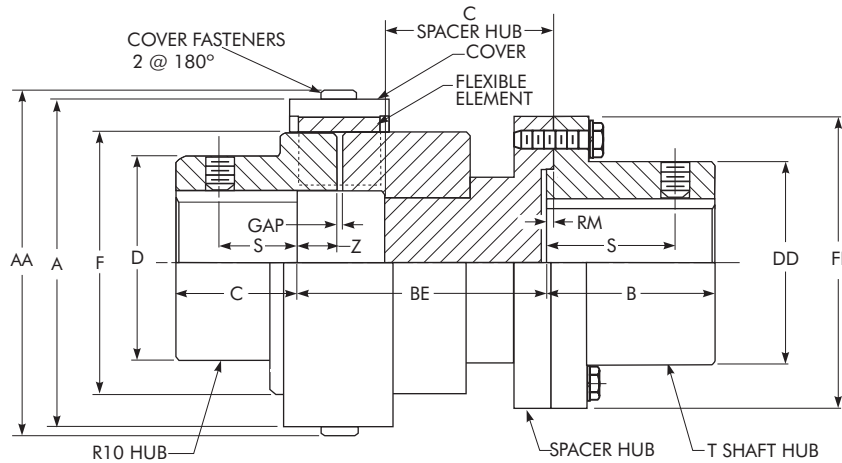

NOTE: Distance Between Shaft Ends (BE) = (C)<sub>Spacer Hub</sub> + 2(Z) + Gap - RM  
 SPACER DIMENSIONS — INCHES

SIZE ★	Torque Rating lb-in	Allow Speed rpm	Max Bore ♦		Cplg Wt No Bore - lb		BE		A		AA		B	C R10 Hub	D	DD	F	FF	RM	S		Z	Gap	Cover Fasteners ●		Flange Fasteners ■		T Shaft Hub
			T Shaft Hub	R10 Hub	At Min BE lb	Per Added BE lb/in	Min	Max	Nylon Cover	Steel Cover †	Nylon Cover	Steel Cover †								Shaft Hub *	R10 Hub *			Size	Allen Wrench Tool	Size	No. Per Flange	
5R	550	4500	1.375	1.625	5.61	0.79	1.99	5.00	3.01	3.01	3.17	3.17	1.38	1.02	2.36	2.06	2.52	3.39	0.05	1.08	0.63	0.35	0.062	M4	M2.5	M6	4	1020T
10R	1,150	4500	1.625	1.875	8.73	0.86	2.35	5.51	3.56	3.56	3.72	3.72	1.63	1.34	2.83	2.34	2.99	3.70	0.05	1.24	0.88	0.43	0.062	M4	M2.5	M6	8	1030T
20R	2,800	4500	2.125	2.375	18.6	1.49	3.01	5.51	4.96	4.88	5.20	5.12	2.13	1.77	3.62	3.09	4.02	4.45	0.05	1.08	1.00	0.59	0.062	M6	M4	M6	8	1040T
30R	4,600	4500	2.375	2.875	28.4	1.88	3.45	5.75	5.77	5.63	6.01	5.87	2.38	2.28	4.13	3.44	4.65	4.96	0.05	1.60	1.25	0.67	0.062	M6	M4	M8	8	1050T
40R	9,100	3600	3.125	3.375	49.4	2.23	3.49	7.25	7.17	6.97	7.48	7.28	3.13	2.64	5.12	4.31	5.91	6.02	0.05	1.84	1.63	0.83	0.188	M8	M5	M10	12	1070T
50R	22,200	3000	3.500	4.125	88.9	3.31	4.45	7.25	9.09	8.82	9.41	9.13	3.50	3.03	6.69	4.81	7.48	7.01	0.05	1.96	1.75	1.10	0.188	M8	M5	M12	12	1080T
60R	35,550	2500	4.000	5.250	148	4.57	5.42	8.00	...	10.51	...	10.94	4.00	3.94	7.87	5.63	8.98	8.27	0.05	...	...	1.39	0.188	M10	M6	M16	12	1090T
70R	70,900	2100	4.750	6.125	220	6.55	6.06	9.01	...	12.20	...	12.64	3.56	4.72	8.94	6.75	10.63	9.88	0.06	...	...	1.56	0.197	M10	M6	M20	12	1100T
70R	70,900	2100	5.510	6.125	240	6.55	6.06	9.01	...	12.20	...	12.64	4.10	4.72	8.94	7.75	10.63	10.88	0.06	...	...	1.56	0.197	M10	M6	M20	12	1110T
80R	133,000	1800	6.250	7.250	390	8.04	6.80	10.22	...	14.57	...	15.00	4.70	5.51	10.63	8.88	12.91	12.56	0.06	...	...	1.79	0.236	M10	M6	M24	12	1120T
80R	133,000	1800	7.000	7.250	425	13.44	6.91	10.22	...	14.57	...	15.00	5.30	5.51	10.63	9.37	12.91	13.62	0.06	...	...	1.79	0.236	M10	M6	M27	12	1130T

★ IMPORTANT: Upon removal of spacer hub, working clearance available for equipment removal = "BE" - "Z".  
 Standard urethane element operating temperature: -40°F (-40°C) to 200°F (95°C). Dimensions are for reference and are subject to change without notice unless certified.  
 † 5R-50R nylon cover is standard & epoxy coated steel cover is optional. 60R-80R epoxy coated steel cover is standard (nylon cover not available).  
 ♦ For R10 hubs see Page 8 for "Max Bore Protuded Shaft" along with the footnote. Maximum Inch Bore listed is for a standard square key. For T shaft hubs only, larger inch bores with a rectangular key are available. Sizes 5R-50R are standard clearance fit with setscrew(s) over keyway. Sizes 60R - 80R are standard interference fit with keyway, but no setscrew. For interference fit with setscrew over keyway, refer to 427-105. For R10 hubs at the Max Bore condition, limit the number of start/stop cycles to 10 per hour unless long hubs are used.  
 \* Standard for T shaft hub is one setscrew over keyway; standard for R10 hub is two setscrews (one over keyway and one at 90° from keyway), Sizes 5-50R.

TABLE 8 — R35 Standard Spacer Lengths

Size	BE	Z	Usable Clearance Gap
5R	2.143	0.35	1.793
	2.362	0.35	2.012
	2.581	0.35	2.231
	2.893	0.35	2.543
	3.500	0.35	3.150
10R	2.004	0.43	1.574
	2.441	0.43	2.011
	2.660	0.43	2.230
	2.973	0.43	2.543
	3.228	0.43	2.798
	3.500	0.43	3.070
	3.937	0.43	3.507
	4.098	0.43	3.668
20R	1.775	0.59	1.185
	2.070	0.59	1.480
	2.510	0.59	1.920
	2.986	0.59	2.396
	3.130	0.59	2.540
	3.386	0.59	2.796
	3.500	0.59	2.910
	3.937	0.59	3.347
	4.255	0.59	3.665

TABLE 8 — R35 Standard Spacer Lengths

Size	BE	Z	Usable Clearance Gap
30R	2.332	0.67	1.662
	2.952	0.67	2.282
	3.464	0.67	2.794
	4.333	0.67	3.663
	5.000	0.67	4.330
40R	3.425	0.83	2.595
	3.681	0.83	2.851
	4.468	0.83	3.638
	4.550	0.83	3.720
	5.000	0.83	4.170
50R	5.800	0.83	4.970
	4.745	1.10	3.645
	4.826	1.10	3.726
	6.076	1.10	4.976
60R	6.201	1.10	5.101
	6.359	1.39	4.969

Other BE lengths available. Refer to Falk.

Taper-Lock bushing for R10 hub, see Page 10.

QD bushing for R10 hub, see Page 9.

Taper-Lock bushing for T shaft hub, see Table 6, Page 11.

# Engineering Data

**TABLE 9 — Recommended Bores for Steel Hubs — Inches**

Shaft Dia	Clearance Fit		Interference Fit		Shaft Dia	Clearance Fit		Interference Fit		Shaft Dia	Clearance Fit		Interference Fit		Shaft Dia	Interference Fit	
	Hub Bore	Clearance	Hub Bore	Interference		Hub Bore	Clearance	Hub Bore	Interference		Hub Bore	Clearance	Hub Bore	Interference		Hub Bore	Interference
<b>+.0000</b> <b>-.0005</b>	<b>+.0010</b> <b>-.0000</b>	<b>.0000</b> <b>.0015</b>	<b>+.0005</b> <b>-.0000</b>	<b>.0000</b> <b>.0010</b>	<b>+.0000</b> <b>-.0010</b>	<b>+.0015</b> <b>-.0000</b>	<b>.0000</b> <b>.0025</b>	<b>+.0010</b> <b>-.0000</b>	<b>.0000</b> <b>.0020</b>	<b>+.0000</b> <b>-.0010</b>	<b>+.0015</b> <b>-.0000</b>	<b>.0000</b> <b>.0025</b>	<b>+.0015</b> <b>-.0000</b>	<b>.0010</b> <b>.0035</b>	<b>+.0000</b> <b>-.0010</b>	<b>+.0015</b> <b>-.0000</b>	<b>.0015</b> <b>.0040</b>
<b>.5000</b>	.5000		.4990		<b>2.2500</b>	2.2500		2.2480		<b>4.0625</b>	4.0625		4.0590		<b>6.7500</b>	6.7460	
<b>.5625</b>	.5625		.5615		<b>3.3125</b>	2.3125		2.3105		<b>4.1250</b>	4.1250		4.1215		<b>7.0000</b>	6.9960	
<b>.6250</b>	.6250		.6240		<b>2.3750</b>	2.3750		2.3730		<b>4.1875</b>	4.1875		4.1840				
<b>.6875</b>	.6875		.6865		<b>2.4375</b>	2.4375		2.4355		<b>4.2500</b>	4.2500		4.2465				
<b>.7500</b>	.7500		.7490		<b>2.5000</b>	2.5000		2.4980		<b>4.3125</b>	4.3125		4.3090		<b>7.2500</b>	7.2450	
<b>.8125</b>	.8125		.8115		<b>2.5625</b>	2.5625		2.5605		<b>4.3750</b>	4.3750		4.3715		<b>7.5000</b>	7.4950	
<b>.8750</b>	.8750		.8740		<b>2.6250</b>	2.6250		2.6230		<b>4.4375</b>	4.4375		4.4340		<b>7.7500</b>	7.7450	
<b>.9375</b>	.9375		.9365		<b>2.6875</b>	2.6875		2.6855		<b>4.5000</b>	4.5000		4.4965		<b>8.0000</b>	7.9950	
<b>1.0000</b>	1.0000		.9990		<b>2.7500</b>	2.7500		2.7480		<b>4.5625</b>	4.5625		4.5590				
<b>1.0625</b>	1.0625		1.0615		<b>2.8125</b>	2.8125		2.8105		<b>4.6250</b>	4.6250		4.6215		<b>8.2500</b>	8.2445	
<b>1.1250</b>	1.1250		1.1240		<b>2.8750</b>	2.8750		2.8730		<b>4.6875</b>	4.6875		4.6840		<b>8.5000</b>	8.4945	
<b>1.1875</b>	1.1875		1.1865		<b>2.9375</b>	2.9375		2.9355		<b>4.7500</b>	4.7500		4.7465		<b>8.7500</b>	8.7445	
<b>1.2500</b>	1.2500		1.2490		<b>3.0000</b>	3.0000		2.9980		<b>4.8125</b>	4.8125		4.8090		<b>9.0000</b>	8.9945	
<b>1.3125</b>	1.3125		1.3115		<b>3.0625</b>	3.0625		3.0600		<b>4.8750</b>	4.8750		4.8715		<b>9.2500</b>	9.2440	
<b>1.3750</b>	1.3750		1.3740		<b>3.1250</b>	3.1250		3.1225		<b>4.9375</b>	4.9375		4.9340		<b>9.5000</b>	9.4940	
<b>1.4375</b>	1.4375		1.4365		<b>3.1875</b>	3.1875		3.1850		<b>5.0000</b>	5.0000		4.9965		<b>9.7500</b>	9.7440	
<b>1.5000</b>	1.5000		1.4990		<b>3.2500</b>	3.2500		3.2475		<b>5.0625</b>	5.0625		5.0585		<b>10.0000</b>	9.9940	
<b>+.0000</b> <b>-.0010</b>	<b>+.0010</b> <b>-.0000</b>	<b>.0000</b> <b>.0020</b>	<b>+.0005</b> <b>-.0000</b>	<b>.0015</b> <b>.0015</b>	<b>3.3125</b>	3.3125		3.3100		<b>5.1250</b>	5.1250		5.1210	<b>.0015</b> <b>.0040</b>	<b>10.2500</b>	10.2435	
<b>1.5625</b>	1.5625		1.5610		<b>3.3750</b>	3.3750		3.3725		<b>5.1875</b>	5.1875		5.1835		<b>10.5000</b>	10.4935	
<b>1.6250</b>	1.6250		1.6235		<b>3.4375</b>	3.4375		3.4350		<b>5.2500</b>	5.2500		5.2460		<b>10.7500</b>	10.7435	
<b>1.6875</b>	1.6875		1.6860		<b>3.5000</b>	3.5000		3.4975		<b>5.3125</b>	5.3125		5.3085		<b>11.0000</b>	10.9935	
<b>1.7500</b>	1.7500		1.7485		<b>3.5625</b>	3.5625		3.5600		<b>5.3750</b>	5.3750		5.3710		<b>11.2500</b>	11.2430	
<b>1.8125</b>	1.8125		1.8110		<b>3.6250</b>	3.6250		3.6225		<b>5.4375</b>	5.4375		5.4335		<b>11.5000</b>	11.4930	
<b>1.8750</b>	1.8750		1.8735		<b>3.6875</b>	3.6875		3.6850		<b>5.5000</b>	5.5000		5.4960		<b>11.7500</b>	11.7430	
<b>1.9375</b>	1.9375		1.9360		<b>3.7500</b>	3.7500		3.7475		<b>5.5625</b>	5.5625		5.5585		<b>12.0000</b>	11.9930	
<b>2.0000</b>	2.0000		1.9985		<b>3.8125</b>	3.8125		3.8100		<b>5.6250</b>	5.6250		5.6210		<b>12.5000</b>	12.4925	
<b>+.0000</b> <b>-.0010</b>	<b>+.0015</b> <b>-.0000</b>	<b>.0000</b> <b>.0025</b>	<b>+.0005</b> <b>-.0000</b>	<b>.0015</b> <b>.0015</b>	<b>3.8750</b>	3.8750		3.8725		<b>5.6875</b>	5.6875		5.6835		<b>13.0000</b>	12.9925	
<b>2.0625</b>	2.0625		2.0610		<b>3.9375</b>	3.9375		3.9350		<b>5.7500</b>	5.7500		5.7460		<b>13.5000</b>	13.4920	
<b>2.1250</b>	2.1250		2.1235		<b>4.0000</b>	4.0000		3.9975		<b>5.8125</b>	5.8125		5.8085		<b>14.0000</b>	13.9920	
<b>2.1875</b>	2.1875		2.1860							<b>5.8750</b>	5.8750		5.8710		<b>14.5000</b>	14.4915	
										<b>5.9375</b>	5.9375		5.9335		<b>15.0000</b>	14.9915	
										<b>6.0000</b>	6.0000		5.9960				
										<b>6.0625</b>	6.0625		6.0585		<b>+.0000</b> <b>-.0010</b>	<b>+.0025</b> <b>-.0000</b>	<b>.0055</b> <b>.0090</b>
										<b>6.1250</b>	6.1250		6.1210		<b>15.5000</b>	15.4910	
										<b>6.1875</b>	6.1875		6.1835		<b>16.0000</b>	15.9910	
										<b>6.2500</b>	6.2500		6.2460		<b>16.5000</b>	16.4905	
										<b>6.3125</b>	6.3125		6.3085		<b>17.0000</b>	16.9905	
										<b>6.3750</b>	6.3750		6.3710				
										<b>6.4375</b>	6.4375		6.4335				
										<b>6.5000</b>	6.5000		6.4960				

\* For shaft diameters larger than 17.000", use an average interference fit of .0005" per inch of shaft diameter within the following bore tolerances:  
 +.0025, -.0000 for over 17" to 20" dia. incl.  
 +.003, -.000 for over 20" to 30" dia. incl.  
 +.004, -.000 for over 30" to 40" dia. incl.  
 Tolerances and fits comply with, or are within, AGMA 9002 standard (Class 1 clearance fit).

**TABLE 10 — Recommended Keyways for Hubs with One Keyway — Inches**

Nominal Bore		Keyway Size ‡ Width x Depth	Width Tolerance †
Over	Thru		
.4375	.5625	.125 x .062	+.0020 -.0000
.5625	.875	.1875 x .094	+.0020 -.0000
.875	1.250	.250 x .125	+.0020 -.0000
1.250	1.375	.3125 x .156	+.0020 -.0000
1.375	1.750	.375 x .188	+.0025 -.0000
1.750	2.250	.500 x .250	+.0025 -.0000
2.250	2.750	.625 x .312	+.0030 -.0000
2.750	3.250	.750 x .375	+.0030 -.0000
3.250	3.750	.875 x .438	+.0030 -.0000
3.750	4.500	1.000 x .500	+.0030 -.0000
4.500	5.500	1.250 x .625	+.0035 -.0000
5.500	6.500	1.500 x .750	+.0035 -.0000
6.500	7.500	1.750 x .750	+.0040 -.0000
7.500	9.000	2.000 x .750	+.0040 -.0000
9.000	11.000	2.500 x .875	+.0045 -.0000
11.000	13.000	3.000 x 1.000	+.0045 -.0000
13.000	15.000	3.500 x 1.250	+.0050 -.0000
15.000	18.000	4.000 x 1.500	+.0050 -.0000

‡ One square key for bore diameters thru 6.500"; one rectangular key for bore diameters over 6.500".

† Depth tolerance: +.010" to +.020".

# Engineering Data

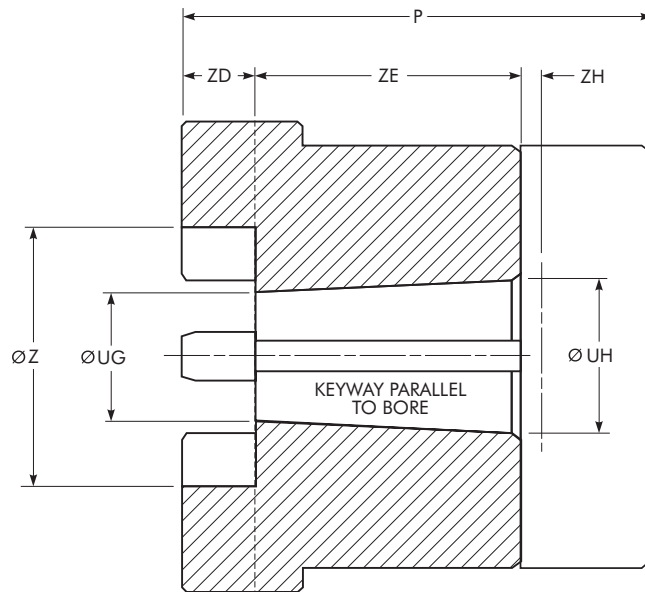

**TABLE 11 — Standard AISE AC & DC Mill Motor Coupling Selections**

Motor Frame Sizes			Coupling Size	Torque Rating (lb-in)	Ø UG	Ø UH	Ø Z	Keyway	ZD	ZE	ZH +.000 -.000
2, 602	802 A,B,C	AC 1, 2, 4	40R † 50R	9,100 22,200	1.438	1.750	3.181 4.173	.500 x .250 .500 x .250	0.83 1.10	3.00	.024
603, 604	803, 804	...	50R 60R	22,200 35,500	1.635	2.000	4.173 5.315	.500 x .250 .500 x .250	1.10 1.39	3.50	.029
606	806	AC 8, 12	50R † 60R 70R	22,200 35,550 70,900	2.083	2.500	4.173 5.315 6.299	.500 x .250 .500 x .250 .500 x .250	1.10 1.39 1.56	4.00	.029
608	808	...	60R 70R 80R	35,550 70,900 133,000	2.531	3.000	5.315 6.299 7.480	.750 x .250 .750 x .250 .750 x .250	1.39 1.56 1.79	4.50	.029
610	810	AC 18	70R 80R	70,900 133,000	2.781	3.250	6.299 7.480	.750 x .250 .750 x .250	1.56 1.79	4.50	.034
612	812	AC 25, 30	70R 80R	70,900 133,000	3.104	3.625	6.299 7.480	.750 x .250 .750 x .250	1.56 1.79	5.00	.034
614	814	AC 40, 50	80R	133,000	3.729	4.250	7.480	1.000 x .375	1.79	5.00	.034

† Must use "standard" socket on mill motor nut. "Impact" socket will not fit.

**TABLE 12 — Taper & Counter Bore Limitations**

Coupling Size	P Max	Ø UG Min	Ø UH Max	Ø Z Max	ZD Max	ZE Min	Keyway *
5R	2.40	.500	1.500	1.535	.362	.827	.375 x .188
10R	3.11	.500	1.750	1.811	.441	1.000	.375 x .188
20R	4.13	.750	2.250	2.311	.598	1.063	.500 x .250
30R	5.24	1.000	2.500	2.559	.677	1.339	.625 x .313
40R	6.10	1.125	3.125	3.181	.835	1.339	.750 x .375
50R	7.17	1.125	4.125	4.173	1.110	1.811	1.000 x .500
60R	7.29	1.250	5.250	5.315	1.394	2.126	1.250 x .625
70R	8.65	1.500	6.125	6.299	1.571	2.244	1.500 x .750
80R	10.06	1.500	7.250	7.480	1.795	2.618	1.750 x .875

\* Keyway shown is for maximum bore with square key.

**TABLE 13 — Type R10 Mill Motor Hubs**

Mill Motor Frame Size			R10 Flex Hubs								
			5R	10R	20R	30R	40R	50R	60R	70R	80R
602	802 A, B, C	AC 1, 2 & 4	...	...	...	...	X	X	...	...	...
603 604	803 804		...	...	...	...	Consult Falk	X	X	...	...
606	806	AC 8 & 12	...	...	...	...	...	X	X	X	...
608	808		...	...	...	...	...	...	X	X	X
610	810	AC 18	...	...	...	...	...	...	Consult Falk	X	X
612	812	AC 25 & 50	...	...	...	...	...	...	...	X	X
614	814	AC 40 & 50	...	...	...	...	...	...	...	X	X

# Engineering Data

**TABLE 14 — Operating Misalignment Capacity**

COUPLING SIZE	Parallel Offset (Inch)	Angular (Degrees)
5R	.04	1°
10R	.08	1°
20R	.08	1°
30R	.08	1°
40R	.12	1°
50R	.12	1°
60R	.12	1°
70R	.12	1°
80R	.12	1°

**TABLE 15 — Mass and WR2**

R10 Mass						
COUPLING SIZE	Element	Nylon Cover	Steel Cover	R10 Hub (No Bore)	Total w/Nylon Cover	Total w/Steel Cover
	lb	lb	lb	lb	lb	lb
5R	0.0736	0.0700	0.370	1.41	2.96	3.26
10R	0.132	0.100	0.590	2.62	5.46	5.96
20R	0.408	0.240	1.29	5.84	12.3	13.4
30R	0.626	0.370	1.82	9.83	20.7	22.1
40R	1.30	0.860	3.13	17.7	37.6	39.9
50R	2.70	1.70	5.83	35.0	74.4	78.5
60R	4.08	NA	7.29	63.1	NA	137
70R	6.17	NA	10.2	100	NA	217
80R	10.2	NA	14.6	169	NA	364

R10 WR <sup>2</sup>						
COUPLING SIZE	Element	Nylon Cover	Steel Cover	R10 Hub (No Bore)	Total w/Nylon Cover	Total w/Steel Cover
	lb-in <sup>2</sup>	lb-in <sup>2</sup>	lb-in <sup>2</sup>	lb-in <sup>2</sup>	lb-in <sup>2</sup>	lb-in <sup>2</sup>
5R	0.0907	0.14	0.76	1.05	2.33	2.95
10R	0.2291	0.30	1.7	2.79	6.10	7.50
20R	1.348	1.3	7.0	10.5	23.7	29.4
30R	2.747	2.8	13.2	23.2	51.9	62.3
40R	8.843	10.06	35.3	65.4	150	175
50R	30.4	31.82	106	218	499	573
60R	67.8	NA	188	557	NA	1370
70R	141	NA	358	1189	NA	2877
80R	334	NA	740	2939	NA	6952

R31/R35 WR <sup>2</sup> Values ★									
SIZE	T31 Shaft Hub	R31 Assembly †				R35 Assembly ‡			
		Min BE (inch)	WR <sup>2</sup> at Min BE (lb-in <sup>2</sup> )		WR <sup>2</sup> (lb-in <sup>2</sup> ) per Inch	Min BE (inch)	WR <sup>2</sup> at Min BE (lb-in <sup>2</sup> )		WR <sup>2</sup> (lb-in <sup>2</sup> ) per Inch
			Nylon Cover	Steel Cover			Nylon Cover	Steel Cover	
5R	1020	3.19	7.53	8.15	0.351	1.99	4.93	5.55	0.351
10R	1030	3.50	13.6	15.0	0.413	2.35	9.58	11.0	0.413
20R	1040	3.50	39.1	44.8	1.253	3.01	32.6	38.3	1.253
30R	1050	4.38	71.8	82.2	1.980	3.45	65.3	75.7	1.980
40R	1070	5.00	217	243	4.164	3.49	184	209	4.164
50R	1080	6.50	579	654	10.78	4.45	539	613	10.78
60R	1090	7.87	N.A.	1459	20.35	5.42	N.A.	1415	20.35
60R	1100	9.60	N.A.	2050	23.79	6.28	N.A.	1710	23.79
70R	1100	8.80	N.A.	2967	40.58	6.06	N.A.	2922	40.58
70R	1110	8.80	N.A.	3617	40.58	6.06	N.A.	3247	40.58
80R	1120	9.78	N.A.	7669	61.97	6.80	N.A.	7214	61.97
80R	1130	10.00	N.A.	9611	144.83	6.91	N.A.	8185	144.83

★ WR<sup>2</sup> values are based on hubs with no bore.

† For R31 Mass, refer to Page 11.

‡ For R35 Mass, refer to Page 12.

Find out more about **FALK®**

falkcorp.com

or CALL

## THE FALK CORPORATION

### Plant Locations

#### Main

P.O. Box 492 Zip 53201-0492  
3001 W. Canal Street  
Zip 53208-4200

Milwaukee, WI USA  
Phone: 1-800-852-FALK (3255) or  
414-342-3131  
FAX: 414-937-4359  
E-mail: falkinfo@falkcorp.com  
Internet: www.falkcorp.com

Falk Capitol Drive  
12001 West Capitol Drive  
Milwaukee, WI 53222-1003  
414-438-3031  
FAX: 414-438-3049

Falk Auburn  
1600 Pumphrey Ave.  
Auburn, AL 36832  
334-321-9120  
FAX: 334-821-9103

Falk Renew  
1903 South Moorland Blvd  
New Berlin, WI 53151  
262-317-1420  
FAX: 262-317-1428

Falk Australia Pty.  
34-36 Broadmeadow Rd  
Broadmeadow, NSW 2294  
61-2-4962-8000  
FAX: 61-2-4962-8001

### Global Sales Offices

#### United States

Atlanta, GA  
334-728-0747

Baltimore, MD  
717-993-0601

Birmingham, AL  
205-661-3933

Charleston, WV  
304-595-1394

Charlotte, NC  
704-531-9250

Chicago, IL  
847-677-6492

Cincinnati, OH  
513-563-9699

Cleveland, OH  
330-528-1557

Dallas, TX  
469-556-7313

Denver, CO  
303-980-5131

Detroit, MI  
248-969-2553

Houston, TX  
281-477-9570

Kansas City, KS  
913-685-3254

Memphis, TN  
901-309-0340

Miami, FL  
954-436-6055

Milwaukee, WI  
262-646-4346

Minneapolis, MN  
763-522-0994

New Orleans, LA  
504-832-1448

Northeast  
860-355-0478

Northwest  
360-546-3411

Omaha, NE  
402-896-4520

Phoenix, AZ  
480-460-7188

Pittsburgh, PA  
412-563-1754

Rochester, NY  
585-223-5205

St. Louis, MO  
636-256-7600

Salt Lake City, UT  
801-268-4419

Tampa, FL  
941-358-1045

Victorville, CA  
760-401-0749

### Canada

Calgary, AB  
403-225-6630

Montreal, PQ  
450-424-7100

Toronto, ON  
416-674-0346

Vancouver, BC  
604-946-8506

### Latin America

Mexico, D.F.  
52-5-333-2500

Santiago, Chile  
56-2-231-5647

Sao Paulo, Brazil  
55-11-882-1000

### Europe

Brighouse, United Kingdom  
44-1484-401872

### Asia/Pacific

Korea  
82-42-603-5644

Newcastle, Australia  
61-2-4962-8000

Perth, Australia  
61-8-9414-7800

Shanghai, China  
86-21-6219-6847

Singapore  
65-444-0388

Taiwan  
886-7-556-0263

### South Africa

Gauteng, SA  
27-11-422-2496

### Distribution Centers

Auburn, AL  
PH 334-821-9100  
FAX 414-937-4003

Doncaster, United Kingdom  
PH 44-1484-401872  
FAX 44-1484-401341

Milwaukee, WI  
PH 414-342-3131  
FAX 414-937-4359

Sacramento, CA  
PH 877-937-6744  
FAX 414-937-4444

Toronto, ON  
PH 416-675-6071  
FAX 416-213-1020